

MODULAR ELECTRONIC DEVICES



ELKO EP, Holding

The company ELKO EP has been one of the leading European players in the field of residential and industrial electrical devices for more than 24 years. Since 2007, the company has been developing and producing its own system of Smart Home & Building Solutions called iNELS.

At present, ELKO EP employs nearly 240 people, exports to 70 countries around the world and already has 13 foreign branches. The company is justly proud to produce its own components, and to have its own development and innovation of new products. It is also able to offer its customers instantaneous distribution and rapid, flawless service. The company became the Company of the Year in 2012 and earned its place as one of the TOP 100 Czech companies.



Facts and Stats



2nd position
in Europe

13
BRANCHES
OVER THE WORLD

70
EXPORTING
COUNTRIES

240
EMPLOYEES

5 000
iNELS INSTALLATION

12 000 000
MANUFACTURED PRODUCTS

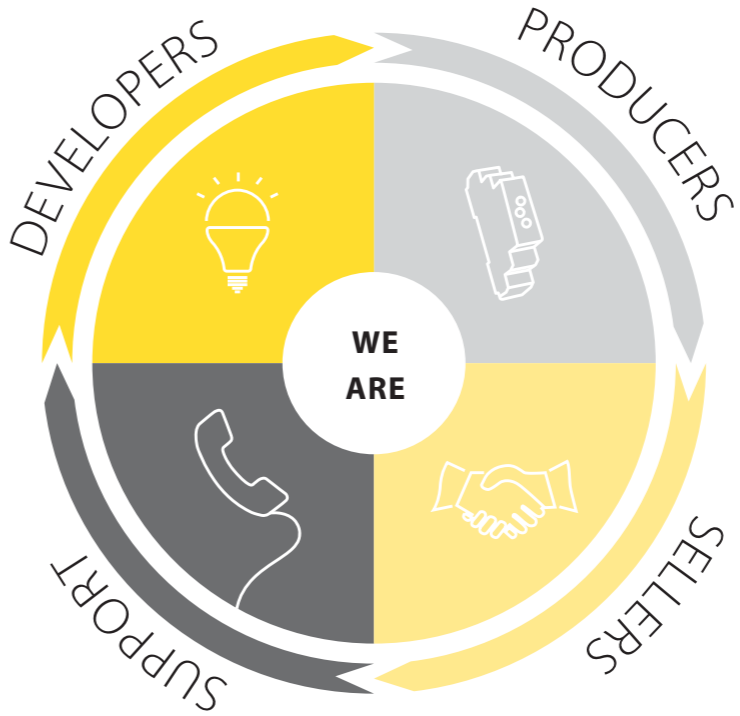

Product Lines ELKO EP



RELAYS - Modular electronic devices

A wide range of electronic modular devices, which bring new possibilities to home and office control, monitoring and security, as well as to industrial process control: time relays, installation contactors, staircase automatic switches, time switches clocks, dimmers, thermostats, power supplies units, control and signalling devices, GSM gates, etc.



iNELS RF Control - Wireless control

A unique wireless control system providing you perfect control over your home! The RF Control system enables you to control functions such as heating, lighting, electrical appliances and window shutters, all with a single touch. No wall cutting, fast and easy installation, exclusive design of wireless wall switch buttons and other components.



Smart home kits

Smart kit is a starter kit for Smart Home or House with intelligent electro-installation. After Smartphones and Smart TV, Smart house is the next step in the development of modern technology and housing.



iNELS BUS SYSTEM - Intelligent electro-installation system

iNELS will transform your house into a timeless intelligent household. It will take charge of heating and air-conditioning, regulation, lighting control and home appliance switching, while also providing perfect security for your home. Enjoy controlling your entire house via a TV screen thanks to iNELS Multimedia (iMM) or use the App for your smartphone or tablet.



Measuring energy

Measuring and visualization of consumption of energy (electricity, water, gas) for existing buildings, where meters are already installed. Sensing takes place without interference with the meters and data is transferred wirelessly. Displayed in a smartphone application or in a computer from the Cloud.



AUDIO/VIDEO

In this group you can find products, which brings you a new dimension of controlling music, video and home appliances. These are not just ordinary controllers but products which can be a perfect part of your electro-installation.



LOGUS⁹⁰ - Home switches and sockets

We offer you exclusive switches, sockets and accessories in a standard plastic or metallic design. However, there are also charming luxury frames from purely natural materials such as genuine wood, metal, granite or hardened glass. Be especial!



ELKO Lighting s.r.o.

We don't only supply LED light sources to the market, but also we bring a complex lighting solution. Our goal is to supply quality and affordable LED light sources and provide a high-level of service - always to satisfy our customers!



ONE FOR ALL!



ONE TIME RELAY FROM ELKO EP COMPANY

CAN REPLACE UP TO 10 OTHERS TYPES

10

Reasons, why our relays are among world's best-selling relays

- 1 Universal power supply 12-240 AC/DC
- 2 Time range from 0,1 s till 10 days
- 3 10 frequently-used functions
- 4 Made from high-quality parts and components
- 5 Contact current rating - 16 A
- 6 Up to 3 x changeover contacts in one module
- 7 Warranty - 5 years
- 8 Certification which meets requirements of the World standards (UL, CE, PT,...)
- 9 More than 22 years of experience what guarantees top quality
- 10 Double vendor inspection

Modular electronic devices

Time relays	
CRM-81J, CRM-83J Single-function time relay	10
CRM-82TO Delay OFF without supply voltage	11
SJR-2 Doublestage delay unit	12
CRM-2T Delay ON star/delta	13
CRM-2H Asymmetric cycler	14
CRM-61 Multifunction time relays	15
CRM-91H, CRM-93H, CRM-95 Multifunction time relays	16
CRM-91HE, CRM-2HE Time relay with external potentiometer	18
PRM-91H/8, PRM-91H/11, PRM-92H, PRM-2H Plug-in time relay	19
PDR-2/A, PDR-2/B Programmable digital relay	20
SHT-1, SHT-1/2, SHT-3, SHT-3/2 Digital time switch clock	22
SHT-4 Digital time switch with an astronomical program	23
SHT-6 Time switch with DCF control	24
DCFR-1 Receiver DCF 77	25
SMR-K, SMR-T, SMR-H, SMR-B Super-multifunction relay	26
CRM-42, CRM-42F Programmable staircase switch with signalling before switch off	28
CRM-4 Staircase switch	30
Auxiliary and Power relays	
VS116B/230, VS116K, VS116U, VS308K, VS308U, VS316/24, VS316/230 Power relays	32
750L, 782L Power relays plug-in	34
Dimmers	
DIM-2 Staircase switch with dimming	39
DIM-5 Controlled dimmer	40
DIM-14 Controlled dimmer	41
DIM-6 Controlled dimmer	42
DIM6-3M-P Expanding power module	43
DIM-15, SMR-M Universal dimmer	44
SMR-S, SMR-U Controlled dimmer	46
LIC-1 Lighting intensity controller	47
LIC-2 Lighting intensity controller	48
DCDA-33M LED Dimmer DALI/DMX	49
Power supplies	
PSB-10-12, PSB-10-24, PS-10-12, PS-10-24, PS-30-12, PS-30-24, PS-30-R, PS-100-12, PS-100-24 Power supplies	52
DR-60-12, DR-60-24 Power supplies	54
ZSR-30, ZNP-10 Power supply	55
ZTR-8-8, ZTR-8-12, ZTR-15-12 Bell transformers	56
Twilight switches	
SOU-1 Twilight switch	59
SOU-2 Twilight switch with digital time switch clock	60
SOU-3 Twilight light switch	61
Memory relays	
MR-41, MR-42 Memory & latching relays	62
Control and signalling devices	
USS Controlling and signalling modules	63
Monitoring relays	
HRN-33, HRN-63 HRN-34, HRN-64, HRN-35, HRN-37, HRN-67 Monitoring voltage relay	68
HRN-41, HRN-42 Monitoring voltage relay	70
HRN-55, HRN-55N Relay for monitoring phase sequence and failure	71
HRN-57, HRN-57N Relay for monitoring over/under voltage in 3-phase mains	72
HRN-54, HRN-54N Relay for monitoring over/under voltage, phase sequence and failure	73

HRN-43, HRN-43N Relay for complete monitoring 3-phase mains	74
HRN-56 Relay for monitoring phase sequence and failure	76
MPS-1 Optical signaling of three-phase main	77
HRF-10 Frequency monitoring relay	78
COS-1 Power factor monitoring relay	79
PRI-32 Current monitoring relay	80
PRI-51 Current monitoring relay	81
PRI-52 Current monitoring relay	82
PRI-53 Three-phase current monitoring relay	83
PRI-41, PRI-42 Current monitoring relay	84
HRH-5 Level switch	85
HRH-1 Level switch	86
HRH-6 Level switch	88
HRH-7 Level switch	90
HRH-x Level sets	92
HRH-4 Level set	94
Level switches accessories	
SHR Level sensors	95
Cables, wires	96
Thermostats and hygrostats	
TER-3A, TER-3B, TER-3C, TER-3D, TER-3G, TER-3H Thermostats	99
TER-3E, TER-3F Thermostats	100
TER-4 2-stage thermostat	101
TER-9 Multifunction digital thermostat	102
TER-7 Thermostat for monitoring temperature of motor winding	104
ATR, ATF, ATC Analog room and floor thermostat	105
DTR, DTF, DTC Digital room and floor thermostat	106
ATV-1 Energy-saving digital thermo-valve	107
TEV-1 Thermostat	108
TEV-2, TEV-3 Thermostats	109
TEV-4 Thermostat	110
RHT-1 Hygro-thermostat	111
RHV-1 Hygrostat	112
Accessories to Thermostats	
TC, TZ, Pt100 Temperature sensors	113
Telva 230 V, Telva 24V Thermo drive	114
LKM-45 Installation box	114
Installation contactors	
VS120, VS220, VS420, VS425, VS440, VS463 Installation contactors	116
VSM220, VSM425 Installation contactors with manual control	118
Technical information	
Main instructions for correct use of ELKO EP products	122
Product loadability	123
Electromagnetic compatibility of ELKO EP, s.r.o. products	125
EMC - parameters	126
Overview of tested types of light sources and the loads	127
Products packing	128
Dimensions	129
Examples of usage	136
Support of project design	145

Single-function

CRM-81J
3 functions and 6 time ranges, multivoltage or 230 V supply, output 16 A changeover/SPDT.

CRM-83J
as CRM-81J but with 3x8 A changeover output/SPDT.

CRM-82TO
"true OFF" relay - delay off without supply, for back-up circuits.

SJR-2
two-state delay unit (2x delay on), gradual switching of high loads.

CRM-2T
delay start-up of motors star/delta.

CRM-2H
asymmetric cyclers, independent time setting ON/OFF.

CRM-2HE
as CRM-2H, but time setting by external potentiometers (for frequent setting).

Multifunction

Analog

CRM-91H
10 functions, 10 time ranges, 1x output 16 A changeover/SPDT, multivoltage or 230 V supply.

CRM-93H
as CRM-91 but output 3x 8 A changeover/SPDT.

CRM-9S
as CRM-91 but contactless output (triac 0.7A).

CRM-61
cost effective version of CRM-91H, 6 functions, 6 time ranges. Output 8 A changeover/SPDT, supply AC 24-240 V, DC 24V.

CRM-91HE
as CRM-91H but with time setting by external potentiometer (for frequent setting).

Potentiometer
potentiometer - external control unit for CRM-91HE and CRM-2HE, mounting into a switchboard, max connection length 10 m.

Digital

PDR-2A
4 digit display, 16 functions, 2 independent times 0.01s-100 hrs, 2 outputs 16 A changeover/SPDT START/STOP inputs.

PDR-2B
as PDR-2A but 10 functions for each output and time - meaning two relays in one device.

SHT-1, SHT-1/2
SHT-1: time switch with daily, weekly programming. 1-channel, output 16 A changeover/SPDT. SHT-1/2: as SHT-1, but 2-channel.

SHT-3, SHT-3/2
as SHT-1 but with daily, weekly, monthly, and annual programming up to 2095. SHT-3/2: as SHT-3, but 2-channel.

SHT-4
Timer with an astronomical program to control the lighting without using a light sensor. 2-channel.

SHT-6
Time switch with DCF managing. Daily, weekly and annual program, output 16 A. 1-channel.

PLUG-IN

PRM-91H/11
as CRM-91H but into 11-pin socket, multivoltage supply, output contact 16 A.

PRM-91H/8
as PRM-91H/11 but with 8-pin socket, output contact 16 A.

PRM-92H
as PRM-91H but with 2x changeover / SPDT 8 A contacts, into 11-pin socket.

PRM-2H
as CRM-2H but with 11-pin socket, 2x changeover, 8 A contact.

socket to DIN rail
ES-11 (11 pin)
ES-8 (8 pin).

MINI

SMR-K
super multifunction relay for installation into an installation box, 3 wire connection (without neutral). Input: can be connected in parallel with LED energy saving light bulb or fluorescent lamp.

SMR-T
super multifunction relay for installation into a wiring box, 3 wire connection (without neutral).

SMR-H
as SMR-T but 4 wire connection, output - triac 0-200 VA, 9 functions including function of memory relay.

SMR-B
as SMR-H but output relay contact 16 A (possibility to switch also fluorescent lights).

Staircase switch

CRM-4
basic version, time 0.5-10 min, output contact 16 A, anti-blocking function.

CRM-42
programmable staircase switch with warning before switching off, time setting by number of button pressings.

CRM-42F
programmable staircase switch without warning before switching off, time setting by number of button pressings.

DIM-2
with dimming, setting: dim-up/shining/dim-down brightness only for el. bulbs output up to 500 VA.

Chart 1. Version
DIN rail mounting

Type	Type																													
	CRM-81J/ZR	CRM-81J/ZN	CRM-81J/BL	CRM-83J/ZR	CRM-83J/ZN	CRM-83J/BL	CRM-82TO	CRM-91H	CRM-93H	CRM-91HE	CRM-2HE	CRM-9S	CRM-2H	CRM-2T	CRM-4	CRM-42(CRM-42F)	CRM-61	SJR-2	PDR-2/A	PDR-2/B	SHT-1 (SHT-1/2)	SHT-3 (3/2), SHT-6	SHT-4	SOU-2	PRM-91H	PRM-92H	PRM-2H			
Design	1-MODULE	•	•	•	•	•	•	•	•	•	•	•	•	•	•	•	•	•	•	•	•	•	•	•	•	•	•	•	•	
	2-MODULE																													
	3-MODULE																													
	pLUG-IN																													
Adjusting	Under the switch	See chart 2 Version - mounting into an installation box																												
	Rotary switch	•	•	•	•	•	•	•	•	•	•	•	•	•	•	•	•	•	•	•	•	•	•	•	•	•	•	•	•	
	Button																													
Functions	Sliding switch																													
	External potentiometer																													
	Delay OFF after switch off the Input supply																													
	Delay ON	•			•			•	•	•	•																			
	Delay OFF	•			•			•	•	•	•																			
	Symmetrical cyclers starting with delay																													
	Delay OFF after impulse OFF				•			•	•	•	•																			
	Symmetrical cyclers starting with impulse																													
	Staircase switch																													
	Impulse shift																													
	Memory (impulse) relay																													
	Impulse generator																													
	Delay ON at switch on controlling cyclers																													
	Asymmetric cyclers starting with delay																													
Asymmetric cyclers starting with impulse																														
Delay ON star / delta																														
Switching in real time																														
Impuls relay in delay ON																														
Time	0.1 - 1 s	•	•	•	•	•	•	•	•	•	•	•	•	•	•	•	•	•	•	•	•	•	•	•	•	•	•	•	•	
	1 - 10 s	•	•	•	•	•	•	•	•	•	•	•	•	•	•	•	•	•	•	•	•	•	•	•	•	•	•	•	•	
	1 - 10 min	•	•	•	•	•	•	•	•	•	•	•	•	•	•	•	•	•	•	•	•	•	•	•	•	•	•	•	•	
	0.1 - 1 hrs	•	•	•	•	•	•	•	•	•	•	•	•	•	•	•	•	•	•	•	•	•	•	•	•	•	•	•	•	
	1 - 10 hrs	•	•	•	•	•	•	•	•	•	•	•	•	•	•	•	•	•	•	•	•	•	•	•	•	•	•	•	•	
	0.1 - 1 day																													
	1 - 10 days																													
	3 - 30 days																													
	10 - 100 days																													
	30 s - 10 min																													
	99 h 59 min 59 s																													
	Day																													
	Week																													
	Month																													
Year																														
Supply voltage	230 V AC	•	•	•	•	•	•	•	•	•	•	•	•	•	•	•	•	•	•	•	•	•	•	•	•	•	•	•	•	
	12 - 240 V AC/DC	•	•	•	•	•	•	•	•	•	•	•	•	•	•	•	•	•	•	•	•	•	•	•	•	•	•	•	•	
	12 - 240 V AC																													
	1x changeover / SPDT 8 A																													
	1x changeover / SPDT 16 A	•	•	•																										
	2x changeover / DPDT 8 A																													
Output	2x changeover / DPDT 16 A																													
	3x changeover / SPDT 8 A																													
	Static output (triac)																													
	1x NO 16 A																													

Chart 2. Version

Mounting into an installation box

Type	SMR-K, SMR-T,	SMR-H	SMR-B	
	a - delay off on entering edge	•		•
b - delay off on downward edge	•		•	
c - delay off on downward edge	•		•	
d - cyclers - flasher by impuls	•		•	
e - pulse shift	•		•	
f - delay on	•		•	
g - pulse relay	•		•	
h - impulse relay with delay	•		•	
i - cyclers starting with gap	•		•	
j - delay on after switched off			•	
Time	0.1 - 1 s	•		•
	1 - 10 s	•		•
	0.1 - 1 min	•		•
	1 - 10 min	•		•
	0.1 - 1 h	•		•
	1 - 10 h	•		•
Number of contacts	0.1 - 1 day	•		•
	1 - 10 days	•		•
	Supply voltage	AC 230 V	•	•
Number of contacts	1x triac	•		
	1x NO AgSnO ₂			•



EAN code
CRM-81J according to type
CRM-83J according to type

Technical parameters	CRM-81J	CRM-83J
Functions:	ZR - delay ON / ZN - delay OFF / BL - cycler 1:1	
Supply terminals:	A1 - A2	
Voltage range:	AC/DC 12 - 240 V (AC 50 - 60 Hz)	
Burden:	AC 0.7 - 3 VA / DC 0.5 - 1.7 W	
Voltage range:	AC 230 V / 50 - 60 Hz	
Consumption (apparent/loss):	AC max. 12 VA / 1.3 W	AC max. 12 VA / 1.9 W
Supply voltage tolerance:	-15 %; +10 %	
Supply indication:	green LED	
Time ranges:	0.1 s - 10 h (in 6 ranges)	
Time setting:	potentiometer	
Time deviation:	5 % - mechanical setting	
Repeat accuracy:	0.2 % - set value stability	
Temperature coefficient:	0.01% / °C, at =20 °C (0.01 % / °F, at = 68°F)	
Output		
Number of contacts:	1x chang./ SPDT (AgNi / Silver Alloy)	3x chang./ 3PDT (AgNi / Silver Alloy)
Current rating:	16 A / AC1	8 A / AC1
Breaking capacity:	4000 VA / AC1, 384 W / DC	2000 VA / AC1, 192 W / DC
Inrush current:	30 A / <3 s	10 A / <3 s
Switching voltage:	250 V AC1 / 24 V DC	
Min. breaking capacity DC:	500 mW	
Output indication:	red LED	
Mechanical life:	3x10 ⁷	
Electrical life (AC1):	0.7x10 ⁵	
Control		
Consumption of input:	AC 0.025 - 0.2 VA / DC 0.1 - 0.7 W (UNI), AC 0.53 VA (AC 230 V)	
Load between S-A2:	Yes	
Control terminals:	A1-S	
Glow tubes connections:	230 V - Yes / UNI - No	
Max. amount of glow lamps connected to controlling input:	UNI - glow lamps cannot be connected 230 V - max. 10 pcs (measured with glow lamp 0.68 mA / 230 AC)	
Impulse length:	min. 25 ms / max. unlimited	
Reset time:	max. 150 ms	
Other information		
Power of control input:	-20 °C to +55 °C (-4 °F to 131 °F)	
Storage temperature:	-30 °C to +70 °C (-22 °F to 158 °F)	
Electrical strength:	4 kV (supply-output)	
Operating position:	any	
Mounting:	DIN rail EN 60715	
Protection degree:	IP 40 from front panel / IP 20 terminals	
Overvoltage category:	III.	
Pollution degree:	2	
Max. cable size(mm ²):	solid wire max. 1x2.5 or 2x1.5 / with sleeve max. 1x2.5 (AWG 12)	
Dimensions:	90 x 17.6 x 64 mm (3.5" x 0.7" x 2.5")	
Weight:	(UNI) 62g (2.2 oz.), (230) 60g (2.1 oz.) (UNI) 86g (3 oz.), (230) 82g (2.89 oz.)	
Standards:	EN 61812-1, EN 61010-1	

- Single-function and single-time relay with fine time setting by a potentiometer (within the frames of a particular time range).
- Suitable for applications where function and time requirements are known.
- Time switch, possible to be used for pump delay after switching heating off, switching of fans.
- Choice of 3 functions:
1) ZR - Delay ON
2) ZN - Delay OFF
3) BL - Repeat Cycle
- Functions can be controlled by supply voltage or time scale control input
- Choice of 6 time ranges: (0.1 s - 1 s / 1 s - 10 s / 6 s - 60 s / 1 min - 10 min / 6 min - 60 min / 1 h - 10 hrs)
- Universal voltage range AC/DC 12 - 240 V or AC 230 V.
- Output contact: CRM-81J: 1x changeover/ SPDT 16 A
CRM-83J: 3x changeover/ 3PDT 8 A.
- Red LED output indicator.
- 1-MODULE, DIN rail mounting.

Description

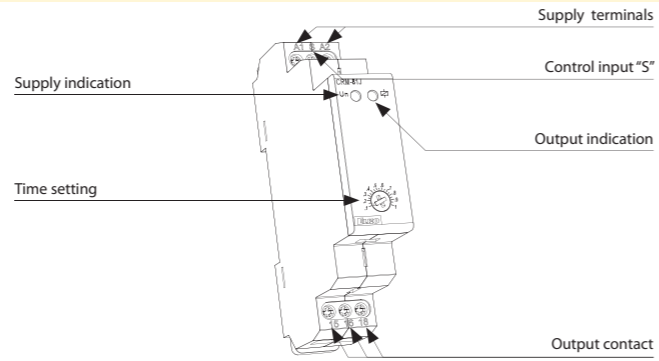

Functions

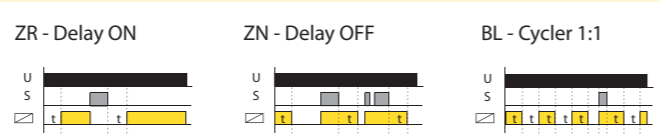

Note: the function ZR and ZN is controlled by supply voltage and control input ie. Once phase failure is detected and supply voltage is re applied, The relay automatically makes one cycle.

Connection

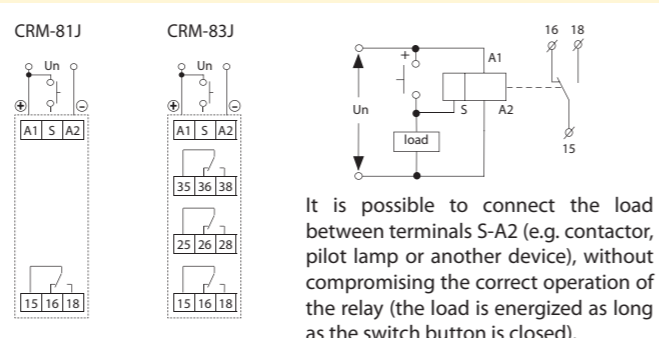

Symbol

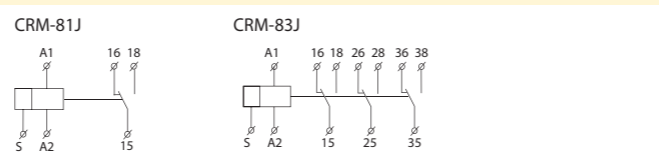

Example of an order

CRM-81J/230, ZR10s: 1x changeover contact, voltage AC 230 V, function: delay ON, time 1 - 10 s
CRM-83J/UNI, BL1h: 3x changeover contact, voltage AC/DC 12-240 V, function: cycler begin with impulse, time 6-60 min



EAN code
CRM-82TO /UNI: 8595188137614

Technical parameters	CRM-82TO
Number of functions:	a - On Delay (Power On) / e - Off Delay (S Break)
Supply terminals:	A1 - A2
Voltage range:	AC/DC 12 - 240 V (AC 50 - 60 Hz)
Burden:	AC 0.7 - 3 VA / DC 0.5 - 1.7 W
Supply voltage tolerance:	-15 %; +10 %
Supply indication:	green LED
Time ranges:	0.1 s - 10 min
Time setting:	potentiometer
Time deviation:	5 % - mechanical setting
Repeat accuracy:	0.2 % - set value stability
Temperature coefficient:	0.1 % / °C, at = 20 °C (0.1 % / °F, at = 68 °F)
Output	
Number of contacts:	2x changeover/DPDT (AgNi/ Silver Alloy)
Current rating:	8 A / AC1
Breaking capacity:	2000 VA / AC1, 192 W / DC
Inrush current:	10 A / <3 s
Switching voltage:	250 V AC1 / 24 V DC
Min. breaking capacity DC:	500 mW
Output indication:	red LED
Mechanical life:	3x10 ⁷
Electrical life (AC1):	0.7x10 ⁵
Other information	
Operating temperature:	-20 °C to 55 °C (-4 °F to 131 °F)
Storage temperature:	-30 °C to 70 °C (-22 °F to 158 °F)
Electrical strength:	4 kV (supply-output)
Operating position:	any
Mounting:	DIN rail EN 60715
Protection degree:	IP 40 from front panel / IP 10 terminals
Overvoltage category:	III.
Pollution degree:	2
Max. cable size (mm ²):	solid wire max. 2x 2.5 or 1x 4, with sleeve max. 2x 1.5 or 1x 2.5 (AWG 12)
Dimensions:	90 x 17.6 x 64 mm (3.5" x 0.7" x 2.5")
Weight:	93 g (3.3 oz.)
Standards:	EN 61812-1, EN 61010-1

- „True OFF“ relay - relay timing without supply voltage.
- Example of use: back-up source for Delay OFF in case of voltage failure (e.g. emergency lighting, emergency respirator, or protection of el. controlled doors - in case of fire).
- 2 time functions adjustable by rotary switch:
a - Delayed return after disconnecting of supply.
e - Delayed start.
- Time range (adjustable by rotary switch and fine setting by potentiometer): 0.1 s - 10 min.
- Universal supply voltage AC/DC 12 - 240 V.
- Interruptions in the power supply must take time steps (tens to hundreds of milliseconds).
- Output contact: 2x changeover / DPDT 8 A.
- Output status indicated by red LED (only in case of supply voltage connection).
- Clamp terminals.
- 1-MODULE, DIN rail mounting.

Description

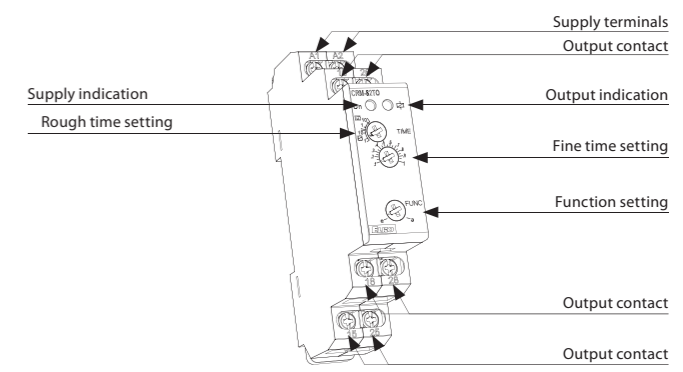

Function

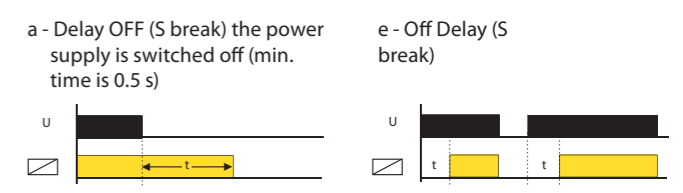

Connection

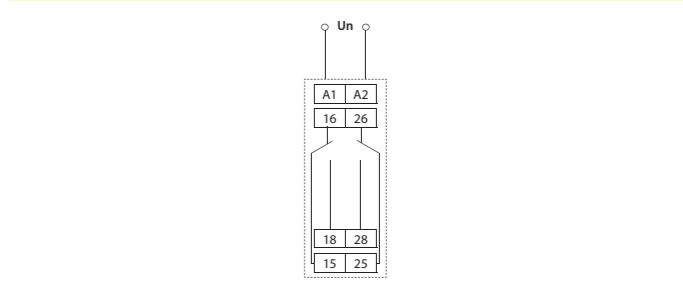

Symbol

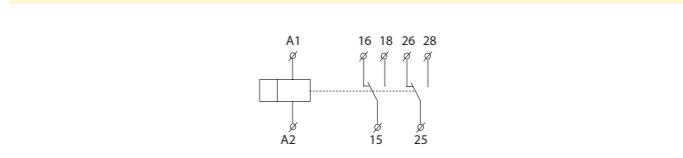



EAN code
SJR-2 /230 V: 8595188116015
SJR-2 /UNI: 8595188117401

Technical parameters		SJR-2
Number of functions:		2x delay ON
Supply terminals:		A1 - A2
Voltage range:	UNI	AC/DC 12 - 240 V (AC 50 - 60 Hz)
Burden:		AC 0.7 - 3 VA / DC 0.5 - 1.7 W
Voltage range:	230	AC 230 V / 50 - 60 Hz
Power input (apparent/loss):		AC max. 12 VA / 1.3 W
Supply voltage tolerance:		-15 %; +10 %
Supply indication:		green LED
Time ranges:		0.1 s - 10 days
Time setting:		rotary switch and potentiometer
Time deviation:		5 % - mechanical setting
Repeat accuracy:		0.2 % - set value stability
Temperature coefficient:		0.01 % / °C, at = 20 °C (0.01 % / °F, at = 68 °F)
Output		
Number of contacts:		2x changeover/ DPDT (AgNi / Silver Alloy)
Current rating:		16 A / AC1
Breaking capacity:		4000 VA / AC1, 384 W / DC
Inrush current:		30 A / < 3 s
Switching voltage:		250 V AC1 / 24 V DC
Min. breaking capacity DC:		500 mW
Output indication:		multifunction red LED
Mechanical life:		3x10 ⁷
Electrical life (AC1):		0.7x10 ⁵
Reset time:		max. 150 ms
Other information		
Operating temperature:		-20 °C to 55 °C (-4 °F to 131 °F)
Storage temperature:		-30 °C to 70 °C (-22 °F to 158 °F)
Electrical strength:		4 kV (supply-output)
Operating position:		any
Mounting:		DIN rail EN 60715
Protection degree:		IP 40 from front panel / IP 20 terminals
Overvoltage category:		III.
Pollution degree:		2
Max. cable size (mm ²):		solid wire max. 1x 2.5 or 2x1.5/ with sleeve max. 1x 2.5 (AWG 12)
Dimensions:		90 x 17.6 x 64 mm (3.5" x 0.7" x 2.5")
Weight:		UNI - 88 g (3.1 oz.), 230 - 83 g (2.9 oz.)
Standards:		EN 61812-1, EN 61010-1

- For gradual switching of high power (e.g. el.heating), prevents current strokes in the main.
- Function: 2x Delay ON (2 time relays in one).
- Time scale 0.1s - 10 days divided into 10 time ranges:
0.1s - 1s / 1s - 10s / 0.1min - 1min / 1min - 10min / 0.1h - 1h / 1h - 10hrs / 0.1 day - 1 day / 1 day - 10 days / ON / OFF
- Times t1 and t2 are independantly adjustable.
- t1 and t2 are switched on after supply voltage connection.
- Rough time setting via rotary switch.
- Voltage range: AC 230 V or AC/DC 12 - 240 V.
- Output contact: 2 x changeover / DPDT 16 A.
- Output indication: multifunction red LED, flashing at certain states.
- 1-MODULE, DIN rail mounting.

Description

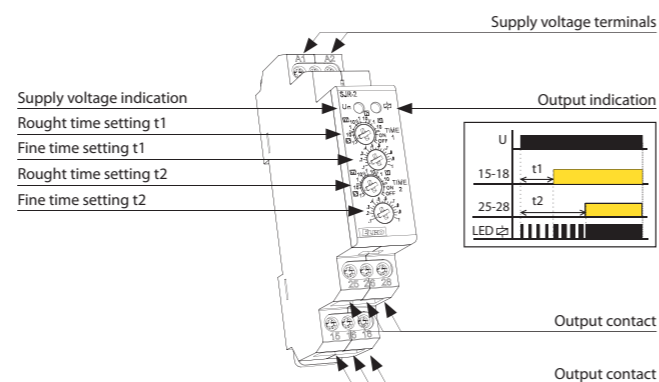

Function

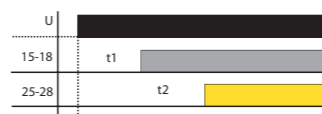

Connection



Symbol

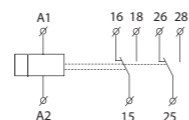

EAN code
CRM-2T /230 V: 8595188112291
CRM-2T /UNI: 8595188112437

Technical parameters		CRM-2T
Number of functions:		1
Supply terminals:		A1 - A2
Voltage range:	UNI	AC/DC 12 - 240 V / AC 50 - 60 Hz
Burden:		AC 0.7 - 3 VA / DC 0.5 - 1.7 W
Voltage range:	230	AC 230 V / 50 - 60 Hz
Burden:		AC max. 12 VA / 1.9 W
Operating range:		-15 %; +10 %
Supply indication:		green LED
Time scale:		t1: 0.1 s - 100 days, t2: 0.1 s-1 s
Time setting:		potentiometer
Time deviation:		5 % - mechanical setting
Repeat accuracy:		0.2 % - set value stability
Temperature coefficient:		0.01 % / °C, at = 20 °C (0.01 % / °F, at = 68 °F)
Output		
Number of contacts:		2x changeover/ DPDT (AgNi / Silver Alloy)
Current rating:		16 A / AC1
Breaking capacity:		4000 VA / AC1, 384 W / DC
Inrush current:		30 A / < 3 s
Switching voltage:		250 V AC1 / 24 V DC
Min. breaking capacity DC:		500 mW
Output indication:		multifunction red LED
Mechanical life:		3x10 ⁷
Electrical life (resistive):		0.7x10 ⁵
Reset time:		max. 150 ms
Other information		
Operating temperature:		-20 °C to 55 °C (-4 °F to 131 °F)
Storage temperature:		-30 °C to 70 °C (-22 °F to 158 °F)
Electrical strength:		4 kV (supply-output)
Operating position:		any
Mounting:		DIN rail EN 60715
Protection degree:		IP 40 from front panel / IP 20 terminals
Overvoltage category:		III.
Pollution degree:		2
Terminal wire capacity (mm ²):		max.1x 2.5, 2x1.5, with sleeve max. 1x 2.5 (AWG 12)
Dimensions:		90 x 17.6 x 64 mm (3.5" x 0.7" x 2.5")
Weight:		84 g (3 oz.)
Standards:		EN 61812-1, EN 61010-1

- It serves for delay ON of motors star/delta.
- Time t1 (star)
 - time scale 0.1 s - 100 days divided into 10 time ranges.
 - rough time setting by rotary switch
- Time t2 (delay) between \wedge / Δ :
 - time scale 0.1 s - 1 s
 - fine time setting by potentiometer
- Voltage range: AC 230 V, AC/DC 12 - 240 V.
- Output contact: 2x changeover / DPDT 16 A.
- Output indication: multifunction red LED.
- 1-MODULE, DIN rail mounting.

Description

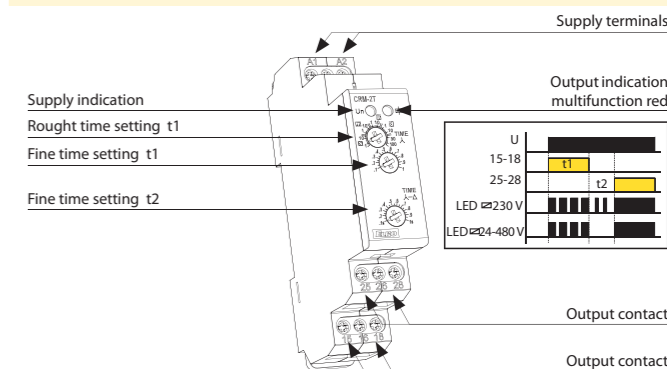

Function

Delay ON star / delta

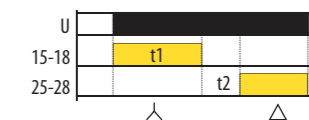

Connection

Start up of motor (\wedge - Δ)

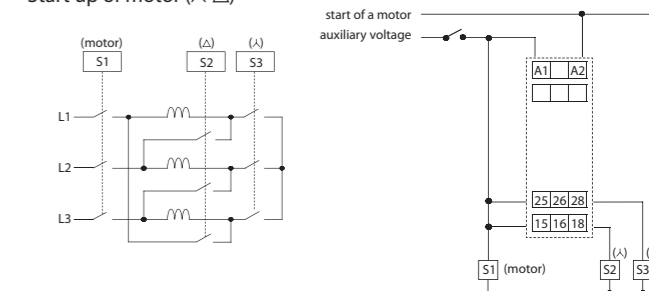

Symbol

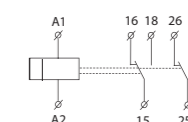



EAN code
CRM-2H /230 V: 8595188124201
CRM-2H /UNI: 8595188113007

Technical parameters CRM-2H

Number of functions:	2 (function is chosen by connecting S-A1)
Supply terminals:	A1 - A2
Voltage range:	UNI AC/DC 12 - 240 V (AC 50 - 60 Hz)
Burden:	AC 0.7 - 3 VA / DC 0.5 - 1.7 W
Voltage range:	230 AC 230 V / 50 - 60 Hz
Power input (apparent/loss input):	AC max. 12 VA / 1.3 W
Operating range:	-15 %; +10 %
Supply indication:	green LED
Time scale:	0.1 s - 100 days
Time setting:	rotary switch and potentiometer
Time deviation:	5 % - mechanical setting
Repeat accuracy:	0.2 % - set value stability
Temperature coefficient:	0.01 % / °C, at = 20°C (0.01 % / °F, at = 68°F)

Output

Number of contacts:	1x changeover/ SPDT (AgNi / Silver Alloy)
Current rating:	16 A / AC1
Breaking capacity:	4000 VA / AC1, 384 W / DC
Inrush current:	30 A / < 3 s
Switching voltage:	250 V AC1 / 24 V DC
Min. breaking capacity DC:	500 mW
Output indication:	multifunction red LED
Mechanical life:	3x10 ⁷
Electrical life (resistive):	0.7x10 ⁵
Reset time:	max. 150 ms

Other information

Operating temperature:	-20 °C to 55 °C (-4 °F to 131 °F)
Storage temperature:	-30 °C to 70 °C (-22 °F to 158 °F)
Electrical strength:	4 kV (supply-output)
Operating position:	any
Mounting:	DIN rail EN 60715
Protection degree:	IP 40 from front panel / IP 20 terminals
Overvoltage category:	III.
Pollution degree:	2
Terminal wire capacity (mm ²):	solid wire max. 1x 2.5 or 2x 1.5 / with sleeve max. 1x 2.5 (AWG 12)
Dimensions:	90 x 17.6 x 64 mm (3.5" x 0.7" x 2.5")
Weight	UNI - 65 g (2.3 oz.), 230 - 61 g (2.2 oz.)
Standards:	EN 61812-1, EN 61010-1

- Cycler with independent adjustable switch ON/OFF
- Used for regular room ventilation, cyclic dehumidification, light control, circulating pumps, illuminated advertising, etc.
- 2 time functions:
 - 1) Cycler beginning with pulse
 - 2) Cycler beginning with pause
- Function choice is done by an external jumper of terminals S-A1
- Time scale 0.1 s - 100 days divided into 10 time ranges: (0.1 s - 1 s / 1 s - 10 s / 0.1 min - 1 min / 1 min - 10 min / 0.1 hrs - 1 h / 1 hrs - 10 hrs / 0.1 day - 1 day / 1 day - 10 days / 3 days - 30 days / 10 days - 100 days)
- Rough time setting via rotary switch
- Voltage range: AC 230 V or AC/DC 12 - 240 V
- Output contact: 1x changeover / SPDT 16 A
- Output indication: multifunction red LED
- 1-MODULE, DIN rail mounting

Description

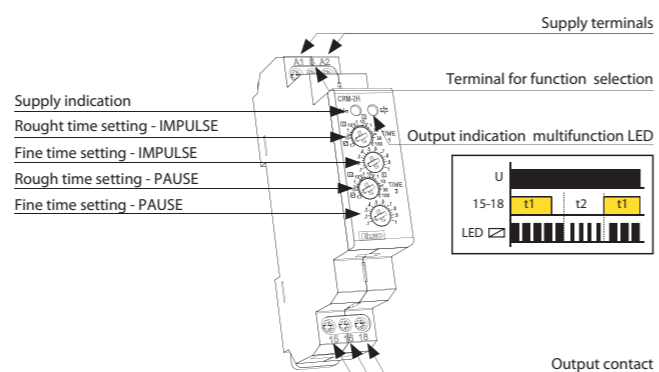

Function

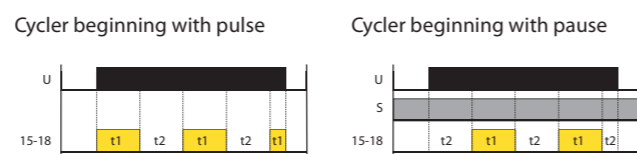

Connection

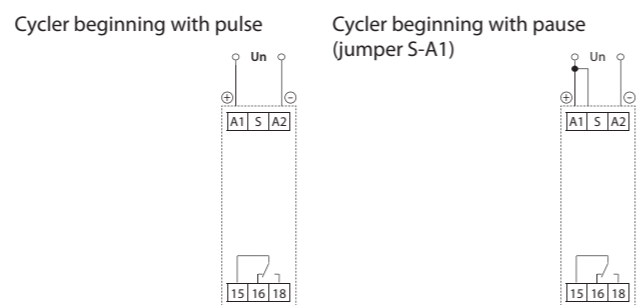

Symbol

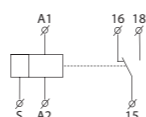

EAN code
CRM-61 /UNI: 8595188120210

Technical parameters CRM-61

Number of functions:	6
Supply terminals:	A1 - A2
Supply voltage :	AC 24 - 240 V (AC 50 - 60 Hz) and DC 24 V
Burden:	AC 0.7 - 3 VA / DC 0.5 - 1.7 W
Supply voltage tolerance:	15 %; +10 %
Supply indication:	green LED
Time ranges:	0.1 s - 10 h
Time setting:	rotary switch and potentiometer
Time deviation:	5 % - mechanical setting
Repeat accuracy:	0.2 % - set value stability
Temperature coefficient:	0.01 % / °C, at = 20°C (0.01 % / °F, at = 68°F)

Output

Number of contacts:	1x changeover/ SPDT (AgNi / Silver Alloy)
Current rating:	8 A / AC1
Breaking capacity:	2500 VA / AC1, 240 W / DC
Output indication:	multifunction red LED
Mechanical life:	1x10 ⁷
Electrical life (AC1):	1x10 ⁵

Controlling

Control. voltage:	UNI
Control power input:	AC 0.025 - 0.2 VA / DC 0.1 - 0.7 W
Load between S-A2:	Yes
Glow-tubes:	No
Control. terminals:	A1-S
Max. capacity of cable control:	0.1 μF
Impulse length:	min. 25 ms / max. unlimited
Reset time:	max. 120 ms

Other information

Operating temperature:	-20 °C to +55 °C (-4 °F to 131 °F)
Storage temperature:	-30 °C to +70 °C (-22 °F to 158 °F)
Electrical strength:	4 kV (supply-output)
Operating position:	any
Mounting:	DIN rail EN 60715
Protection degree:	IP 40 from front panel / IP 10 terminals
Overvoltage category:	III.
Pollution degree:	2
Max. cable size (mm ²):	max. 2x 2.5, max. 1x 4 with sleeve max. 1x 2.5, 2x 1.5 mm ² (AWG 12)
Dimensions:	90 x 17.6 x 64 mm (3.5" x 0.7" x 2.5")
Weight:	69 g (2.4 oz.)
Standards:	EN 61812-1, EN 61010-1

Symbol

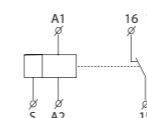

- Multifunction time relay (6 functions and 6 time ranges), economic version of CRM-91H
- To be used for electrical appliances, control of lights, heating, motors, pumps, fans, etc.
- 6 functions:
 - 3 time functions controlled by supply voltage
 - 3 time functions controlled by control input
- Easy to use function and time-range setting by rotary switches
- Time scale 0.1 s - 10 hrs divided into 6 range: (0.1 s - 1 s / 1 s - 10 s / 0.1 min - 1 min / 1 min - 10 min / 0.1 hrs - 1 hrs / 1 hrs - 10 hrs)
- Universal voltage range: AC 24 - 240 V, DC 24 V
- Output contact: 1x changeover 8 A / SPDT
- Multifunction red LED output indicator flashes or shines depending on the status of output
- 1-MODULE, DIN rail mounting

Description

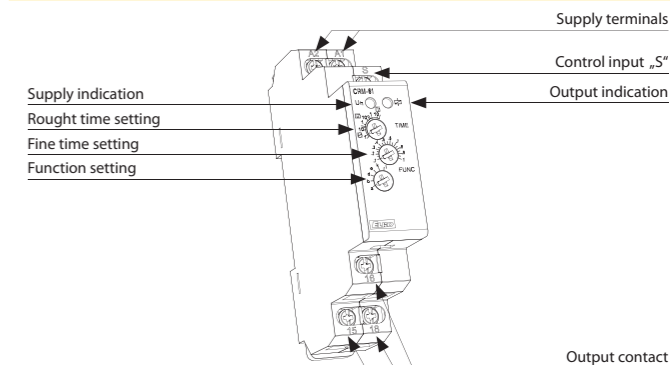

Function

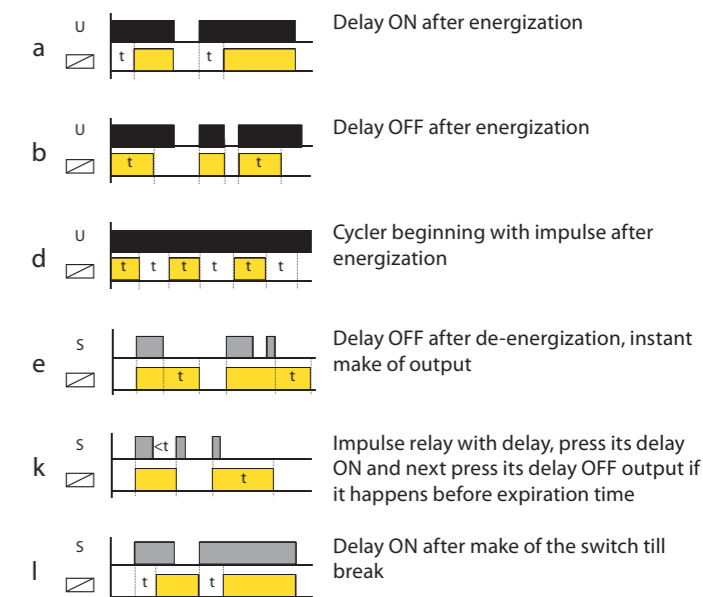

Connection

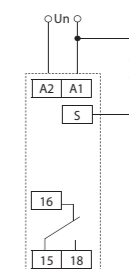



EAN code
 CRM-91 /230 V: 8595188112444
 CRM-91 /UNI: 8595188112420
 CRM-93H /230 V: 8595188112789
 CRM-93H /UNI: 8595188112468
 CRM-9S /UNI: 8595188116008

Technical parameters CRM-91H CRM-93H CRM-9S

Number of functions:	10		
Supply terminals:	A1 - A2		
Voltage range:	AC/DC 12 - 240 V (AC 50 - 60 Hz)	AC 12-240 V (50-60 Hz)	
Burden:	AC 0.7 - 3 VA / DC 0.5 - 1.7 W	AC max. 12VA / 1.3W	
Voltage range:	AC 230 V / 50 - 60 Hz	AC max. 12VA / 1.9W	
Consumption (apparent / loss):	AC max. 12VA / 1.3W	AC max. 12VA / 1.9W	x
Supply voltage tolerance:	-15 %; +10 %	x	
Supply indication:	green LED		
Time ranges:	0.1 s - 10 days		
Time setting:	rotary switch and potentiometer		
Time deviation:	5 % - mechanical setting		
Repeat accuracy:	0.2 % - set value stability		
Temperature coefficient:	0.01 % / °C, at = 20 °C (0.01 % / °F, at = 68 °F)		

Output

Number of contacts:	1x changeover/ SPDT (AgNi / Silver Alloy)	3x changeover/ SPDT (AgNi / Silver Alloy)	1x static contactless output (triac)
Current rating:	16 A / AC1	8 A / AC1	0.7 A
Breaking capacity:	4000 VA / AC1, 384 W / DC	2000 VA / AC1, 192 W / DC	0.7 A
Inrush current:	30 A / < 3 s	10 A / < 3 s	x
Switching voltage:	250 V AC1 / 24 V DC	60 A / < 10 ms	
Min. breaking capacity DC:	500 mA	x	
Voltage drop on switch:	x	x	
Load on B1 terminal:	x	max. 0.9 V at I max.	
Output indication:	multifunction red LED Yes / I max. 0.7 A		
Mechanical life:	3x10 ⁷	x	
Electrical life (AC1):	0.7x10 ⁸	> 10 ⁸	

Controlling

Power on control input:	AC 0.025 - 0.2 VA / DC 0.1 - 0.7 W (UNI), AC 0.53 VA (AC 230 V), AC 0.025 - 0.2 VA (AC 12 - 240 V)
Load between S-A2:	Yes
Control terminals:	A1-S
Glow tubes connections:	230 V - Yes / UNI - No
Max. amount of glow lamps connected to controlling input:	UNI - glow lamps cannot connected/NO 230 V - max.20 pcs (measured with glow lamp 0.68 mA / 230 V AC) glow lamps cannot connected/NO
Impulse length:	min. 25 ms / max. unlimited
Reset time:	max. 150 ms

Other information

Operating temperature:	-20 °C to +55 °C (-4 °F to 131 °F)
Storage temperature:	-30 °C to +70 °C (-22 °F to 158 °F)
Electrical strength:	4kV (supply-output)
Operating position:	any
Mounting:	DIN rail EN 60715
Protection degree:	IP 40 from front panel / IP 20 terminals
Overvoltage category:	III.
Pollution degree:	2
Max. cable size (mm ²):	solid wire max. 1x 2.5 or 2x 1.5 / with sleeve max. 1x 2.5 (AWG 12)
Dimensions:	90 x 17.6 x 64 mm (3.5" x 0.7" x 2.5")
Weight:	(UNI)-64 g (2.26 oz.); (UNI)-89 g (3.1 oz.); (230)-62 g (2.2 oz.); (230)-87 g (3 oz.); 51 g (1.8 oz.)
Standards:	EN 61812-1, EN 61010-1

- Multifunction time relay can be used for electrical appliances, control of lights, heating, motors, pumps and fans (10 functions, 10 time ranges, multi-voltage, 16 A or 3x 8 A contacts)
- Fulfills all requirements for time relays
- 10 functions:
 - 5 time functions controlled by supply voltage
 - 4 time functions controlled by control input
 - 1 function of latching relay
- Comfortable and well-arranged function and time-range setting by rotary switches
- Time scale 0.1 s - 10 days divided into 10 ranges: (0.1 s - 1 s / 1 s - 10 s / 0.1 min - 1 min / 1 min - 10 min / 0.1 hrs - 1 hrs / 1 hrs - 10 hrs / 0.1 day - 1 day / 1 day - 10 days / only ON / only OFF)
- CRM-91H, CRM-93H:**
 - universal supply voltage AC/DC 12 - 240 V or AC 230 V,
 - Output contact: CRM-91H: 1x changeover/SPDT 16 A;
 - CRM-93H: 3 x changeover/SPDT 8 A
- CRM-9S:**
 - universal supply voltage AC 12 - 240 V AC 12 - 240 V, absolutely noise-less switching
 - 1x static contactless output (triac) 0.7 A (60 A / < 10 ms), switches potential A1
- Multifunction red LED output indicator flashes or shines depending on the status of output
- 1-MODULE, DIN rail mounting

Description

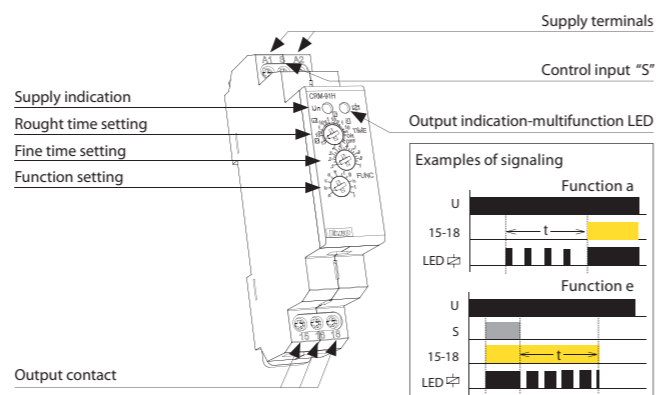

Connection

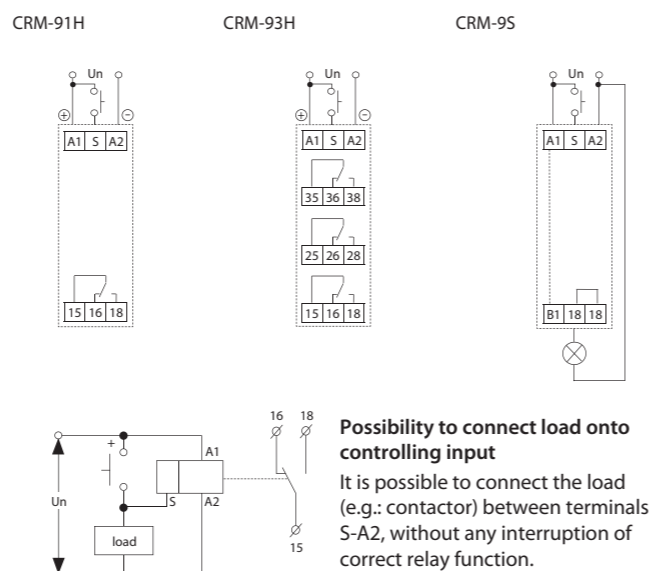

Possibility to connect load onto controlling input
 It is possible to connect the load (e.g.: contactor) between terminals S-A2, without any interruption of correct relay function.

Symbol

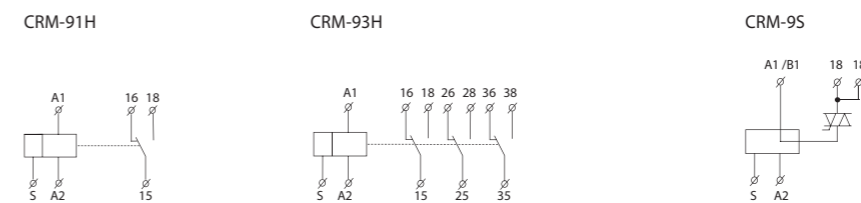

Function

a On Delay (Power On)
 When the input voltage U is applied, timing delay t begins. Relay contacts R change state after time delay is complete. Contacts R return to their shelf state when input voltage U is removed. Trigger switch S is not used in this function.

b Off Delay
 When input voltage U is applied, relay contacts R change state immediately and timing cycle begins. When time delay is complete, contacts return to shelf state. When input voltage U is removed, contacts will also return to their shelfstate. Trigger switch is not used in this function.

c Repeat Cycle (Starting Off)
 When input voltage U is applied, time delay t begins. When time delay t is complete, relay contacts R change state for time delay t. This cycle will repeat until input voltage U is removed. Trigger switch is not used in this function.

d Repeat Cycle (Starting On)
 When input voltage U is applied, relay contacts R change state immediately and time delay t begins. When time delay t is complete, contacts return to their shelf state for time delay t. This cycle will repeat until input voltage U is removed. Trigger switch is not used in this function.

e Off Delay (S Break)
 Input voltage U must be applied continuously. When trigger switch S is closed, relay contacts R change state. When trigger switch S is opened, delay t begins. When delay t is complete, contacts R return to their shelf state. If trigger switch S is closed before time delay t is complete, then time is reset. When trigger switch S is opened, the delay begins again, and relay contacts R remain in their energized state. If input voltage U is removed, relay contacts R return to their shelf state.

f Single Shot
 Upon application of input voltage U, the relay is ready to accept trigger signal S. Upon application of the trigger signal S, the relay contacts R transfer and the preset time t begins. During time-out, the trigger signal S is ignored. The relay resets by applying the trigger switch S when the relay is not energized.

g Single Shot Trailing Edge (Non-Retriggerable)
 Upon application of input voltage U, the relay is ready to accept trigger signal S. Upon application of the trigger signal S, the relay contacts R transfer and the preset time t begins. At the end of the preset time t, the relay contacts R return to their normal condition unless the trigger switch S is opened and closed prior to time out t (before preset time elapses). Continuous cycling of the trigger switch S at a rate faster than the preset time will cause the relay contacts R to remain closed. If input voltage U is removed, relay contacts R return to their shelf state.

h On/Off Delay
 Input voltage U must be applied continuously. When trigger switch S is closed, time delay t begins. When time delay t is complete, relay contacts R change state and remain transferred until trigger switch S is opened. If input voltage U is removed, relay contacts R return to their shelf state.

i Latching relay
 Input voltage U must be applied continuously. Output changes state with every trigger switch S closure. If input voltage U is removed, relay contacts R return to their shelf state.

j Pulse generator
 Upon application of input voltage U, a single output pulse of 0.5 seconds is delivered to relay after time delay t. Power must be removed and reapplied to repeat pulse. Trigger switch is not used in this function.

Time ranges

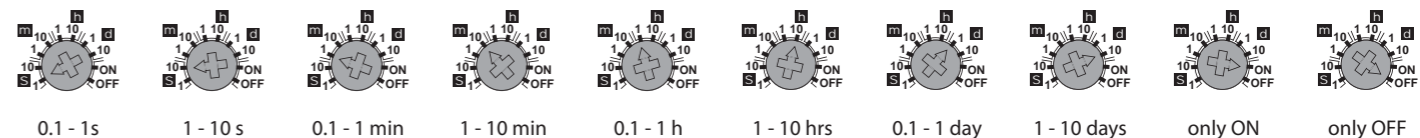

Notes

- Output contacts of CRM-93H do not allow switching of different phases or 3-phase voltages (voltage > 250 V).
- When mounting into steal-plated switchboards, it is necessary to keep a safety distance of min. 3 mm from terminal's screws 35-36-38 and 25-26-28 towards the shutter of a switchboard.



EAN code
CRM-91HE /UNI + potentiometr: 8595188142052
CRM-2HE /UNI + potentiometr: 8595188142069
Potentiometr for CRM-91HE, CRM-2HE : 8595188125215

Technical parameters	CRM-91HE	CRM-2HE
Number of functions:	10	2
Supply terminals:	A1 - A2	
Voltage range:	AC/DC 12 - 240 V (AC 50 - 60 Hz)	
Burden:	AC 0.7 - 3 VA / DC 0.5 - 1.7 W	
Supply voltage tolerance:	-15 %; +10 %	
Supply indication:	green LED	
Time ranges:	0.1 s - 10 days	0.1 s - 100 days
Time setting:	rotary switch, external potentiometer	
Time deviation:	5% - mechanical setting	
Repeat accuracy:	0.2 % - set value stability	
Temperature coefficient:	0.01 % / °C, at = 20°C (0.01% / °F, at = 68°F)	
Output		
Number of contacts:	1x changeover/ SPDT (AgNi / Silver Alloy)	
Current rating:	16 A / AC1	
Breaking capacity:	4000 VA / AC1, 384 W / DC	
Inrush current:	30 A / <3 s	
Switching voltage:	250 V AC1 / 24 V DC	
Min. breaking capacity DC:	500 mW	
Output indication:	multifunction red LED	
Mechanical life:	3x10 ⁷	
Electrical life (AC1):	0.7x10 ⁵	
Controlling		
Control. voltage:	UNI	
Consumption of input:	AC 0.025-0.2 VA / DC 0.1-0.7 W	
Load between S-A2:	Yes	
Glow-tubes:	No	
Control. terminals:	A1-S	
Impulse length:	min. 25 ms / max. unlimited	
Reset time:	max. 150 ms	
Other information		
Operating temperature:	-20 °C to +55 °C (-4 °F to 131 °F)	
Storage temperature:	-30 °C to +70 °C (-22 °F to 158 °F)	
Electrical strength:	4 kV (supply - output)	
Operating position:	any	
Mounting:	DIN rail EN 60715	
Protection degree:	IP 40 from front panel / IP 20 terminals	
Overvoltage category:	III.	
Pollution degree:	2	
Max. cable size (mm ²):	solid wire max. 1x 2.5 or 2x 1.5 / with sleeve max. 1x 2.5 (AWG 12)	
Dimensions:	90 x 17.6 x 64 mm (3.5" x 0.7" x 2.5")	
Weight:	77 g (2.7 oz.)	78 g (2.8 oz.)
Standards:	EN 61812-1, EN 61010-1	
Potentiometer		
Potentiometer:	47 kΩ, linear	
Protection degree:	IP 65 from front side / IP 20 from back side	
Max. cable size (mm ²):	1.5 with sleeve / without sleeve max. 2.5 (AWG 12)	
Weight:	15 g (0.5 oz.)	
Dimensions:	see page Accessories	

- Control by external control unit - potentiometer (can be placed/ mounted for example on switch board doors or in panel).
- CRM-91HE:** multifunction time relays
 - 10 functions :
 - 5 time functions controlled by supply voltage
 - 4 time functions controlled by control input
 - 1 function of latching relay
 - time scale 0.1 s - 10 days divided into 10 ranges (0.1 s - 1 s / 1 s - 10 s / 0.1 min - 1 min / 1 min - 10 min / 0.1 hrs - 1 hrs / 1 hrs - 10 hrs / 0.1 day - 1 day / 1 day - 10 days / only ON / only OFF).
- CRM-2HE:** asymmetric cycler
 - 2 time functions:
 - cycler beginning with pulse
 - cycler beginning with gap
 - function selected via external wired link on control input S-A1.
- Universal supply voltage AC/DC 12 - 240 V.
- Output contact: 1x changeover 16 A/SPDT.
- 1-MODULE, DIN rail mounting.
- Possible to connect external potentiometer - max. distance 10 m (32.8 ft.) from relay

Description

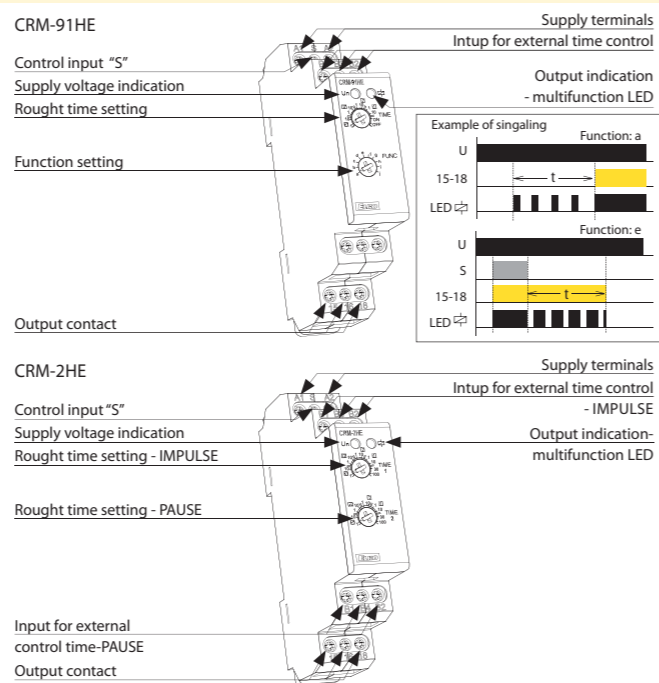

Function

Functions of CRM-91HE are identical with CRM-91H.
Functions of CRM-2HE are identical with CRM-2H.

Connection

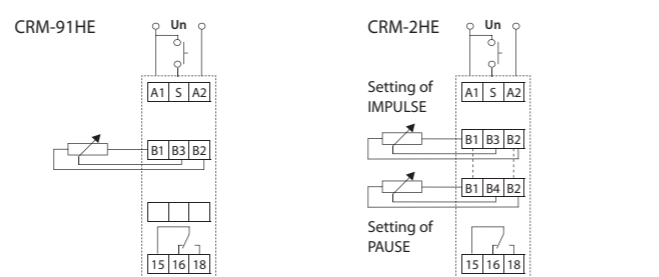

Symbol

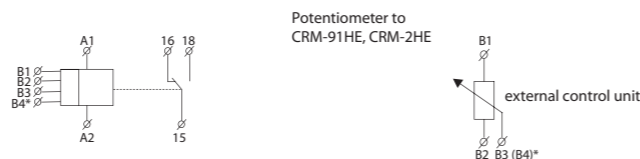

*B4 only for CRM-2HE



EAN code
PRM-91H-8/UNI: 8595188135511
PRM-91H-11/UNI: 8595188111638
PRM-92H/UNI: 8595188111096
PRM-2H/UNI: 8595188111645

Technical parameters	PRM-91H/8	PRM-91H/11	PRM-92H	PRM-2H
Number of functions:	10			
Supply:	pins 2 and 7	pins 2 and 10	pins 2 and 10	pins 2 and 10
Voltage range:	AC/DC 12 - 240 V (AC 50 - 60 Hz)			
Burden:	AC 0.7 - 3 VA / DC 0.5 - 1.7 W			
Supply voltage tolerance:	-15 %; +10 %			
Supply indication:	green LED			
Time ranges:	0.1 s - 10 days			0.1 s - 100 days
Time setting:	rotary switch and potentiometer			
Time deviation:	5 % - mechanical setting			
Repeat accuracy:	0.2 % - set value stability			
Temperature coefficient:	0.01 % / °C, at = 20 °C (0.01 % / °F, at = 68 °F)			
Output				
Number of contacts:	1x changeover/ SPDT (AgNi / Silver Alloy)		2x changeover/ DPDT (AgNi / Silver Alloy)	
Current rating:	16 A / AC1		8 A / AC1	
Breaking capacity:	4000 VA / AC1, 384 W / DC		2000 VA / AC1, 192 W / DC	
Inrush current:	30 A / <3 s		10 A / <3 s	
Switching voltage:	250 V AC1 / 24 V DC			
Min. breaking capacity DC:	500 mW			
Output indication:	multifunction red LED			
Mechanical life:	3x10 ⁷			
Electrical life (AC1):	0.7x10 ⁵			
Control				
Control. voltage:	in the supply voltage range			
Control power input:	AC 0.025 - 0.2 VA / DC 0.1 - 0.7 W (UNI)			
Load between S-10:	Yes			
Glow-tubes:	No			
Control terminals:	2-5			
Max. capacity of cable control:	-without connected glow-lamps: 0.1µF			
Impulse length:	min. 25 ms / max. unlimited			
Reset time:	max. 150 ms			
Other information				
Operating temperature:	-20 .. +55 °C			
Storage temperature:	-30 .. +70 °C			
Electrical strength:	2.5 kV			
Operating position:	any			
Mounting:	DIN rail EN 60715			
Protection degree:	IP 40 from front panel			
Overvoltage category:	III.			
Pollution degree:	2			
Dimensions:	50 x 38 x 53 mm			
Weight:	57 g	57 g	58 g	58 g
Standards:	EN 61812-1, EN 61010-1			
Time ranges				
Time ranges of PRM-91H, PRM-92H are identical with CRM-91H. See page 17. Time ranges of PRM-2H are identical with CRM-2H. See page 14.				

- Multifunction time relays are equivalents by module types of relay, designed to standardized plug 11 or 8 pin socket
- Pin type enables easy changing, replacement older type of relays (pin-compatible) or easy changing auxiliary relay for time relays
- Multifunction time relay **PRM-91H**
 - 8 or 11 pin type
 - 10 time functions, time scale from 0.1 s to 10 days is divided into 10 ranges
 - output contact 1x 16 A / 4000 VA, 250 V AC1
- Multifunction time relay **PRM-92H**
 - 11 pin type
 - 10 time functions, time scale from 0,1 s to 10 days is divided into 10 ranges
 - output contact 2x 8 A / 2000 VA, 250 V AC1
- Asymmetric cycler **PRM-2H**
 - 11 pin type
 - 2 time functions, time scale from 0,1 s to 100 days is divided into 10 ranges
 - output contact 2x 8 A / 2000 VA, 250 V AC1
- Universal supply voltage AC/DC 12 - 240 V
- Output indication: multif. red LED, flashing at certain states
- PLUG-IN relays

Description

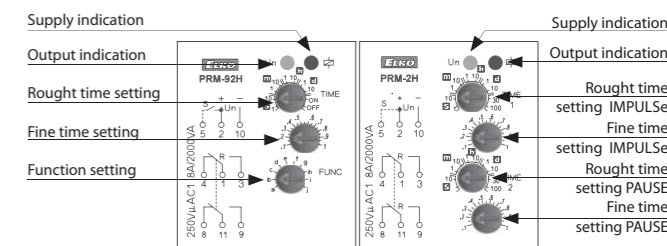

Functions

PRM-91H, PRM-92H: Functions of PRM-91H, PRM-92H are identical with CRM-91H. See page 16.

PRM-2H: Choice Function in PRM-2H is done by connecting terminals 2 and 5.

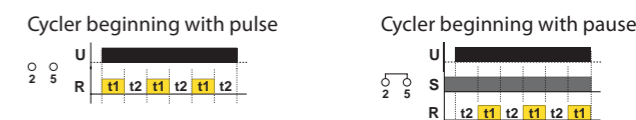

Connection

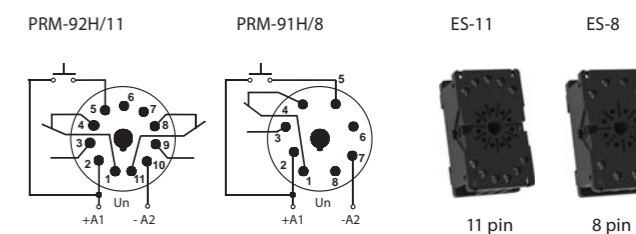

Symbol

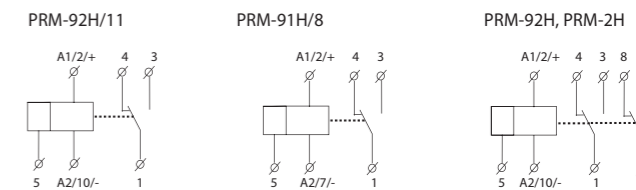

LEGEND TO DESCRIPTION
polarity- outputs/number on module/on socket



EAN code
 PDR-2A /230 V: 859403033037
 PDR-2A /UNI: 859403033044
 PDR-2B /230 V: 859403033051
 PDR-2B /UNI: 859403033068

Technical parameters	PDR-2/A	PDR-2/B
Function:	16	10
Supply terminals:	A1 - A2	
Voltage range:	AC/DC 12 - 240 V (AC 50 - 60 Hz)	
Burden:	AC 0.5 - 2.5 VA / DC 0.4 - 2.5 W	
Voltage range:	AC 230 V / 50 - 60 Hz	
Consumption (apparent/loss):	AC max. 16 VA / 2.5 W	
Supply voltage tolerance:	-15 %; +10 %	
Time ranges:	0.01 s - 100 h	
Repeat accuracy:	0.2 % - set value stability	
Temperature coefficient:	0.01 % / °C, at = 20 °C (0.01 % / °F, at = 68 °F)	
Output		
Number of contacts:	2x changeover/ SPDT (AgNi / Silver Alloy)	
Current rating:	16 A / AC1	
Breaking capacity:	4000 VA / AC1, 384 W / DC	
Inrush current:	30 A / < 3 s	
Switching voltage:	250 V AC1 / 24 V DC	
Min. breaking capacity DC:	500 mW	
Output indication:	red LED	
Mechanical life:	3x10 ⁷	
Electrical strength (AC1):	0.7x10 ⁵	
Control		
Control input Burden:	AC 0.01 - 0.25 VA (UNI), AC 0.25 VA (AC 230 V)	
Glow lamps:	No	
Control impulse length:	min. 1 ms / max. unlimited	
Reset time:	max. 200 ms	
Display - colour:	red	
Number and height of digits:	4 positions with separating colon, height 10 mm (0.39")	
Luminance:	2200 - 3800 ucd	
Light wavelength:	635 nm	
Brightness setting:	range 20 - 100 % in 10 steps adjustable	
Memory - memory locations:	30 (PDR-2/A) / 20 (PDR-2/B) for times ranges + service function	
Data stored for:	min. 10 years	
Other information		
Operating temperature:	-20 °C to +55 °C (-4 °F to 131 °F)	
Storage temperature:	-30 °C to +70 °C (-22 °F to 158 °F)	
Electrical strength:	4 kV (supply - output)	
Operating position:	any	
Mounting:	DIN rail EN 60715	
Protection degree:	IP 40 from front panel / IP 20 terminals	
Overvoltage category:	III.	
Pollution degree:	2	
Max. cable size (mm ²):	solid wire max. 1x 2.5 or 2x 1.5 / with sleeve max. 1x 1.5 (AWG 12)	
Dimensions:	90 x 52 x 65 mm (3.5" x 2" x 2.6")	
Weight:	(UNI) - 143 g (5 oz.), (230) - 134 g (4.7 oz.)	
Standards:	EN 61812-1, EN 61010-1	

- Multifunction programmable digital relay with 4 digit red LED display.
- Control and setting are done by 3 buttons, user-friendly menu, absolute accuracy in timer setting, time countdown on a display, galvanically separated START and STOP control inputs with UNI supply.
- Thanks to its complexity, it is possible to program also more demanding time functions by using 2 independent times.
- 2 independent times, with combination of 2 inputs and 2 outputs.
- PDR-2/A: 16 functions, choice of functions of the other relay, 30 memory places for most frequently used times.
- PDR-2/B: 10 functions, 1 output of 10 functions can be assigned to each relay = 2 relays in one device.
- 2 independent times in range: 0.01 s - 100 hrs.
- Supply voltage AC/DC 12 - 240 V or AC 230 V.
- 3-MODULE, DIN rail mounting.

Description

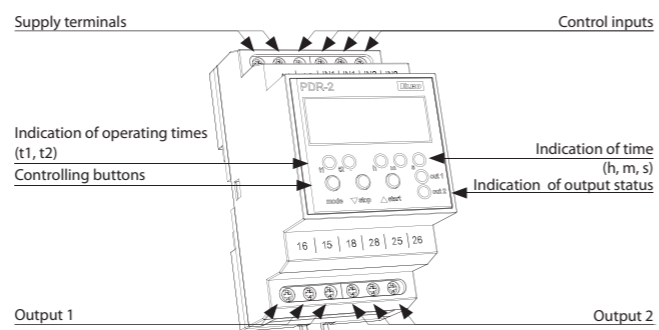

Symbol

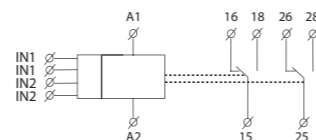

Time data

Time range:	0.01 s - 99 h 59 min 59 sec 99 ss
Minimal time step:	0.01 s
Time deviation:	0.01 % of set value
Setting error:	0 %
Setting, reset accuracy:	100 %
Digital places:	selected via program

Connection

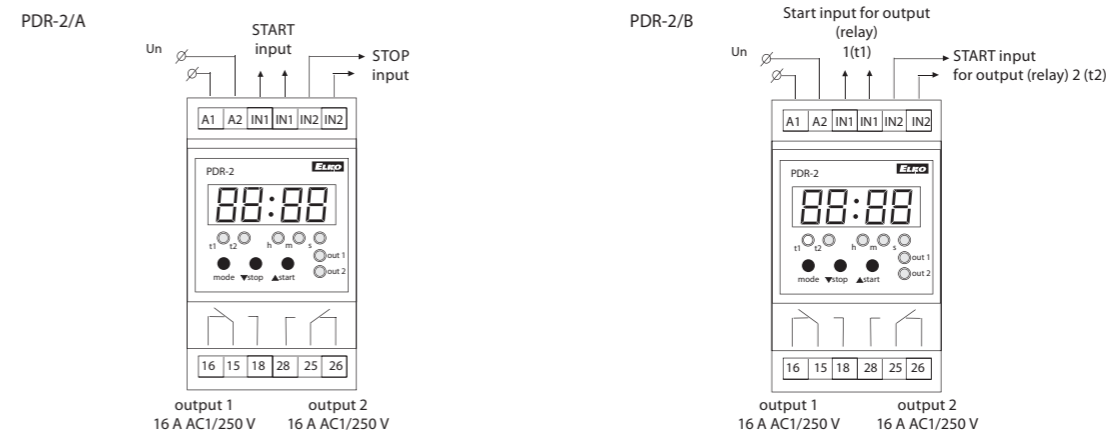

Function

Functions for PDR-2/A and PDR-2/B

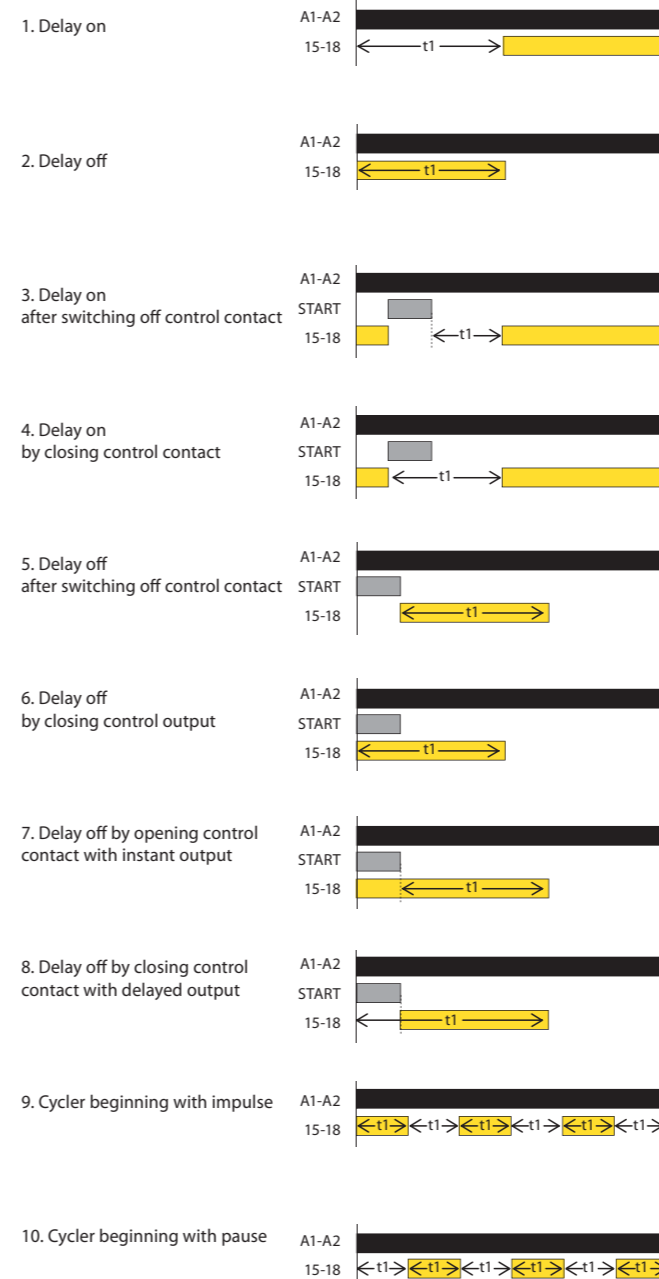

Functions for PDR-2/A

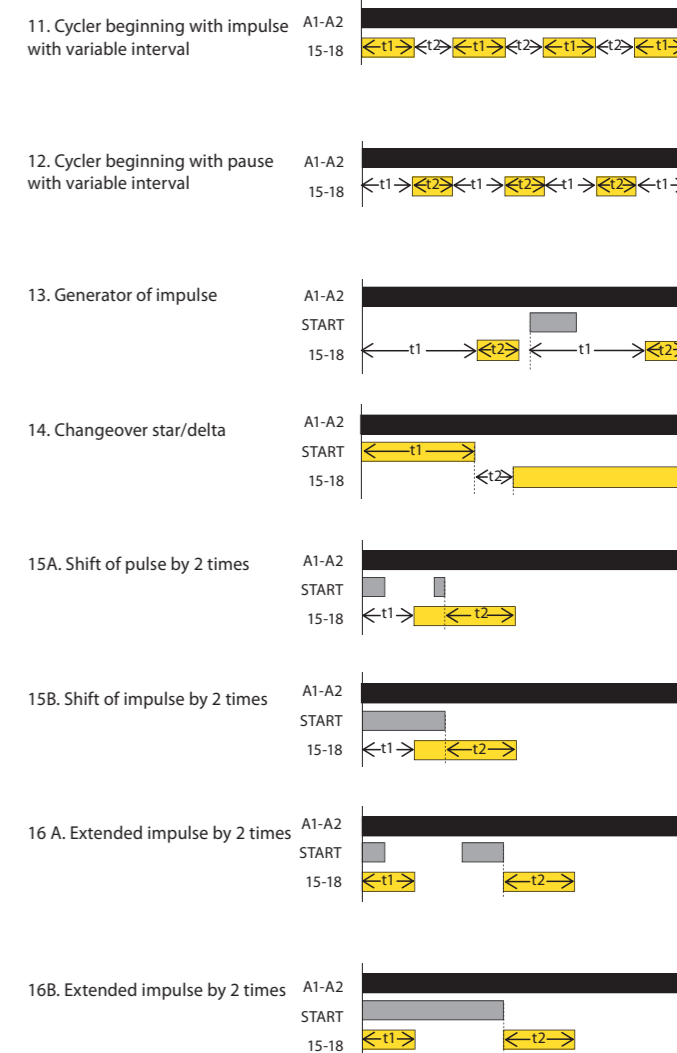

Recommendation:
 PDR-2/B is replacing by 2 simple time relays = 2 in one.



EAN code
 SHT-1 /230 V: 8595188130424
 SHT-1 /UNI: 8595188130431
 SHT-1/2 /230 V: 8595188130400
 SHT-1/2 /UNI: 8595188130417
 SHT-3 /230 V: 8595188136761
 SHT-3 /UNI: 8595188136754
 SHT-3/2 /230 V: 8595188129015
 SHT-3/2 /UNI: 8595188129046

Technical parameters	SHT-1, SHT-3	SHT-1/2, SHT-3/2
Supply terminals:	A1 - A2	
Voltage range:	UNI	AC/DC 12 - 240 V (AC 50 - 60 Hz)
Burden:	AC 0.5 - 2 VA / DC 0.4 - 2 W	
Voltage range:	230	AC 230 V / 50 - 60 Hz
Burden:	AC max. 14 VA / 2 W	
Supply voltage tolerance:	-15 %; +10 %	
Back-up supply:	yes	
Summer/winter time:	automatic	
Output		
Number of contacts:	1x changeover/SPDT (AgSnO ₂) 2x changeover/SPDT (AgSnO ₂)	
Current rating:	16 A / AC1	
Breaking capacity:	4000 VA / AC1, 384 W / DC	
Inrush current:	30 A / < 3 s	
Switching voltage:	250 V AC1 / 24 V DC	
Min. breaking capacity DC:	500 mW	
Mechanical life:	> 3x10 ⁷	
Electrical life (AC1):	> 0.7x10 ⁵	
Time circuit		
Power back-up:	up to 3 years	
Accuracy:	max. ±1s / day at 23 °C (73.4 °F)	
Minimum interval:	1 min	
Data stored for:	min. 10 years	
Cyclic output:	1 - 99 s	
Pulse output:	1 - 99 s	
Program circuit		
Number of memory places:	100	
Program (SHT-1; SHT-1/2):	daily, weekly	
Program (SHT-3; SHT-3/2):	daily, weekly, monthly, yearly (up to year 2095)	
Data readout:	LCD display, with backlight	
Other information		
Operating temperature:	-20 °C to +55 °C (-4 °F to 131 °F)	
Storage temperature:	-30 °C to +70 °C (-22 °F to 158 °F)	
Electrical strength:	4 kV (supply - output)	
Operating position:	any	
Mounting:	DIN rail EN 60715	
Protection degree:	IP 10 clips, IP 40 from front panel	
Overvoltage category:	III.	
Polution degree:	2	
Max. cable size (mm ²):	solid wire max. 2x 2.5 or 1x 4 with sleeve max. 1x 2.5 or 2x 1.5 (AWG 12)	
Dimensions:	90 x 35.6 x 64 mm (3.5" x 1.4" x 2.5")	
Weight:	(UNI) - 130 g (4.6 oz.), (230) - 110 g (3.9 oz.) (UNI) - 143 g (5 oz.), (230) - 125 g (4.4 oz.)	
Standards:	EN 61812-1, EN 61010-1	

- This time switch clock SHT is used to control various appliances in real time; daily, weekly, monthly and yearly mode.
- Switching: according the program (AUTO)/constantly manually, manually to next program change/random (CUBE).
- „Holiday program“ option to choose an interval when the device doesn't switch according to the standard program, but will be block during that time.
- Automatic conversion summer / winter time.
- Sealable cover of front panel, easy controlling via 4 buttons.
- 100 memory places, clear LCD display, min. interval 1 s.
- Voltage range: AC 230 V or AC/DC 12-240 V.
- Cyclic output.
- Pulse output.
- SHT-1, SHT-3: one channel version, 2-MODULE, DIN rail mounting, clamp terminals.
- SHT-1/2, SHT-3/2: two channel version, 2-MODULE, an individual program can be run on each channel.

	Output		Time programm			
	1 channel	2 channel	day	week	month	year
SHT-1	•		•	•		
SHT-1/2		•	•	•		
SHT-3	•		•	•	•	•
SHT-3/2		•	•	•	•	•

Description

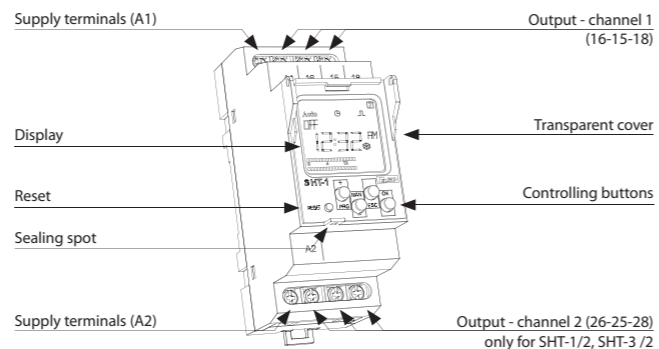

Description of displayed elements on the screen

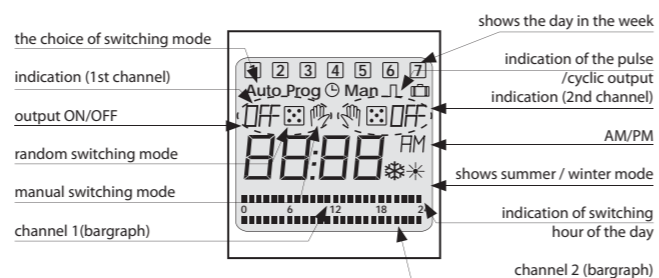

Connection

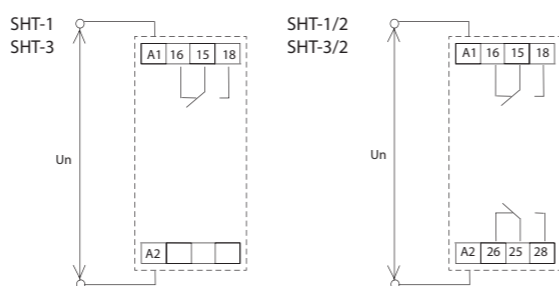

Symbol

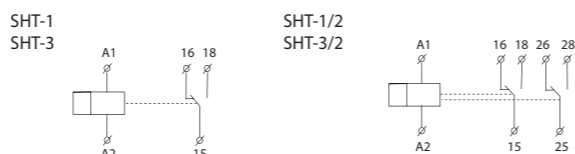

EAN code
 SHT-4: 8595188144759

Technical parameters	SHT-4
Power supply terminals:	A1 - A2
Supply voltage:	AC 230 V / 50 - 60 Hz
Input power:	AC max. 14 VA / 2 W
Supply voltage tolerance:	-15 %; +10 %
Real time back-up:	yes
Transition to summer /winter time:	automatic
Output	
Number of contacts:	2x changeover / SPDT (AgSnO ₂)
Rated current:	16 A / AC1
Switching power:	4000 VA / AC1, 384 W / DC
Peak current:	30 A / < 3 s
Switching voltage:	250 V AC1 / 24 V DC
Min. DC switching power:	500 mW
Mechanical service life:	> 3x10 ⁷
Electrical service life (AC1):	> 0.7x10 ⁵
Timing circuit	
Real time reserve:	up to 3 years
Accuracy of operation:	max. ±1 s per day, at 23°C (73 °F)
Minimum triggering interval:	1 minute
Program data storage period:	10 years at minimum
Programming circuit	
Number of memory locations:	100
Program:	daily, yearly (until 2099)
Data display:	LCD display, backlight
Other information	
Operating temperature:	-20.. +55 °C (-4 °F to 131 °F)
Storage temperature:	-30.. +70 °C (-22 °F to 158 °F)
Electrical strength:	4 kV (power supply - output)
Operating position:	any
Mounting:	DIN rail EN 60715
Protection degree:	IP 10 terminals, IP 40 from front panel
Overvoltage category:	III.
Polution degree:	2
Max. cable size (mm ²):	max. 2x 2.5, max. 1x 4 with sleeve max. 1x 2.5, max. 2x 1.5 (AWG 12)
Dimensions:	90 x 35.6 x 64 mm (3.5" x 1.4" x 2.5")
Weight:	133 g (4.69 oz.)
Standards:	EN 61812-1, EN 61010-1

Plug-in module



Type of backup battery: CR 2032 (3V)

- used for controlling the lighting (billboards, advertisements, shop windows, etc.) with no light sensor required.
- function:
 - by entering the geographic coordinates, the lighting can be switched on/off by sunrise and sunset
 - the preset coordinates for European cities, with optional manual adjustment of the geographical coordinates
 - during programming, 120 minutes may be added to the time of sunrise and sunset
 - selection of ON/OFF functions at sunrise or sunset
 - astro-clock with adjustable interruption
 - operating hours counter for each channel
 - timer - switching on the basis of real-time.
- two-channel design, where each channel is programmable independently of the other.
- automatic switching between winter and summer time.
- sealable transparent cover on the front panel.
- data and time backup using the battery.
- battery life - up to 3 years.
- easy replacement of the backup battery through the plug-in module, no disassembling is required.
- supply voltage: AC 230 V.
- 2-MODULE, DIN rail mounting.

Description

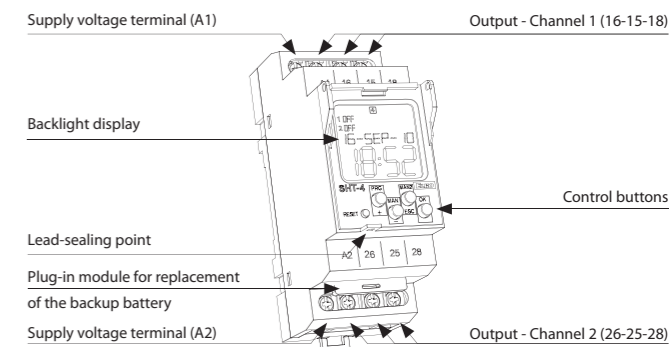

Description of items displayed on the screen

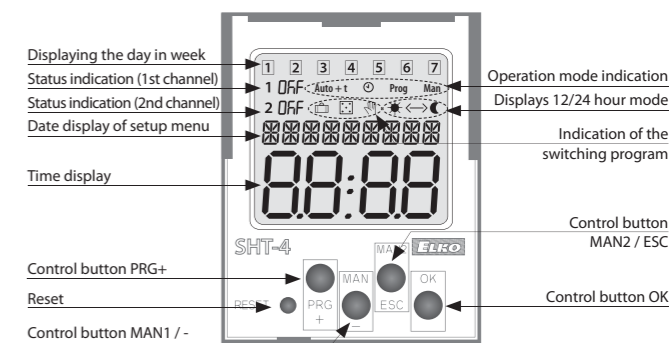

Wiring

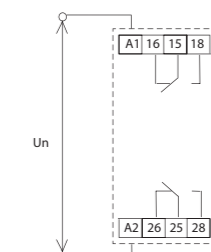

Symbol

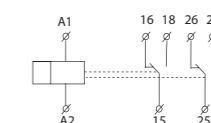



EAN code
SHT-6: 8595188148382
DCFR-1: 8595188148412

Technical parameters	SHT-6
Terminals supply:	A1 - A2
Voltage supply:	AC 230 V / 50 - 60 Hz
Tolerance of voltage supply:	-15 %; +10 %
Output	
Number of contacts:	1 x changeover (AgSnO ₂)
Rated current:	16 A / AC1
Switching capacity:	4000 VA / AC1, 384 W / DC
Peak current:	30 A / < 3 s
Max. switching voltage:	250 V AC1 / 24 V DC
Minimum switching capacity DC:	500 mW
Mechanical life:	> 3x10 ⁷
Electrical life (AC1):	> 0.7x10 ⁵
Time circuit	
Backup real. time:	up to 3 years
Running accuracy	
- without DCF receiver:	max. ±1 s per day with 23°C (73 °F)
Minimum switching interval:	1 min
Data retention programs:	min. 10 years
Program circuit	
Number of memory locations:	100
program:	daily, yearly (till year 2099)
Displayed data:	LCD display with backlight
Other information	
Working temperature:	-10.. +55 °C (14 to 131 °F)
Storage temperature:	-30.. +70 °C (-22 °F to 158 °F)
Dielectric strength:	4 kV (output supply)
Operating position:	any
Mounting:	DIN rail EN 60715
Protection:	IP 10 terminals, IP 40 from the front panel
Over voltage category:	III.
Degree of pollution:	2
Max. cable size (mm ²):	max. 2x 2.5, max. 1x 4 with sleeve max. 1x 2.5, max. 2x 1.5 (AWG 12)
Dimensions:	90 x 35.6 x 64 mm (3.5" x 1.4" x 2.5")
Weight:	121 g (4.27 oz.) (without battery)
Standards:	EN 61812-1, EN 61010-1

Plug-in module

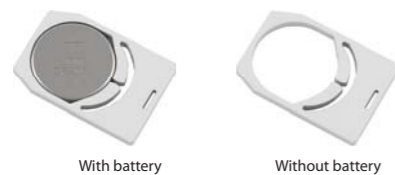

Type of backup battery: CR 2032 (3V)

- Used for controlling appliances depending on real time, that is synchronized by a DCF 77 signal, thanks to the automatic time settings (with DCF 77 signal) it eliminates inaccuracies and errors by time running.
- 1 channel design with external DCF receiver.
- automatic switching between winter/summer time.
- sealable cover of the front panel.
- 100 memory places.
- backlit LCD display.
- switching according to the program: auto / manual / random / holiday program.
- Function of the operating hours counter.
- backing up data and time using the battery.
- reserve battery for up to 3 years.
- Easy replacement for the backup battery with plugging module without dismantling the device.
- Power supply: AC 230 V.
- 2-MODULE, mounting on DIN rail.

Description

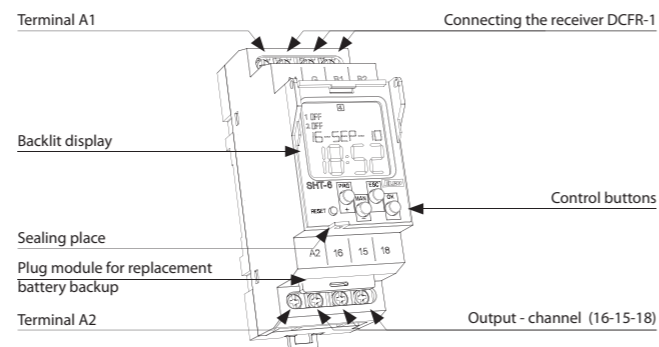

Description of the displayed elements on the screen

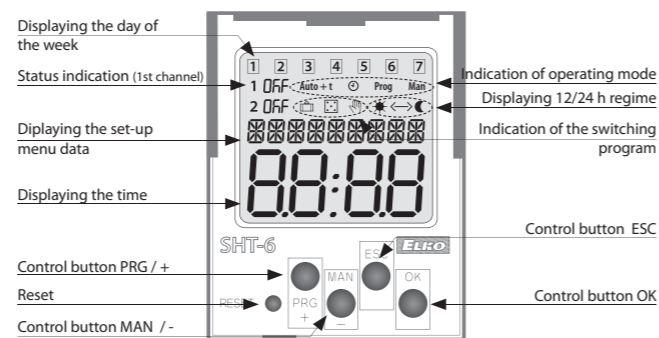

Connection

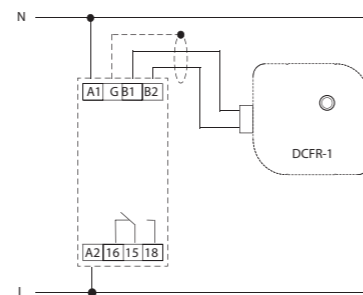

Symbol

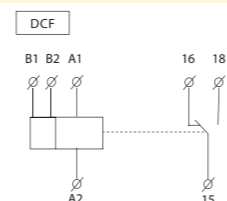

EAN code
DCFR-1: 8595188148412

Technical parameters	DCFR-1
Connection:	2 conductors
Max. cross-connection conductors:	2.5 mm ²
Max voltage on the wires:	10 V
Indication Function:	red LED
Other information	
Storage temperature:	-30.. +70 °C (-22 to 158 °F)
Protection:	IP65
Dimension:	98 x 62 x 34 mm (39.3 x 2.4 x 1.3")
Weight:	110 g (3.88 oz)
Operating position:	perpendicular to the direction of reception
The reception area:	about 1500 km from Frankfurt / Main

Description

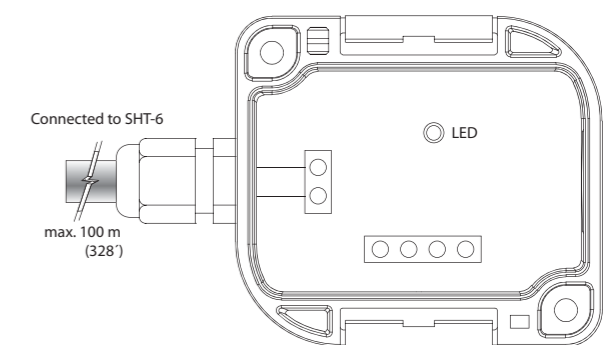

Working position - options

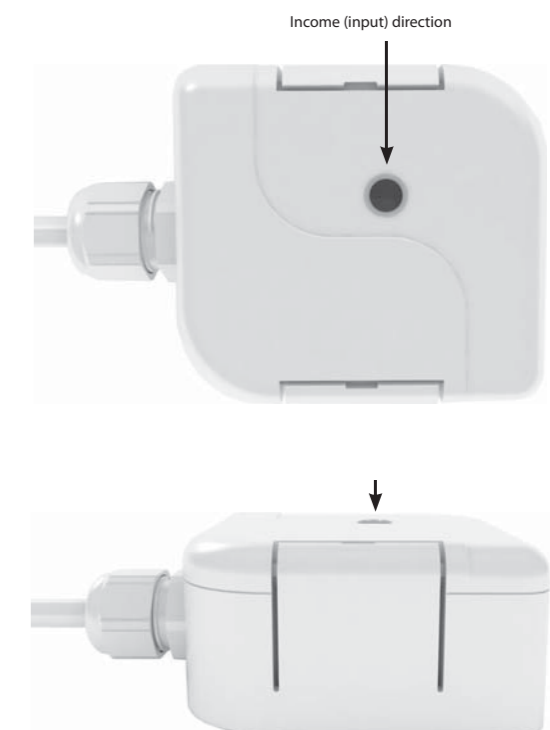

- Universal DCF module, which is designed for controlling the SHT-6 timer, and other devices.
- outdoor applications (IP65 protection).
- Two-wire connection - not polarity sensitive!
- Length of connecting cable is up to 100 m (328').
- visual indication of proper function module.



EAN code
 SMR-K / 230 V: 8595188145176
 SMR-T / 230 V: 8595188129107
 SMR-H / 230 V: 8595188129114
 SMR-B / 230 V: 8595188135566

Technical parameters	SMR-K	SMR-T	SMR-H	SMR-B
Number of functions:	9			10
Connection:	3-wire, without neutral		4-wire, with neutral	
Voltage range:	AC 230 V / 50 - 60 Hz			
Power input (no operation/make):	0.8 / 3 VA		max. 1 / 1 VA	
Supply voltage tolerance:	-15 %; +10 %			
Time ranges:	0.1 s - 10 days			
Time setting:	via rotaty switch			
Time deviation:	10 % - mechanical setting			
Repeat accuracy:	2 % - set value stability			
Temperature coefficient:	0.1 % / °C, at = 20 °C (0.1 % / °F, at = 68°F)			
Output				
Number of contacts:	1 x triac			1x NO-SPST (AgSnO ₂)
Resistive load:	10-160 VA	0-200 VA	16 A 125/250 V AC1	
Inductive load:	10-100 VA	0-100 VA	8 A 250 V AC (cos φ > 0.4)	
Control				
Control voltage:	AC 230 V AC			230 V, UNI-5-250 V AC/DC
Control current:	25 µA	3 mA		
Impulse length:	min. 50 ms / max. unlimited			
Glow tubes connctions:	x	Yes		
Max. amount of glow lamps connected to controlling input:	230 V - max. amount 50 pcs (measured with glow lamp 0.68 mA/230 V AC)			
Other information				
Operating temperature:	0.. +50 °C (+32.. +122 °F)			
Operating position:	any			
Mounting:	free at connecting wires			
Protection degree*:	IP 30 in standard conditions			
Overvoltage category:	III.			
Pollution degree:	2			
Fuse:	F 1 A / 250 V			x
Connection wires (cross-section / lenght):	3x CY, 0.75 mm ² (AWG 18) 90 mm (3.5")	4x sol. wir., 0.75 mm ² (AWG 18) 90 mm (3.5")	2x CY, 0.75mm ² (AWG 18), 2x CY, 2.5 mm ² (AWG 10), 90 mm	
Glow-lamps in control button:	x	max. 10	max. 20	
Dimensions:	49 x 49 x 13 mm			49x49x21 mm
Weight:	26 g	26 g	27 g	53 g
Standards:	EN 61812-1, EN 61010-1			

* for more information see page 38

- Multifunction relay designed for installation into a wiring box or under wall-switch in an existing electrical installation.
- Advantageous and fast solution for exchanging standard wall-switch for a switch controlled by time or for an impulse relay controlled by a button.
- More information about type and size of load for these products can be found on page 123.
- **SMR-K**
 - 3-wire connection, works without the connection of a neutral conductor
 - power output: 10-160 VA
 - for flawless function of the product is necessary the presence of a load R, L or C between input S and neutral wire
- **SMR-T**
 - 3-wire connection, works without the connection of a neutral conductor
 - power output: 10 - 160 VA
 - between input S and neutral wire is possible connect any load R, L, or C - that is not necessary (unlike SMR-K)
- **SMR-H**
 - 4-wire connection
 - power output: 0 - 200 VA
 - 10 functions
 - output contact 1x 16 A / 4000 VA, 250 V AC1
 - enables switching of fluorescent lights and also energy saving lights
 - suitable for switching loads greater than SMR-K, SMR-T, SMR-H, for example pulse relay, stair automatic switch, switching of ladder radiators in bathrooms
 - independent galvanically separated input AC/DC 5 - 250 V, for example for control from a security system
- **SMR-B**
 - 4-wire connection
 - 10 functions
 - output contact 1x 16 A / 4000 VA, 250 V AC1
 - enables switching of fluorescent lights and also energy saving lights
 - suitable for switching loads greater than SMR-K, SMR-T, SMR-H, for example pulse relay, stair automatic switch, switching of ladder radiators in bathrooms
 - independent galvanically separated input AC/DC 5 - 250 V, for example for control from a security system

Description

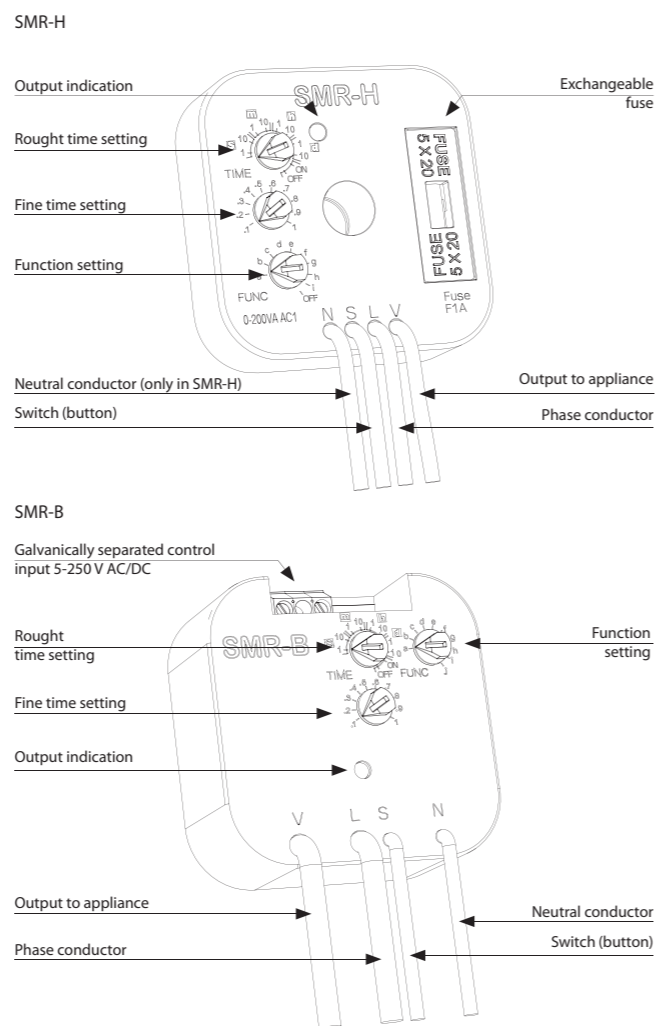

Function

Function a - delay on entering edge
 output times when it is switched. Each following pressing (max. 5x) increases time. Long pressing swithes output off



Function f - delay on
 delay on after switch is switched on until it is switched off



Function b - delay on downward edge
 output times after button is swithed off, switches immediately



Function g - impulse relay
 switches on by a press, another pressing switches the output off. The length of pressing doesn't matter, it is possible to set reaction delay by a potentiometer and thus eliminate rebound of a button



Function c - delay on downward edge
 after switching off output switches on and times.



Function h - impulse relay with delay
 one press switches on, another one switches the output off in case it is done before the end of timing



Function d - cyler - flasher impulsem
 output cycles in regular interval, cyler starts with an impulse



Function i - cyler starting with pause
 output cycles in regular intervals, cyler starts with a pause



Function e - puls shift
 delay on after the switch is switched on and delay on after it is switched off



Function j* - cyler starting with gap
 delay ON until switched off until it is de-energized or a switch is pressed again.
 Note.: *- Function j is valid only for SMR-B

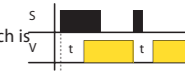

Connection SMR-K, SMR-T, SMR-H, SMR-B

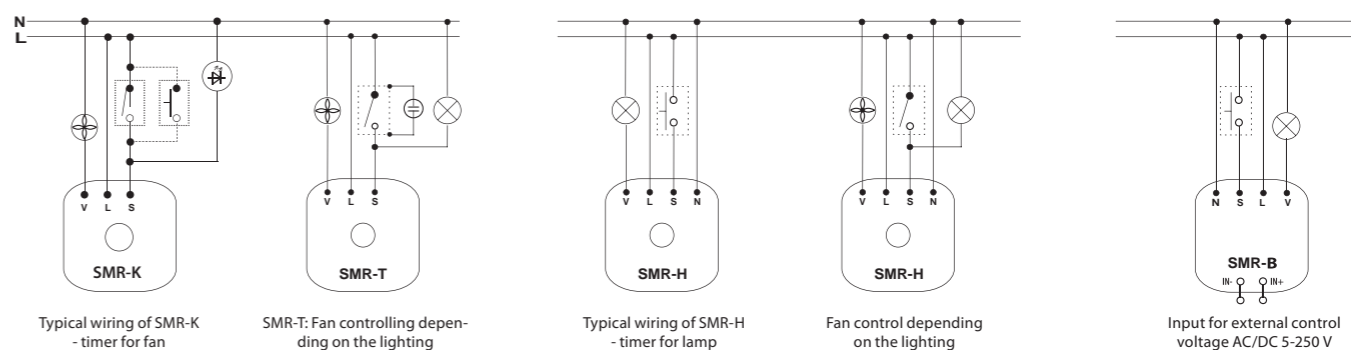

Note: SMR-K, SMR-T, SMR-H are not intended for switching capacity load (energy saving bulbs and LED lights with capacity power etc.), these products are only intended for switching resistive and inductive loads (incandescent bulbs, fans, etc.). SMR-B with relay output is intended to other types of load. Using this output it is possible to switch the load of R, L or C-values listed in the load table. Between inputs S and neutral wire is possible to connect any load of R, L or C, however this is not (unlike the SMR-K) condition.

Example of connection SMR-T

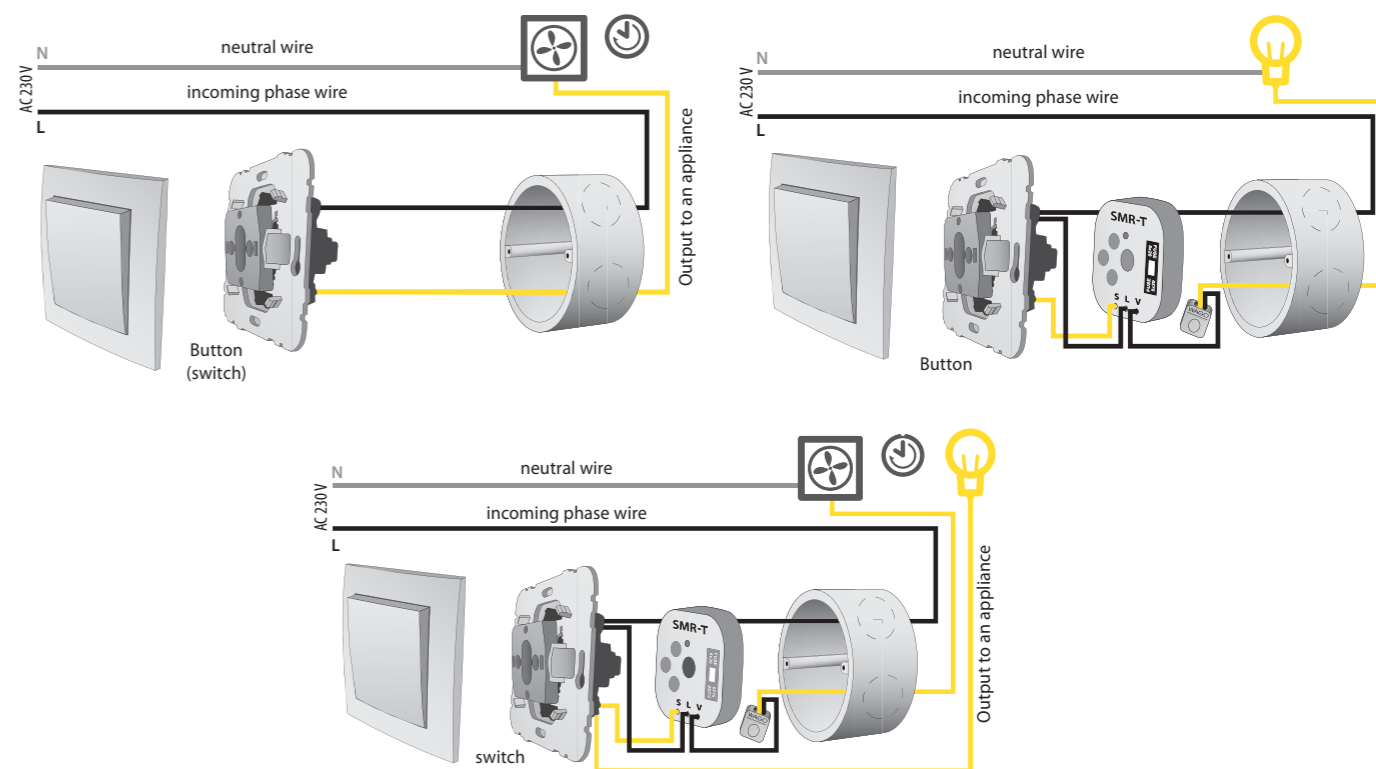



EAN code
CRM-42/230 V: 8595188136693
CRM-42F/230 V: 8595188146883

Technical parameters	CRM-42	CRM-42F
Function:	delay OFF responsive to control contact switch on	
Supply terminals:	A1 - A2	
Voltage range:	AC 230 V / 50 - 60 Hz	
Burden:	AC max. 12 VA / 1.8 W	
Supply voltage tolerance:	-15 %; +10 %	
Supply indication:	green LED	
Time ranges:	0.5 - 10 min	
Time setting:	potentiometer	
Time deviation:	5 % - mechanical setting	
Repeat accuracy:	5 % - set value stability	
Temperature coefficient:	0.05 % / °C, at = 20 °C (0.05 % / °F, at = 68 °F)	
Output		
Number of contacts:	1x NO - SPST (AgSnO ₂), switches potential A1	
Current rating:	16 A / AC1	
Breaking capacity:	4000 VA / AC1, 384 W / DC	
Inrush current:	30 A / < 3 s	
Switching voltage:	250 V AC1 / 24 V DC	
Min. breaking capacity DC:	500 mW	
Output indication:	red LED	
Mechanical life:	3x10 ⁷	
Electrical life (AC1):	0.7x10 ⁵	
Electrical life (AC5b):	8x10 ⁴ (bulbs 1000 W) *	
Control		
Control voltage:	AC 230 V	
Input Burden:	AC 0.53 VA	
Glow tubes connections:	Yes	
Max. amount of glow lamps connected to controlling input:	230 V - max. amount 50 pcs (measured with glow lamp 0.68 mA / 230 V AC)	
Control terminals:	A1-S or A2-S	
Impulse length:	min. 50 ms / max. unlimited	
Reset time:	max. 150 ms	
Other information		
Operating temperature:	-20 °C to +55 °C (-4 °F to 131 °F)	
Storage temperature:	-30 °C to +70 °C (-22 °F to 158 °F)	
Operating position:	any	
Mounting:	DIN rail EN 60715	
Protection degree:	IP 40 from front panel / IP 10 terminals	
Overvoltage category:	III.	
Pollution degree:	2	
Max. cable size (mm ²):	solid wire max. 2x 2.5 or 1x 4, with sleeve max. 1x 2.5 or 2x 1.5, (AWG 12)	
Dimensions:	90 x 17.6 x 64 mm (3.5" x 0.7" x 2.5")	
Weight:	65 g (2.3 oz.)	
Standards:	EN 60669-2-3, EN 61010-1	

* For bigger bulb loads and frequent switching is recommended to intensify the contact relay with power contactor e.g. VSXXX

- Intelligent staircase switch, the same use as CRM-4, but with enlarged possibility of control in mode „PROG“, it is possible to select time of delayed OFF by number of button pressing. Each pressing multiplies time set by potentiometer, it means that in case you set time to 5 min and press the button 3 times, then the output is automatically prolonged to 15 min. Output can be also switched off before time (reset) by long pressing of button (longer than 2 sec).
- Output relay contact 16 A/AC1 with inrush current up to 80 A enables switching of el. bulbs and also fluorescent lights.
- Operating system switch:
 - ON - output is constantly ON (service mode).
 - AUTO - timing according to adjusting by potentiometer in range 30 s - 10 min.
 - PROG - timing with time prolongation option by number button pressing.
- Timing (in mode AUTO and PROG) is possible to be stopped by long pressing of the button (> 2 s).
- Voltage range: AC 230 V, clamp terminals.
- Output indication: multif. red LED, flashing at certain states
- 3-wire or 4-wire connection (it is possible to control input S by potential A1 or A2).
- CRM-42:** Warning before switch OFF- output doubleflash 40 and 30 sec before switch OFF.
- CRM-42F:** Staircase switch without warning flashes especially suited for use with energy-saving lamps, where frequent flashing may cause damage to the light source.
- 1- MODULE, DIN rail mounting.

Description

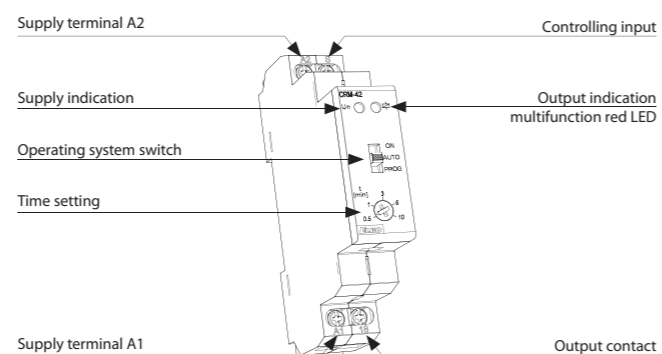

Connection

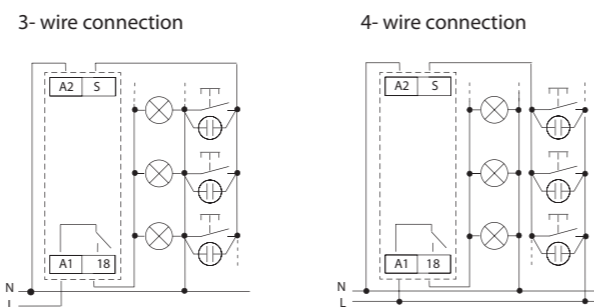

Symbol

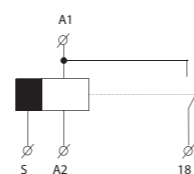

Function

MODE ON

- the output is permanently closed in ON position. Control input is blocked.

MODE AUTO

- by pressing a control button in function AUTO the output closes and after the set time period the output opens.

CRM-42: Warning before switch OFF- output doubleflash 40 and 30 sec before switch OFF*

CRM-42F: without flashing

MODE PROG (the illumination time is defined by number of button pressing)

- in function program the switched time is a sum of each time set by pressing the button. By pressing >2s the output opens.

CRM-42: Warning before switch OFF- output doubleflash 40 and 30 sec before switch OFF*

CRM-42F: without flashing

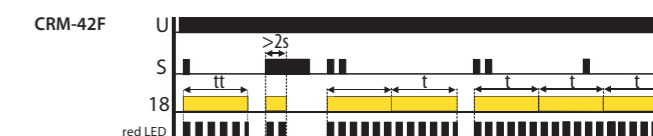
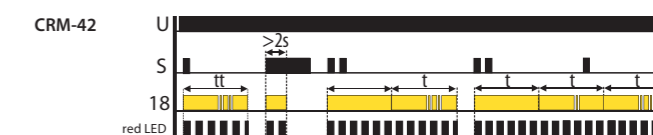
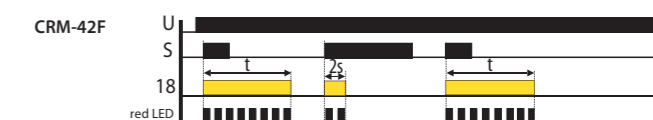
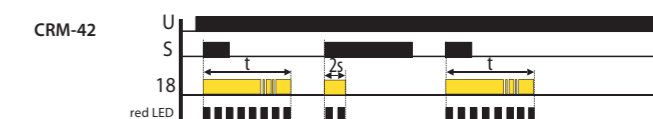
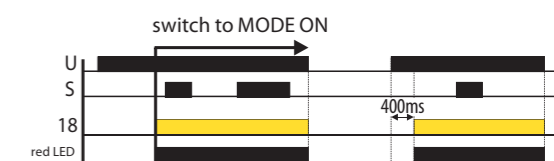

* If the total set time is less than 1 min, there is no flashing according to the graph of the function.



EAN code
CRM-4 / 230 V: 8595188115605

Technical parameters		CRM-4
Function:	delay off reacting to control contact switching	
Supply terminals:	A1 - A2	
Voltage range:	AC 230 V / 50 - 60 Hz	
Burden:	AC max. 12 VA / 1.8 W	
Supply voltage tolerance:	-15 %; +10 %	
Supply indication:	green LED	
Time ranges:	0.5 - 10 min	
Time setting:	potentiometer	
Time deviation:	10 % - mechanical setting	
Repeat accuracy:	5 % - set value stability	
Temperature coefficient:	0.05 % / °C, at = 20 °C (0.05 % / °F, at = 68 °F)	
Output		
Number of contacts:	1x changeover / SPDT (AgSnO ₂)	
Current rating:	16 A / AC1	
Breaking capacity:	4000 VA / AC1, 384 W / DC	
Inrush current:	30 A / < 3 s	
Switching voltage:	250 V AC1 / 24 V DC	
Min. breaking capacity DC:	500 mW	
Output indication:	red LED	
Mechanical life:	3x10 ⁷	
Electrical life (AC1):	0.7x10 ⁵	
Control		
Control voltage:	AC 230 V	
Power on input:	AC 0.53 VA	
Load between S-A2:	Yes	
Control terminals:	A1-S	
Glow tubes connections:	Yes	
Max. amount of glow lamps connected to controlling input:	max. amount 35 pcs (measured with glow lamp 0.68 mA / 230 V AC)	
Impulse length:	min. 25 ms / max. unlimited	
Reset time:	max. 150 ms	
Other information		
Operating temperature:	-20 °C to +55 °C (-4 °F to 131 °F)	
Storage temperature:	-30 °C to +70 °C (-22 °F to 158 °F)	
Electrical strength:	4 kV (supply - output)	
Operating position:	any	
Mounting:	DIN rail EN 60715	
Protection degree:	IP 40 from front panel / IP 20 terminals	
Overtvoltage category:	III.	
Pollution degree:	2	
Max. cable size (mm ²):	solid wire max. 1x 2.5 or 2x 1.5 / with sleeve max. 1x 2.5 (AWG 12)	
Dimensions:	90 x 17.6 x 64 mm (3.5" x 0.7" x 2.5")	
Weight:	62 g (2.2 oz.)	
Standards:	EN 60669-2-3, EN 61010-1	

- Used for delayed switching of lights in the corridors, entrances, stairways, halls or for delayed finish of fans (WC, bathroom, etc.).
- It is controlled by a button or by several buttons from more places (connected in parallel), buttons can be equipped by glow lamps (max. 20 pcs of glow lamps).
- Output relay contact 16 A / AC1 with surge current up to 80 A enables switching of el. bulbs and fluorescent lamps.
- Operating system switch:
 - AUTO - normal function according to set time.
 - OFF - permanently OFF (e.g. when changing bulbs).
 - ON - permanently ON (e.g. while cleaning, servicing).
- Time range: 0.5 - 10 min.
- Time setting by potentiometer.
- Supply voltage : AC 230 V.
- Protection against button blocking (e.g. a match inserted in a button).
- 1- MODULE, DIN rail mounting.

Description

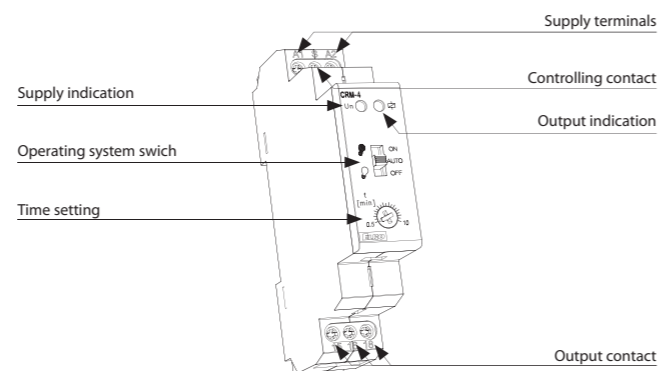

Circuit connection

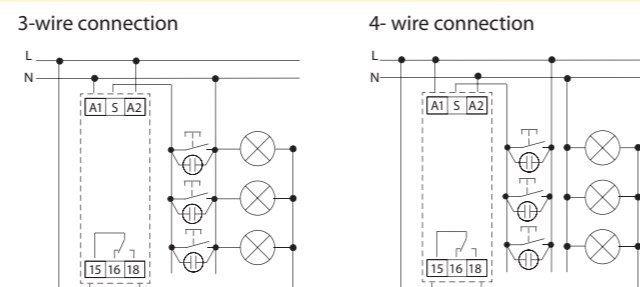

Symbol

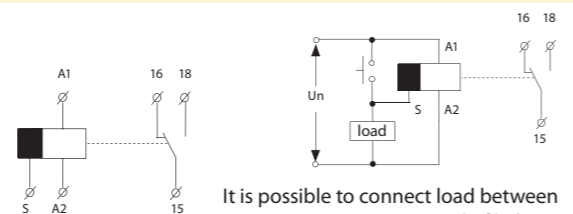

It is possible to connect load between S-A2 (e.g. contactor, control of light or any other device), without disturbing a correct function of relay (load is energized while the switch is ON).

Function

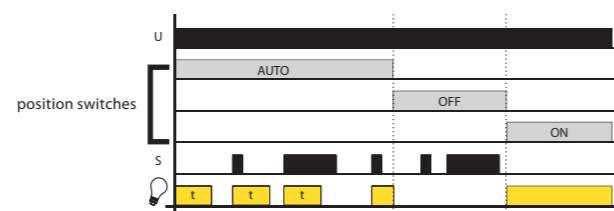

VS(B,K)

 VS116B/230 Supply voltage: AC 230 V Output contact: 1x changeover/ SPDT 16 A.	 VS116K Supply voltage: AC 230 V and AC/DC 24 V Output contact: 1x changeover/ SPDT 16 A.	 VS308K Supply voltage: AC 230 V and AC/DC 24 V Output contacts: 3x changeover/ TPDT 8 A.	 VS316/24 Supply voltage: AC/DC 24 V Output contacts: 3x changeover/TPDT 16 A, possibility to be connected into 3-phase circuit.	 VS316/230 Supply voltage: AC 230 V Output contacts: 3x changeover/ TPDT 16 A, possibility to be connected into 3-phase circuit.
--	---	---	--	--

VS(U)

 VS116U Supply voltage: AC/DC 12-240 V Output contact: 1x changeover/SPDT 16 A.	 VS308U Supply voltage: AC/DC 12-240 V Output contacts: 3x changeover/ TPDT 8 A.
---	--

782L

 782L Power relays plug-in Output contacts: 4 x changeover contact/ SPDT 6 A. Plug-in type.	 ES-15/4N - socket Max. voltage: 12 A Weight: 59 g Mounting to DIN rail Intended for 4-contact relay.
--	---

750L

 750L Power relays plug-in Output contacts: 3 x changeover contact / SPDT 10 A. Plug-in type.	 ES-11- socket Max. current: 10 A Weight: 60 g Mounting to DIN rail Intended for 3-contact relay.
--	--

Overview table

Type	Design	Coil voltage	Output contact	Other features			Designation	Page of catalogue
				LED signal light	RC unit	Paralel diode		
VS116B/230	MINI	AC 230 V/50-60 Hz	1x16 A changeover/ SPDT	●	x	x	VS116/B230 MINI, with installation into junction box or ceiling that allows control of lights, shades or awnings drives	32
VS116K	1M-DIN	AC 230 and AC/DC 24 V	1x16 A changeover/ SPDT	●	●	●	as a separation relay (4kV), direct switching of appliances up to 4000 VA (e.g. heaters), well visible signalization, noiseless	32
VS116U	1M-DIN	AC/DC 12..240 V	1x16 A changeover/ SPDT	●	●	●	as VS116K, but multivoltage supply coil	32
VS308K	1M-DIN	AC 230 and AC/DC 24 V	3x 8 A changeover/ TPDT	●	●	●	a "multiplication" of contacts, 3x changeover contact/ 3PDT only in 1-MODULE, well visible signalization, noiseless	32
VS308U	1M-DIN	AC/DC 12..240 V	3x 8 A changeover/ TPDT	●	●	●	as VS308K, but multivoltage supply coil	32
VS316/24	1M-DIN	AC/DC 24 V	3x16 A changeover/ TPDT	●	●	●	3x changeover contact in 1-MODULE, possibility of "multiplication" of contacts and in the same time possibility of switching high output, possibility of 3 phase switching	32
VS316/230	1M-DIN	AC 230 V	3x16 A changeover/ TPDT	●	●	●	as VS316/24, but AC 230 V	32
782L	PLUG-IN	AC 6-230 V, DC 6-110 V	4x6 A changeover/ 4PDT	●	x	x	compact small relay for installation into plug relay, basic version equipped by LED indication, detent and testing lever	34
750L	PLUG-IN	AC 6-230 V, DC 6-110 V	3x10 A changeover/ 3PDT	●	x	x	as 782, but into 11-pin round socket, 3x changeover contact / 3PDT 10A/250 V	34

More about contact loadability on page 123



VS116K

VS116B

Type	Current rating	Number of contacts	Design	Supply terminals
VS116K	16 A	1	DIN (1M)	A1 - A2 230 V AC / A1 - A3 24 V AC/DC
VS116U	16 A	1	DIN (1M)	A1 - A2 12- 240 V AC/DC
VS116B/230	16 A	1	BOX (MINI)	L-N 230 V AC
VS308K	8 A	3	DIN (1M)	A1 - A2 230 V AC / A1 - A3 24 V AC/DC
VS308U	8 A	3	DIN (1M)	A1 - A2 12 - 240 V AC/DC
VS316/24	16 A	3	DIN (1M)	A1 - A2 24 V AC/DC
VS316/230	16 A	3	DIN (1M)	A1 - A2 230 V AC

- Power relay used for switching larger load output, strengthen or „multiplying“ contacts of the existing device.
- Relays VS316/24, VS316/230 enable connection to a 3-phase circuit.
- In the design 1-MODULE , DIN rail mounting, output status indicated by high intensity LED with choice of LED color (red, green, yellow, blue or white LED*).
- VS116/B230 MINI, mounting in installation box or ceilings, enabling switching of lights, motors for blinds or awnings.
- For VS116/B230 status of output indicated by LED on front panel of device.

Technical parameters	VS116B/230	VS116K	VS116U	VS308K	VS308U	VS316/24	VS316/230
Supply terminals:	L-N			A1-A2			
Voltage range:	AC 230 V / 50-60 Hz	AC 230 V / 50-60 Hz	AC/DC 12-240 V / 50-60 Hz	AC 230 V / 50-60 Hz	AC/DC 12-240 V / 50-60 Hz	AC/DC 24 V / 50-60 Hz	AC 230 V / 50-60 Hz
Burden:	AC max. 7.5 VA / 1W	AC max. 7.5 VA / 1W	AC 0.7 - 3 VA / DC 0.5 - 1.7 W	AC max. 10.3 VA / 1.1 W	AC 0.7 - 3 VA / DC 0.5 - 1.7 W	1.6 VA / 1.2 W	2.5 VA
Supply terminals:	x	A1-A3	x	A1-A3		x	
Voltage range:	x	AC/DC 24 V (50-60 Hz)	x	AC/DC 24 V (50-60 Hz)		x	
Burden:	x	AC 1 VA / DC 1W	x	AC 1 VA / DC 1W		x	
Supply voltage tolerance:				-15%; +10%			
Output							
Number of contacts:	1x changeover / SPDT (AgSnO ₂)		3x changeover / TPDT (AgNi / Silver Alloy)		3x changeover / TPDT (AgSnO ₂)		
Current rating:	16 A / AC1		8 A / AC1		16 A / AC1		
Breaking capacity:	4000 VA / AC1, 384 W / DC		2000 VA / AC1, 192 W / DC		4000 VA / AC1, 384 W / DC		
Inrush current:	30 A / < 3 s		10 A / < 3 s		30 A / < 3 s		
Switching voltage:	250 V AC1 / 24 V DC						
Min. breaking capacity DC:	500 mW						
Output indication:	red LED	high intensity of LED					
Mechanical life:	3x10 ⁷			1x10 ⁷			
Electrical life (AC1):	0.7x10 ⁵			1x10 ⁵			
Time between switching:	min. 2s			20 ms	50 ms		
Other information							
Operating temperature:	-20.. +55 °C						
Storage temperature:	-30.. +70 °C						
Electrical strength:	4 kV (supply-output)						
Operating position:	any						
Mounting:	free connecting wire	DIN rail EN 60715					
Protection degree:	IP 30	IP 40 from front panel					
Overvoltage category:	III.						
Pollution degree:	2						
Max. cable size (mm ²):	2x 0.75 (AWG18) 3x 2.5 (AWG10)	max. 1x 2.5, max. 2x 1.5 max. 1x 2.5 (AWG 12)					
Dimensions:	49 x 49 x 21 mm		90 x 17.6 x 64 mm				
Weight:	48 g	54 g	58 g	52 g	83 g	90 g	92 g
Standards:	EN 61810-1, EN 61010-1						

Symbol

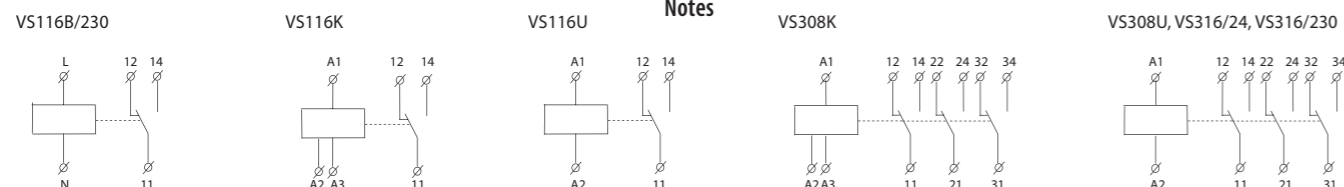

Notes

Description

VS116K, VS116U

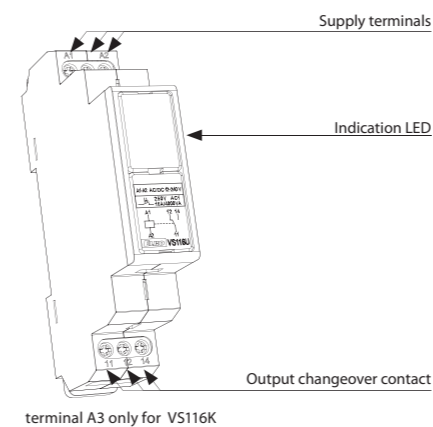

terminal A3 only for VS116K

VS308K, VS308U

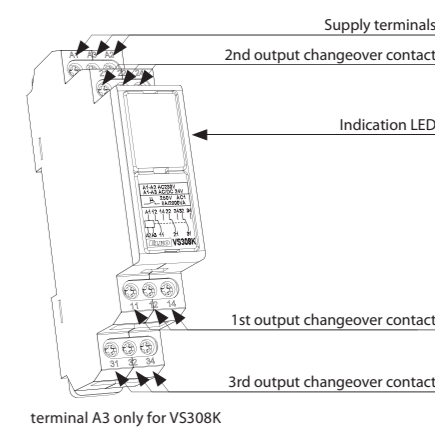

terminal A3 only for VS308K

VS316/24, VS316/230

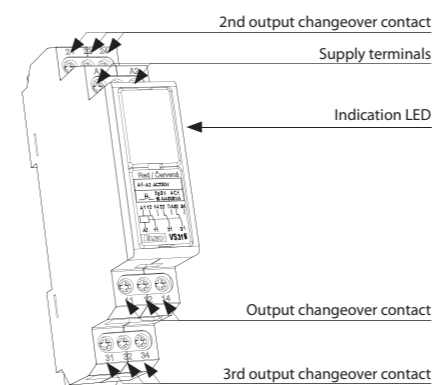

VS116B/230

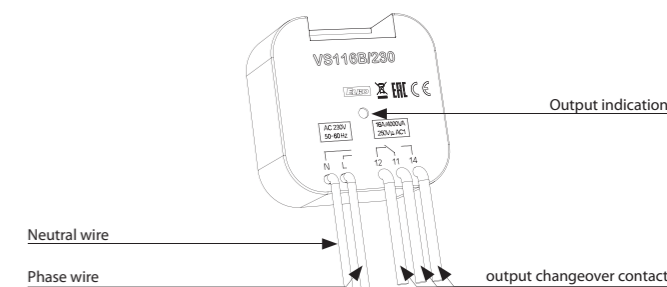

EAN codes

VS116B/230	8595188147545				
VS116K /red	8595188122597	VS308K /red	8595188122696	VS316 /24 red	8595188135771
VS116K /green	8595188122610	VS308K /green	8595188122719	VS316 /24 green	8595188136105
VS116K /yellow	8595188122580	VS308K /yellow	8595188122689	VS316 /24 yellow	8595188136129
VS116K /white	8595188122573	VS308K /white	8595188122672	VS316 /24 white	8595188136099
VS116K /blue	8595188122603	VS308K /blue	8595188122702	VS316 /24 blue	8595188136112
VS116U /red	8595188124607	VS308U /red	8595188130103	VS316 /230 red	8595188135559
VS116U /green	8595188136433	VS308U /green	8595188136440	VS316 /230 green	8595188136075
VS116U /yellow	8595188138499	VS308U /yellow	8595188138529	VS316 /230 yellow	8595188136082
VS116U /white	8595188138482	VS308U /white	8595188138512	VS316 /230 white	8595188136051
VS116U /blue	8595188138475	VS308U / blue	8595188138505	VS316 /230 blue	8595188136068

Max. time of changeover of contact is 10ms.

VS316/24 or VS316/230 enables switching of different phases or 3 phase voltage.

* possibility to choose blue, white and yellow color of LED for power relays line VS in case of minimal order quantity 100 pcs.

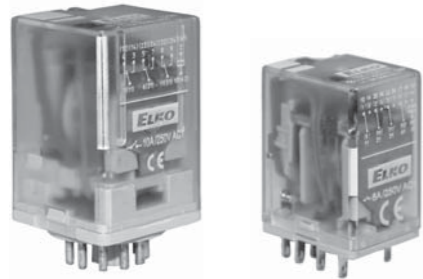

750L

782L

- Used for switching a higher power (load) than the capacity of switched element = amplifier.
- For auxiliary lighting control, signalization, the relay interlockings, boilers, heaters.
- 3x changeover contacts of 10 A (AgNi) for 750L.
- 4x changeover contacts of 6 A (AgNi) for 782L.
- Recommended sockets - ES-11 socket for 750L, ES-15/4N socket for 782L.

Technical parameters	750L	782L
Contacts		
Number of switching contacts:	3	4
Contact material:	AgNi	AgNi
Rated voltage:	AC 250 V/440 V (50 - 60 Hz)	AC 250 V/250 V (50 - 60 Hz)
Rated current:	10 A	6 A
Peak current:	20 A	12 A
Switching capacity (AC1):	10A/250A	6A/250A
Switching capacity (AC3):	370W	125W
Switching capacity (AC15):	(single-phase motor) 3A/120 V/1.5A/240 V	(single-phase motor) 1.5A/120 V/0.75A/240 V
Switching capacity (DC1):	10 A / 24 V DC	6 A / 24 V DC
Switching capacity (DC13):	0.22 A / 120 V 0.1 A/250 V	0.22 A / 120 V 0.1 A/250 V
Minimum switching voltage / current:	5 mA / 5 V	5 mA / 5 V
Coil		
	1.5 W / DC	1.5 W / DC
Rated Voltage (DC):	12, 24, 48, 60, 110, 120, 220 V	5, 6, 12, 24, 60, 80, 125, 220 V
Rated voltage (AC, 50-60 Hz):	12, 24, 48, 60, 115, 120, 230, 240 V	110, 115, 127, 230, 240 V
Rated power (AC / DC):	AC 2.8 VA (50 Hz) / 2.5 VA (60 Hz) / DC 1.5 W	AC 1.6 VA / DC 0.9 W
Tolerance of supply voltage:	-20 / +10 %	-20 / +10 %
Isolating data		
Rated insulation voltage (AC):	2500 V	2500 V
Dielectric strength (AC)		
Coil - contact:	2500 V	2500 V
Contact - contact:	1500 V	1500 V
Isolating resistance at 500 V DC:	10 ⁷ Ω	10 ⁷ Ω
Distance contact - coil		
Air:	≥ 3 mm	≥ 1.6 mm
Surface:	≥ 4.2 mm	≥ 3.2 mm
General information		
Mechanical life:	≥ 2x10 ⁷	1x10 ⁷
Electrical life (AC1):	≥ 2x10 ⁵ 10 A / 250 V AC	≥ 10 ⁵ 6 A / 250 V AC
Max. switching frequency		
At rated load:	1200 cycles / hrs	1200 cycles / hrs
Without load:	12000 cycles / hrs	18000 cycles / hrs
Pick-up time / returning contact:	max. 12 / 10 ms	max. 10 / 8 ms
Working temperature:	-40.. +55 °C (-40 to 131 °F)	-40.. +55 °C (-40 to 131 °F)
Storage temperature:	-40 .. +85 °C (-40 to 185 °F)	-40.. +85 °C (-40 to 185 °F)
Protection:	IP 40 from the front panel	IP 40 from the front panel
Dimensions:	35 x 35 x 54.4 mm	27.5 x 21.2 x 35.6 mm
Weight:	83 g (2.9 oz)	35 g (1.2 oz)
Standards:	EN 60947-4-1, EN 60947-5-1	EN 61810-1, EN 60255-1-00, EN 61810-7

Coil data for 750L

Product Type	Voltage [V]	Resistance [Ω]
AC voltage		
5012	AC 12	18.5
5024	AC 24	75
5048	AC 48	305
5060	AC 60	475
5115	AC 115	1 840
5120	AC 120	1 910
5230	AC 230	7 080
5240	AC 240	7 760
DC voltage		
1012	DC 12	110
1024	DC 24	430
1048	DC 48	1 750
1060	DC 60	2 700
1110	DC 110	9 200
1120	DC 120	11 000
1220	DC 220	37 000

Coil data for 782L

Product Type	Voltage [V]	Resistance[Ω]
AC voltage		
5006	AC 6	9.8
5012	AC 12	39.5
5024	AC 24	158
5042	AC 42	470
5060	AC 60	930
5080	AC 80	1 720
5110	AC 110	3 450
5115	AC 115	3 610
5127	AC 127	4 000
5230	AC 230	16 100
5240	AC 240	16 800
DC voltage		
1005	DC 5	28
1006	DC 6	40
1012	DC 12	160
1024	DC 24	640
1060	DC 60	4 000
1080	DC 80	7 100
1125	DC 125	16 000
1220	DC 220	15 400

Connection

The 750L

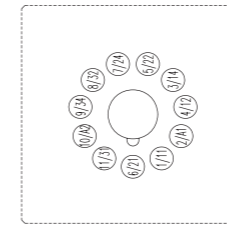

The 782L

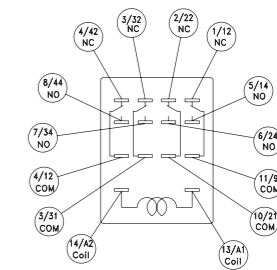

Socket

ES-11 for 750 L

Max. Current: 10A
Weight: 60 g (2.1 oz.)
Mounting on DIN rail
Designed for 3- relay contacts



ES-15/4N - for 782L

Max. Current: 12A
Weight: 59 g (2 oz.)
Mounting on DIN rail
Designed for 4- relay contacts



EAN code

750L/110 V DC	8595188129992	782L/12V AC	8595188119085	ES-15/4N	8595188119245
750L/120 V AC	8595188130028	782L/12V DC	8595188119030	ES-11	8595188129879
750L/12V AC	8595188130011	782L/230 V AC	8595188119115	ES8	8595188136167
750L/12V DC	8595188129978	782L/24V AC	8595188119092	Clip to relay 750L	8595188119283
750L/230 V AC	8595188119221	782L/24V DC	8595188119047	Clip to relay 782L	8595188119276
750L/24V AC	8595188119207	782L/6V DC	8595188129909		
750L/24V DC	8595188125147				
750L/48V DC	8595188129985				

Accessories

To ES-11 socket - for 750L

Clip to relay 750L: 16-1351



To ES-15/4N socket - for 782L

Swivel label - TR1
The LED module, the protective diode and R/C member can be assigned into the slot.







MODULAR



DIM-2
Staircase switch with gradual dimming up/down, level and time of illumination, all values are adjustable.
R = 10 -500 VA
L = 10 -250 VA.



DIM-5
Control by a button/ buttons (connected in parallel), short pressing ON/OFF, long pressing regulates brightness, memory storing.
R = 10 -500 VA
L = 10 -250 VA.



DIM-14
As DIM-5 but dims all types of loads, in-built protection against temperature and current overload, electronic fuse.
R = 500 VA
L = 500 VA
C = 500 VA.



DIM-15
Designated for dimming of: dimmable energy saving fluorescent lamps, LED lamps.
R,L,C, - resistive, inductive and capacitive loads.



LIC-1
Intensity controller for maintaining the constant illumination level.
Dimmable energy saving fluorescent lamps, LED lamps.
R,L,C, - resistive, inductive and capacitive loads.



LIC-2
Serves to dim monochrome LED strips and RGB LED strips with power supply 24 V DC which are current-controlled.



MODULAR



DIM-6
Power dimming to 2kW. Can be controlled by button, external potentiometer, 0-10 V (1-10 V) system iNELS.
R = 2000 VA
L = 2000 VA
C = 2000 VA.



DIM6-3M-P
DIM6-3M-P is a power module expansion unit for DIM-6. It cannot be operated independently.
R = 1000 VA
L = 1000 VA
C = 1000 VA.

MODULAR



DCDA-33M
Dimmer serves to control LED strips, RGB LED strips through bus DALI, CIB or DMX.

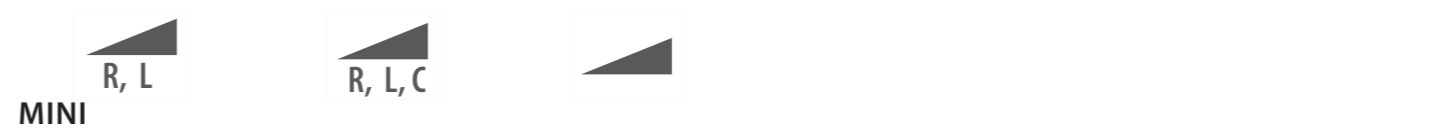

MINI



SMR-S
As DIM-5, but for mounting under a wall-switch into an installation box KU-68 (or the similar), 3 wire connection (without neutral).
R = 10-300 VA
L = 10-150 VA.



SMR-U
As DIM-14, but for mounting under a wall-switch into an installation box KU-68 (or the similar).
R = 1000 VA
L = 1000 VA
C = 1000 VA.



SMR-M
For mounting under a wall-switch into an installation box KU-68 (or similar). Dimmable energy saving fluorescent lamps, LED lamps.
R,L,C, - resistive, inductive and capacitive loads.

Type	Design	Supply voltage	Type of dimmed load					Output unit	Output			Method of phase regulation		Control principal		Designation	Catalogue page
			R	L	C	ESL	LED		Rated load			ON-DIMMER	OFF-DIMMER	DALI, CIB, DMX	0-10 V / 1-10 V		
									R	L	C						
DIM-2	1M-DIN	AC 230 V	●	●	x	x	x	triac	10-500 VA*	10-250 VA	x	●	x	x	x	staircase switch with gradual dim-up/dim-down, level and length of illumination, all values are adjustable	39
DIM-5	1M-DIN	AC 230 V	●	●	x	x	x	triac	10-500 VA*	10-250 VA	x	●	x	x	x	control by button/buttons (connected in parallel), short pressing ON/OFF, long pressing regulated brightness, memory recording	40
DIM-14	1M-DIN	AC 230 V	●	●	●	x	x	2x MOSFET	500 VA*	500 VA*	500 VA*	●	●	x	x	as DIM-5, but dims all types of load, inbuilt protections against thermo and current overload, electronic fuse	41
DIM-15	1M-DIN	AC 230 V	●	●	●	●	●	2x MOSFET	300 VA	300 VA	300 VA	x	x	x	x	designated for dimming of: R, L, C, ESL, LED	44
DIM-6	6M-DIN	AC 230 V	●	●	●	x	x	4x MOSFET	2 000 VA*	2 000 VA*	2 000 VA*	●	●	x	x	for controlled dimming of lights up to 2kW, with a possibility of module extension up to 20kW (el.bulbs and halogen lights, also with ballast type C or L)	42
DIM6-3M-P	3M-DIN	AC 230 V	●	●	●	x	x	2x MOSFET	1 000 VA*	1 000 VA*	1 000 VA*	x	x	x	x	is expanding power modul for controlled dimmer DIM-6	43
SMR-5	BOX	AC 230 V	●	●	x	x	x	triac	10-300 VA*	10-150 VA	x	●	x	x	x	as DIM-5, but for mounting under a wall-switch, into a wiring box, 3 wire connection (without neutral) is expanding power modul for controlled dimmer DIM-6	46
SMR-U	BOX	AC 230 V	●	●	●	x	●	2x MOSFET	500 VA*	500 VA*	500 VA*	●	●	x	x	as DIM-14, but for mounting under a wall-switch, into an installation box	46
SMR-M	BOX	AC 230 V	●	●	●	●	●	2x MOSFET	160 VA	160 VA	160 VA	●	●	x	x	designated for dimming of: R, L, C, ESL, LED	44
LIC-1	1M-DIN	AC 230 V	●	●	●	●	●	2x MOSFET	300 VA*	300 VA*	300 VA*	●	●	x	x	serves to dim all types of load, dimmable LED and energy saving bulbs included	47
LIC-2	1M-DIN	AC 100-250 V	x	x	x	x	x	2x MOSFET	x	x	x	x	x	x	●	control unit for dimmers or electronic ballasts with analog control 0-10 V / 1-10 V	48
DCDA-33M	3M-DIN	24V DC	x	x	x	x	x	x	x	x	x	x	x	●	●	serves to dim monochrome LED strips and RGB LED strips with power supply 12-24 V DC which are current-controlled	49

Note: * - with load over 300 VA is necessary to ensure sufficient cooling

Key to symbols

TYPE OF LOAD (symbols)	bulbs, halogen lamps	low-voltage el.bulbs 12/24V wound transformers	low-voltage el.bulbs 12/24V electronic transformers	ESL dimmable compact fluorescent lamps	LED lamps
	R	L	C	ESL	LED

Demonstrated symbols are informative

Expandatory:

Dimmer with designated load:

- R - resistive
- L - inductive
- C - capacitive

- ESL - energy saving bulbs
- LED - LED bulbs

IPxx protection - under normal conditions: normal conditions are understood as such conditions of operating an electrical device, installation and power supply network for which the entire device is designed, produced and installed. Upon these normal conditions of use and upon normal maintenance, all protective devices must be effective throughout the entire expected service life of the product.

Recommendation for mounting modular dimmers: leave a gap of min. 0.5 module (approx. 9 mm / 0.4") on side of the device to ensure better cooling of the device.



EAN code
DIM-2 /230 V: 8595188112475
DIM-2-1h /230 V: 8595188135740

Technical parameters		DIM-2	
Supply terminals:	A1 - A2		
Voltage range:	AC 230 V / 50 Hz		
Burden:	max. 5 VA		
Supply voltage tolerance:	-15 %; +10 %		
Supply indication:	green LED		
Time setting by:	potentiometers		
Time deviation:	10 % - mechanical setting		
Repeat accuracy:	5 % - set value stability		
Temperature coefficient:	0.01 % / °C, at = 20 °C (0.01 % / °F, at = 68 °F)		
Recovery time:	max. 80 ms		
Controlling T1 (button)			
Terminals:	T1 - A1		
Voltage:	AC 230 V		
Power on control input:	max. 1.5 VA		
Impulse length:	min.100 ms / max. unlimited		
Glow-lamps:	Yes		
Max. amount of glow lamps connected to controlling input:	230 V - max. amount 50 pcs (measured with glow lamp 0.68 mA / 230 V AC)		
Controlling T2 (switch)			
Terminals:	T2 - A1		
Voltage:	AC 230 V		
Power on control input:	0.1 VA		
Impulse length:	min.100 ms / max. unlimited		
Output			
Current rating:	2 A		
Resistance load:	10 - 500 VA		
Inductive load:	10 - 250 VA		
Other information			
Operating temperature:	-20 °C to +55 °C (-4 °F to 131 °F)		
Storage temperature:	-30 °C to +70 °C (-22 °F to 158 °F)		
Operating position:	any		
Mounting:	DIN rail EN 60715		
Protection degree:	IP 40 from front panel / IP 10 terminals		
Overvoltage category:	III.		
Pollution degree:	2		
Max. cable size (mm ²):	solid wire max. 2x 2.5 or 1x 4/ with sleeve max. 1x 2.5 or 2x 1.5 (AWG 12)		
Dimensions:	90 x 17.6 x 64 mm (3.5" x 0.7" x 2.5")		
Weight:	65 g (2.3 oz.)		
Standards:	EN 60669-2-1, EN 61010-1		

Symbol

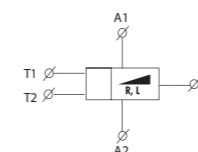

- Designated for dimming el. bulbs, halogen lights and halogen lights with winding transformers.
- Intelligent control of halogen lights, function of gradual switching on and dimming.
- Controlling inputs for push button and switch.
- Values are set by potentiometers on front panel of the product, adjustable:
 - maximum dim-up
 - speed (fluency) of dim-up
 - speed (fluency) of dim-down
 - time for which a light is on with maximum dim-up.
- All time intervals can be adapted according to a request.
- Output without contact: 1x triac.
- Load AC 5b (el. bulbs) 500 W.
- Clamp terminals.
- Parallel connection of controlling pushbuttons is possible.
- Protection against over-temperature inside the product - switches output off + signalizes overheating by LED flashing.
- Note: possibility of start and finish adjustment up on 1 hour, device has description DIM-2 1h.
- 1-MODULE, DIN rail mounting.

Description

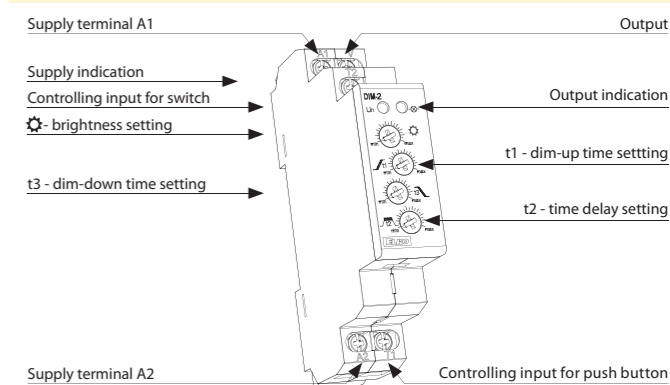

Recommendation for mounting: leave a gap of min. 0.5 module (approx. 9 mm) on side of the device to ensure better cooling of the device.

Connection

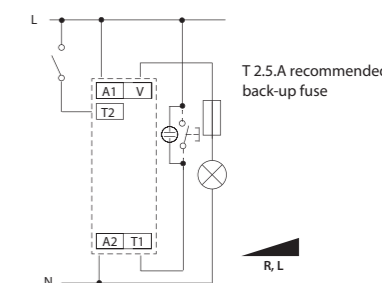

Function

Controlled via input T1(button)

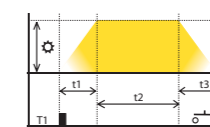

Dim-up delay-down is started by a button. Cycle extension - by re-pressing button (during the cycle).

Controlled via input T2 (switch)

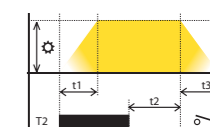

The switch starts the cycle and it stops on max.set brightness. After the switch is off, the cycle will continue until completed.

- Legend:
- ☀ Brightness: 10-100%
 - t1 - Dim-up time: 1-40 s
 - t2 - Time delay: 0s-20min
 - t3 - Dim-down time: 1-40s



EAN code
DIM-5 / 230 V: 8595188115612

Technical parameters	DIM-5
Supply terminals:	A1 - A2
Voltage range:	AC 230 V / 50 Hz
Burden:	max. 5 VA
Supply voltage tolerance:	-15 %; +10 %
Supply indication:	green LED
Controlling	
Control terminals:	T - A1
Control voltage:	AC 230 V
Power control input:	max. 1.5 VA
Impulse length:	min. 80 ms / max. unlimited
Glow-lamps:	Yes
Max. amount of glow lamps connected to controlling input:	230 V - max. amount 50 pcs (measured with glow lamp 0.68 mA / 230 V AC)
Output	
Current rating:	2 A
Resistance load:	10 - 500 VA
Inductive load:	10 - 250 VA
Output indication:	red LED
Other information	
Operating temperature:	-20 °C to +55 °C (-4 °F to 131 °F)
Storage temperature:	-30 °C to +70 °C (-22 °F to 158 °F)
Operating position:	any
Mounting:	DIN rail EN 60715
Protection degree:	IP 40 from front panel / IP 10 terminals
Overvoltage category:	III.
Pollution degree:	2
Max. cable size (mm ²):	solid wire max. 2x 2.5 or 1x 4, with sleeve max. 1x 2.5 or 2x 1.5 (AWG 12)
Dimensions:	90 x 17.6 x 64 mm (3.5" x 0.7" x 2.5")
Weight:	58 g (2 oz.)
Standards:	EN 60669-2-1, EN 61010-1

Recommendation for mounting: leave a gap of min. 0.5 module (approx. 9 mm / 0.4") on side of the device to ensure better cooling of the device.

- Designated for dimming el. bulbs, halogen lights and halogen lights with winding transformers.
- For switching and dimming lights in corridors, stairways... control input for push-buttons (parallel connection possible).
- Short press turns light on/off, longer press (> 0.5 s) provides dim up / dim down.
- When switched off, brightness level is stored in a memory and when ON again it restores last brightness level.
- Voltage range: AC 230 V.
- Contactless output, triac 2 A / 500 VA.
- LED output indication (with any level of brightness).
- Possibility to connect control buttons in parallel.
- 1-MODULE, DIN rail mounting.
- Clamp terminals.
- Protection against over-heating inside the product - switches output off + signalizes overheating by LED flashing.

Description

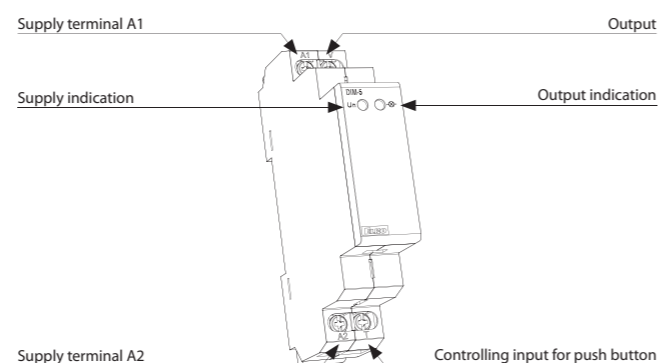

Connection

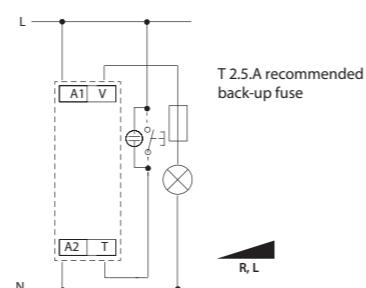

Function

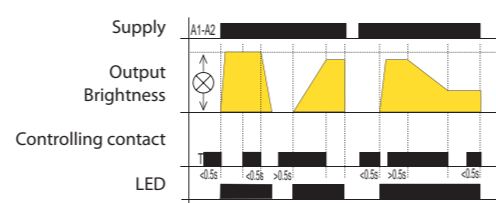

Symbol

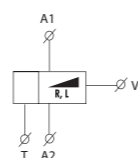

EAN code
DIM-14 / 230 V: 8595188135955

Technical parameters	DIM-14
Supply terminals:	A1 - A2
Voltage range:	AC 230 V / 50 Hz
Burden:	1.3 W
Supply voltage tolerance:	-15 %; +10 %
Dissipated power:	6 VA
Indication output:	green LED
Controlling	
Control terminals:	A1 - T
Control voltage:	AC 230 V
Power control input:	AC 0.3-0.6 VA
Impulse length:	min. 80 ms / max. unlimited
Glow-lamps:	Yes
Max. amount of glow lamps connected to controlling input:	230 V - max. amount 20 pcs (measured with glow lamp 0.68 mA / 230 V AC)
Output	
Contactless:	2 x MOSFET
Current rating:	2 A
Resistance load:	500 VA*
Inductive load:	500 VA*
Capacitive load:	500 VA*
Output state indication:	red LED
Other information	
Operating temperature:	-20 °C to +35 °C (-4 °F to 95 °F)
Storage temperature:	-20 °C to +60 °C (-4 °F to 140 °F)
Operating position:	any
Mounting:	DIN rail EN 60715
Protection degree:	IP 40 from front panel / IP 10 terminals
Overvoltage category:	III.
Pollution degree:	2
Max. cable size (mm ²):	solid wire max. 2x 2.5 or 1x 4, with sleeve max. 1x 2.5 or 2x 1.5 (AWG 12)
Dimensions:	90 x 17.6 x 64 mm (3.5" x 0.7" x 2.5")
Weight:	58 g (2 oz.)
Standards:	EN 60669-2-1, EN 61010-1

* When load is above 300 VA it is necessary to ensure sufficient cooling.

Recommendation for mounting: leave a gap of min. 0.5 module (approx. 9 mm / 0.4") on side of the device to ensure better cooling of the device.

Warning for DIM-14: it is not allowed to connect together loads of inductive and capacitive type in the same time.

- Designed for dimming of incandescent bulbs and halogen lights with wound or electronic transformer.
- For switching and dimming of lights, control inputs for a button.
- Short impulse switches ON/OFF, longer impulse (>0.5s) enables gradual light intensity setting.
- Last intensity level is stored in memory when switched off.
- Voltage range: AC 230 V.
- Output without contacts: 2x MOSFET.
- LED output indicator with any level of brightness possibility of parallel connection of control buttons.
- Resistive, inductive or capacitive load, up to 300 W, for a short term up to 500 W.
- 1-MODULE, DIN rail mounting.
- Electronic overvoltage protection.
- Protection against over-heating inside the device - output off.

Description

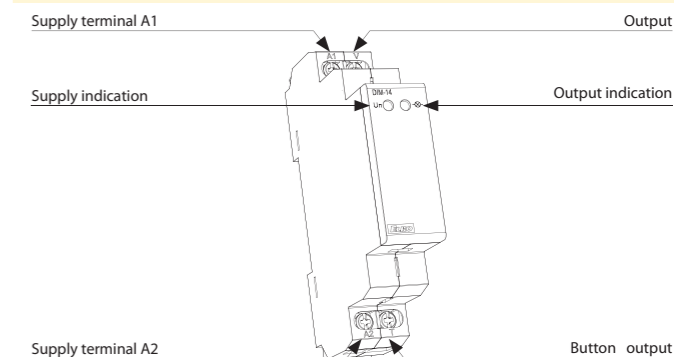

Connection

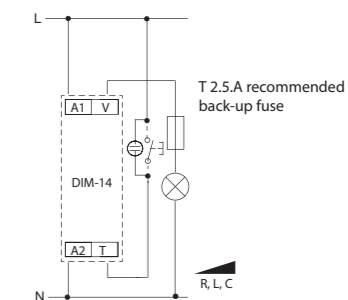

Function

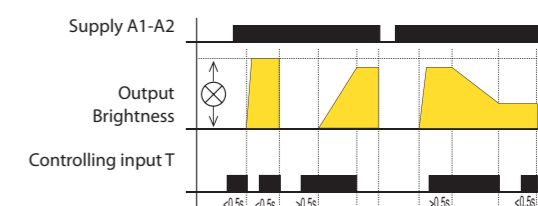

Symbol

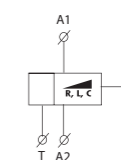



EAN code
DIM-6 / 230 V: 8595188136914

Technical parameters		DIM-6
Supply terminals:		L, N
Supply voltage:		AC 230 V / 50 Hz
Input:		10 VA
Tolerance of voltage range:		-15 %; +10 %
Max. output power:		max. 2 000 VA
Dissipated power:		2.5 % from load
Module extendable:		to 10 000 VA
Galvanic separation of bus and power output:		Yes
Insul. volt. between outputs and inner circuits:		3.75 kV, SELV according to EN 60950
Control - button type		
Control voltage:		AC 12 - 240 V
Control terminals:		S - S, galvanically separated
Power of control input:		AC 0.53VA (AC 230 V), AC 0.025-0.2VA (AC 12-240 V)
Length of control impulse:		min. 25 ms / max. unlimited
Recovery time:		max. 150 ms
Connection of glow lamps:		No
Control 0(1)-10 V		
Control terminals:		0(1)-10 V, GND
Control voltage:		0-10 V or 1-10 V
Min. current of control input:		1 mA
CIB control:		
Control terminals:		CIB+, CIB-
Bus voltage:		27 V DC
Current of control input:		5 mA
Indication of data transmission:		yellow LED
Output		
Contactless:		4 x MOSFET
Current rating:		10 A
Resistive load:		2 000 VA*
Inductive load:		2 000 VA*
Capacitive load:		2 000 VA*
Indication of output state:		yellow LED, according to load type
Other information		
Operating temperature:		-20 °C to +35 °C (-4 °F to 95 °F)
Storing temperature:		-30 °C to +70 °C (-22 °F to 158 °F)
Operating position:		vertical
Mounting:		DIN rail EN 60715
Protection degree:		IP 40 from front panel
Purpose of control device:		operative control device
Construction of control device:		individual control device
Char. of automatic operation:		1.B.E
Heat and fire resistance cat.:		FR-0
Anti-stroke category (immunity):		class 2
Rated impulse voltage:		2.5 kV
Overvoltage category:		III.
Pollution level:		2
Profile of connecting wires (mm ²)		
- output part:		max.1x2.5, max. 2x1.5/ with sleeve max. 1x1.5 (AWG 12)
- control part:		max.1x2.5, max. 2x1.5/ with sleeve max. 1x2.5 (AWG 12)
Dimensions:		90 x 105 x 65 mm (3.5" x 4.1" x 2.6")
Weight:		410 g (14.5 oz.)
Standards:		EN 60669-2-1, EN 61010, EN 55014

- Designed for RLC dimming lights, it is possible to use the device also for switching appliances.
- DIM-6 can be controlled by:
 - button (parallel button connection)
 - external potentiometer
 - analog signal 0-10 V (1-10 V)
 - iNELS BUS system.
- Actuator manages output 230 V AC, controlled by 1 semi-conductor. Maximum output power is 2000 VA.
- power range can be increased up to 10 000 VA by module DIM6-3M-P.
- Electronic overcurrent protection, overvoltage and short-circuit protection.
- Protection against over-heating inside device - switch off output + signalize overheat by flashing red LED.
- 6-MODULE version, DIN rail mounting.

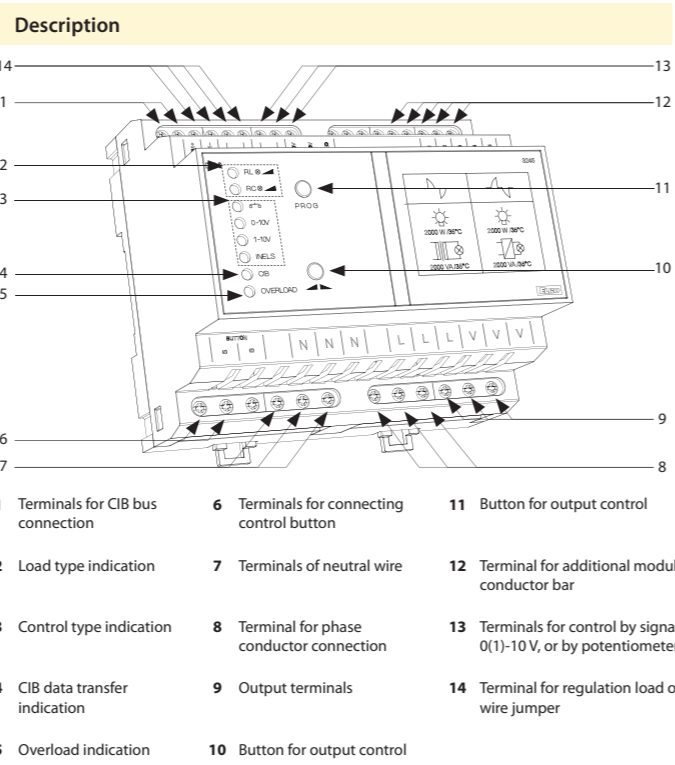

- ### Types of indication LED
- RL - Yellow-indicates configuration of load RL
 - RC - Yellow-indicates configuration of load RC
 - Green-button control mode selected
 - 0-10V - Green - 0-10 V signal control mode selected
 - 1-10V - Green - 1-10 V signal control mode selected
 - iNELS - Green - CIB conductor bar-iNELS control mode selected
 - CIB - Yellow - indicates data transfer communication of CIB bus
 - OVERLOAD - Red - indicates overload, flashing LED signalizes over-heating inside the device, shinning LED signalizes current overload

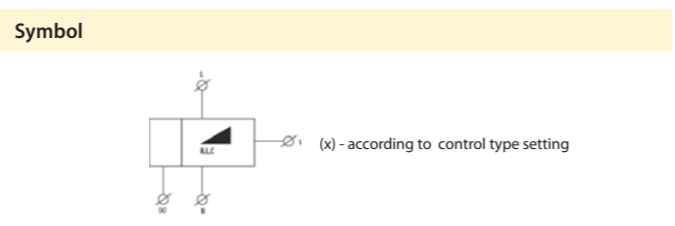

* Warning : it is not allowed to connect inductive and capacitive loads at the same time.



EAN code
DIM6-3M-P: 8595188139106

Technical parameters		DIM-6-3M-P
Load		max. 1 000 VA
Dissipated power:		2.5 % from load
Output		
Contactless:		2 x MOSFET
Current rating:		5 A
Resistive load:		1 000 VA*
Inductive load:		1 000 VA*
Load capacity:		1 000 VA*
Other information		
Operating temperature:		-20 °C to +35 °C (-4 °F to 95 °F)
Storing temperature:		-30 °C to +70 °C (-22 °F to 158 °F)
Operating position:		vertical
Mounting:		DIN rail EN 60715
Protection degree:		IP 40 from front panel
Controlling device purpose:		operating control device
Controlling device construction:		additional control device
Automatic operating char.:		1.B.E
Heat and fire resistance category:		FR-0
Immunity category:		class 2
Rated impuls voltage:		2.5 kV
Overvoltage category:		III.
Pollution level:		2
Profile of connecting wires (mm ²)		
- output part:		max.1x2.5, max. 2x1.5 / with sleeve max. 1x1.5 (AWG 12)
- control part:		max.1x2.5, max. 2x1.5 / with sleeve max. 1x2.5 (AWG 12)
Size:		90 x 52 x 65 mm (3.5" x 2" x 2.6")
Weight:		134 g (4.7 oz.)
Standards:		EN 60669-2-1, EN 61010, EN 55014

* Warning: it is not allowed to connect loads of inductive and capacitive character at the same time.

- Expanding power module only for use in combination with DIM-6.
- DIM6-3M-P provides power increase (of about 1 000 VA) of load connected to DIM-6 (it means: 2 000 VA (DIM-6) + 1 000 VA (DIM6-3M-P) = 3 000 VA).
- DIM-6 can be connected with up to 8 DIM6-3M-P to expand power up to 10 000 VA.
- Attention-device has to be protected by circuit breaker accordant to the load connected to device.
- DIM-6 in installation is cooled by natural air flow. If the natural air flow access is reduced, cooling has to be provided by ventilator. Rated operating temperature is 35 °C / 95 °F.
- If there are several DIM6-3M-P connected to DIM-6, the distance between them has to be min. 2 cm / 0.8".
- Max. length of bus EB is 1 m/ 39.4" and the connection has to be realized by shielded cable.

Device description

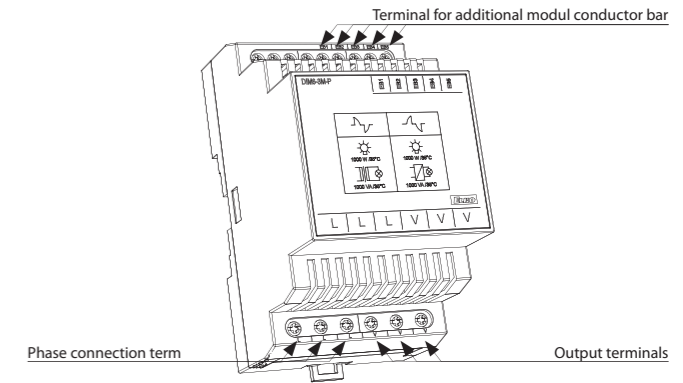

Connection

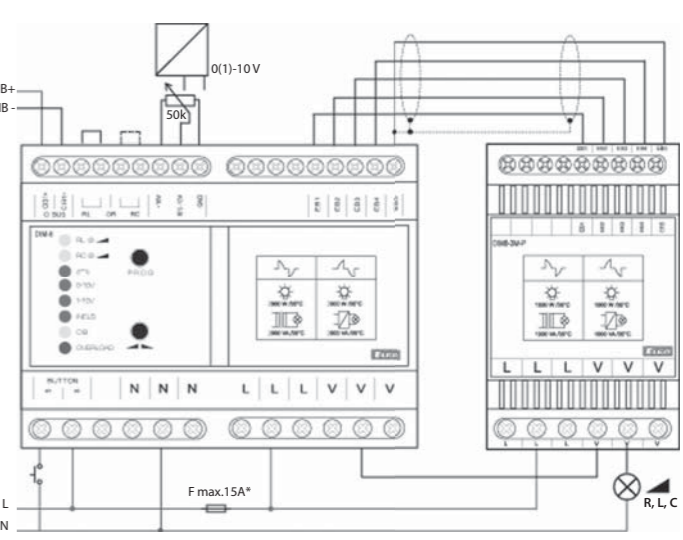

* Potential L on device terminal, has to be protected by circuit breaker accordant to the load connected to device.

* Warning : it is not allowed to connect inductive and capacitive loads at the same time.

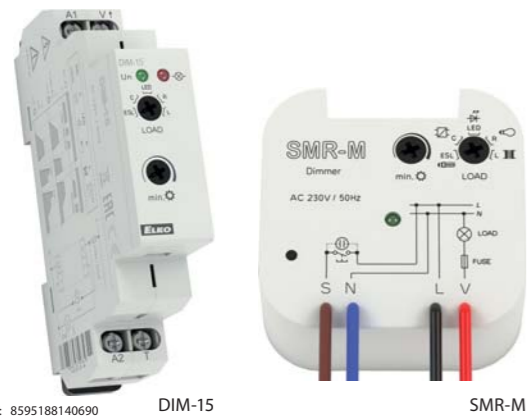

EAN code
DIM-15/230 V: 8595188140690
SMR-M: 8595188143776

Technical parameters	DIM-15	SMR-M
Supply terminals:	A1 - A2	x
Voltage range:	x	4-wire, with neutral
Operating range:	AC 230 V / 50 Hz	
Apparent power:	-15 %; +10 %	
Loss power:	max. 1.5VA	
Dissipated power:	max. 0.7W	
Supply indication:	green LED	
Control		
Control terminals:	A1 - T	x
Control wire:	x	L - S
Control voltage:	AC 230 V	
Control input power:	AC 0.3 - 0.6 VA	
Control impulse lenght:	min. 80 ms / unlimited	
Glow tubes connection:	Yes	
Max. amount of glow lamps connected to controlling input:	max. 15 pcs (measured with glow lamp 0.68 mA / 230 V AC)	max. 10 pcs (measured with glow lamp 0.68 mA / 230 V AC)
Output		
Contactless:	2 x MOSFET	
Load:	300 W (at cos φ = 1)*	160 W (at cos φ = 1)*
Output status indication:	red LED	x
Other information		
Operating temperature:	-20 °C to +35 °C (-4 °F to 95 °F)	
Storing temperature:	-20 °C to +60 °C (-4 °F to 140 °F)	
Operating position:	any	
Mounting:	DIN rail EN 60715	free at connecting wires
Protection degree:	IP 40 from front panel / IP 10 clips	IP 30 in standard conditions**
Overvoltage category:	III.	
Pollution level:	2	
Terminal wire capacity (mm ²):	max. 2x2.5, with sleeve max. 1x2.5, max. 2x1.5 (AWG 12)	x
Connection wires (cross-section / lenght):	x	CY, 0.75 mm ² (AWG 18) / 90 mm (3.5")
Dimensions:	90 x 17.6 x 64 mm	49 x 49 x 21 mm
Weight:	57 g	38 g
Standards:	EN 60669-2-1, EN 61010-1	

* Due to a large number of light source types, the maximum load depends on the internal construction of dimmable light sources and their power factor cos φ. The power factor of dimmable LEDs and ESL bulbs ranges from cos φ = 0.95 to 0.4. An approximate value of maximum load may be obtained by multiplying the load capacity of the dimmer by the power factor of the connected light source.
** for more information see page 38.

- Designed for dimming of:
 - R - bulbs, halogen lamps.
 - L - low-voltage el.bulbs 12/24V wound transformers.
 - C - low-voltage el.bulbs 12/24V electronic transformers.
 - ESL - dimmable compact fluorescent lamps.
 - LED - LED lamps.
 - Enables gradual setting of luminance by push-button (non-detent) or parallel buttons.
 - Returns to last state upon re-energization.
 - Type of light source is set by switch-over on the front panel of device.
 - Min. luminance, set by potentiometer on the front panel, eliminates flashing of light sources.
 - Supply voltage 230 V AC.
- DIM-15**
- Output status is indicated by red LED:
 - shines when output is active.
 - flashes while heating overload, at the same time output is disconnected.
 - 1-MODULE version, DIN rail mounting, saddle terminals.

- SMR-M**
- Button-controlled dimmer intended to be installed in an installation box into the existing electrical wiring.
 - Protection against excessive temperature inside the device - switches off the output.

Connection

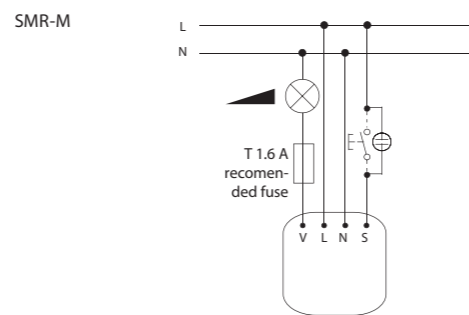
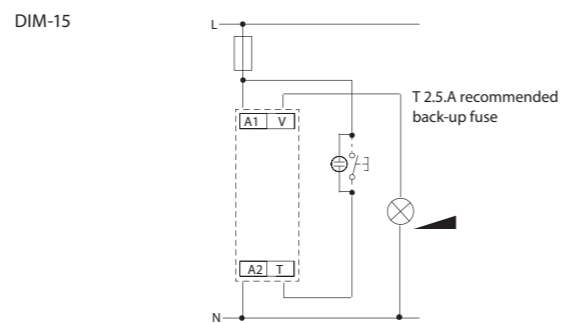

Symbol



Light source type setting

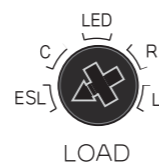

Device description

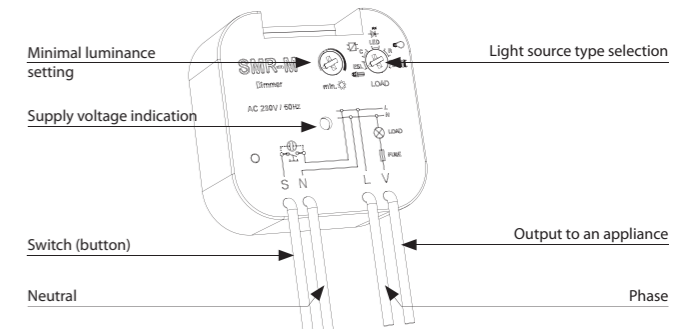
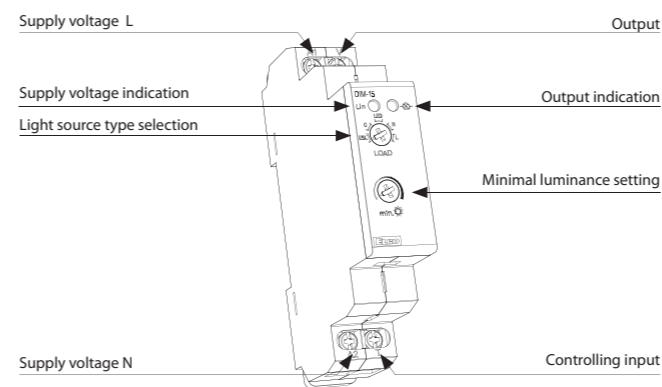

Functions and controlling

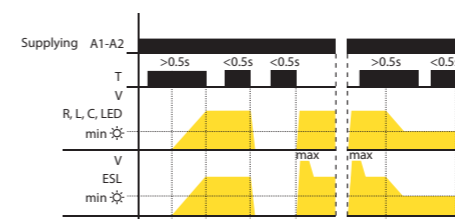

- short button press (<0.5s) turns the light off or on
 - long press (>0.5s) enables slight regulation of light intensity
 - setting of minimal luminance is possible only during decreasing of luminance by long button press
 - setting of minimal luminance by saving fluorescent lamps serves for harmonizing of lowest light intensity prior its unprompted switching off
- Luminance setting:**
LED, R, L, C:
- if the light is turned off, short press (<0.5s) switches the light onto last set luminance level
- ESL:**
- when light is off, short impulse turns lamp on and then luminance is decreased to set level

Connection example

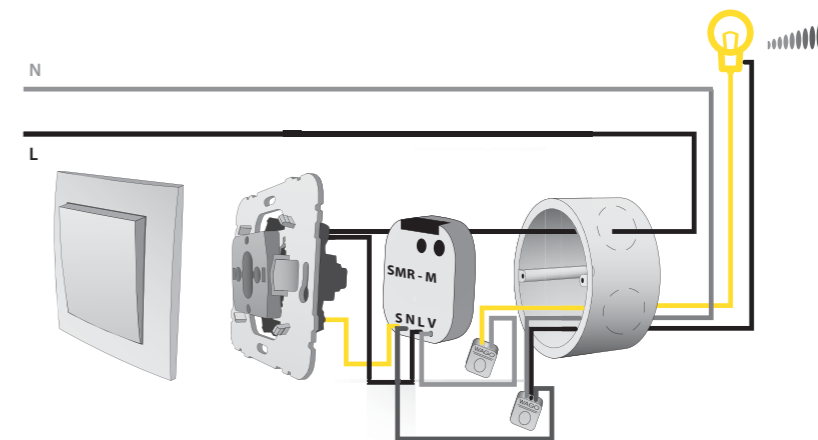

Additional information

- it is not possible to dim energy-saving lamps without marking: dimmable
 - an incorrect setting of light source has effect only on dimming range, it means neither dimmer or load get damaged
 - max. number of dimmable light sources depends on their internal structure
 - it is not recommended to connect light sources with different types and brands, to one dimmer
- list of dimmable sources on page 127



EAN code
SMR-S /230 V: 8595188123518
SMR-U /230 V: 8595188130738

Technical parameters	SMR-S	SMR-U
Connection:	3-wire con., without neutral	4-wire con., with neutral
Voltage range:	230 V AC / 50 Hz	
Power input (no operation/ make):	max. 3 VA	
Supply voltage tolerance:	-15 %; +10 %	
Output		
Resistive load:	10 - 300 VA	500 VA*
Inductive load:	10 - 150 VA	500 VA*
Capacitive load:	x	500 VA*
Control		
Control voltage:	AC 230 V	
Current:	max. 3 mA	
Impulse length:	min. 50 ms / max. unlimited	
Glow tubes connection:	Yes	
Max. amount of glow lamps connected to controlling input:	230 V - max. amount 10 pcs (measured with glow lamp 0.68 mA / 230 V AC)	
Other information		
Operating temperature:	0 °C to +50 °C (32 °F to 122 °F)	
Operating position:	any	
Mounting:	free at connecting wires	
Protection degree:	IP 30 in standard conditions**	
Overvoltage category:	III.	
Pollution degree:	2	
Fuse:	F 1.6 A / 250 V	x
Connection wires:	solid wires 0.75 mm ² (AWG 18) / 90 mm (3.5")	
Glow lamps in a button:	max. number 10	
Dimensions:	49 x 49 x 13 mm (1.9" x 1.9" x 0.5")	
Weight:	32 g (1.1 oz.)	32 g (1.1 oz.)
Standards:	EN 61010-1, EN 60669-2-1	

Note:
* - with load over 300 VA is necessary to ensure sufficient cooling.
** - for more information see page 38

Function



Short press (<0.5s) turns a light on, another short press turns it off. A longer press (>0.5s) causes a gradual regulation of light intensity min-max-min round until the button is released. After releasing a set intensity is kept in memory, further short presses turn the light on/off keeping the set intensity. The intensity can be changed by further long press. After de-energising the relay remembers the set value.

- Button-controlled dimmers designated for flush mounting into a wiring box, into an existing electro-installation (SMR-S doesn't need neutral for correct function).
- Used to control lamp brightness, dimming, possible to control from more places (parallel connections).
- Protection against temperature overrun inside the device – output off.
- By changing wall-switch for a switch with SMR-S/SMR-U installed below you can reach effective brightness control.
- SMR-S enables dimming of electric bulbs 12 V, halogen lights with wound transformers (inductive load).
- SMR-U enables also dimming 12 V halogen lights with electronic transformers (capacitive load).
- it can not be used for dimming of fluorescent lamps and energy saving lamps.
- **SMR-S:**
 - 3-wire connection, functional without neutral
 - max. load: 300 VA (el. bulbs or halogen lights with wound transformer)
 - contactless output -1x triac
 - with exchangeable fuse.
- **SMR-U:**
 - 4-wire connection
 - max. load: 500 VA (el. bulbs or halogen lights with electronic or wound transformer)
 - contactless output - 2x MOSFET
 - electronic over-heating protection - output off in case of short-circuit or overload.

Description of SMR-S

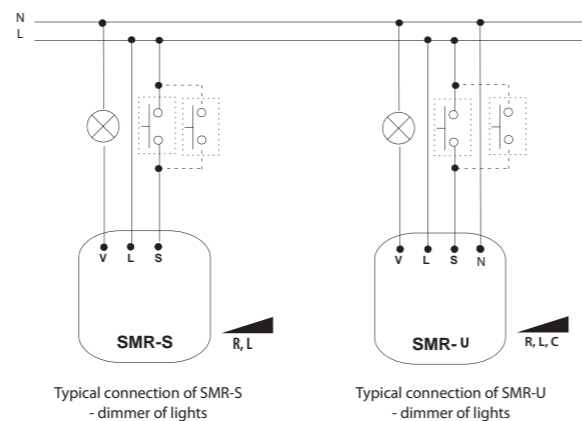
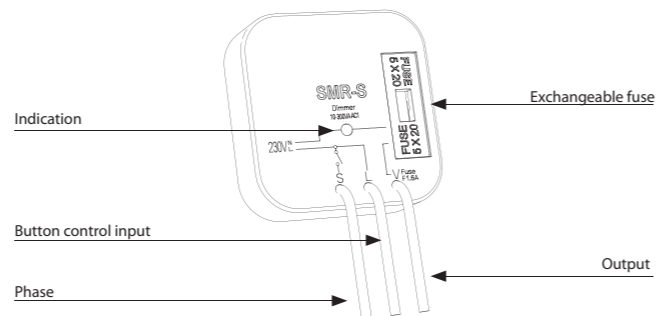

Warning: it cannot be used for fluorescent lights and energy saving lights!
SMR-U: It is not allowed to connect together loads of inductive and capacitive type in the same time.



EAN code
LIC-1 + SKS: 8595188144933
SKS photosensor: 8594030337288

Technical parameters	LIC-1
Supply terminals:	A1 - A2
Supply voltage:	AC 230 V / 50 - 60 Hz
Supply voltage tolerance:	±15 %
Apparent/loss power input:	max. 1.6 VA / 0.8 W
Power supply indication:	green LED
Control	
Button - control. terminals:	A1 - T
Control voltage:	AC 230 V
Control input power:	max. 0.6 VA
Control impulse length:	min. 80 ms / max. unlimited
Glow tubes connection (terminals: L - T):	Yes
Maximum number of connected glow lamps the control input:	230 V - max. amount 50 pcs (measured with glow lamp 0.68 mA / 230 V AC)
Blocking input - terminals:	A1 - B
Control. voltage:	AC 230 V
Supply:	max. 0.1 VA
Connect glow-lamps (terminals L - B):	No
Impulse length:	min. 80 ms / max. unlimited
Output	2x MOSFET
Output status indication:	red LED
Load capacity:*	300 W (at cos φ = 1)
Other information	
Operating temperature:	-20 °C to +35 °C (-4 °F to 95 °F)
Storage temperature:	-20 °C to +60 °C (-4 °F to 140 °F)
Operating position:	any
Mounting:	DIN rail EN 60715
Ingress protection:	IP 40 from front panel / IP 10 terminals
Overvoltage category:	III.
Contamination degree:	2
Connecting conductor cross-section (mm ²):	solid wire max. 2x 2.5 or 1x 4 with sleeve max. 1x 2.5 or 2x 1.5 (AWG 12)
Dimensions:	90 x 17.6 x 64 mm (3.5" x 0.7" x 2.5")
Weight:	66 g (2.33 oz.)

* Due to a large number of light source types, the maximum load depends on the internal construction of dimmable LEDs and ESL bulbs and their power factor cos φ. The power factor of dimmable LEDs and ESL bulbs ranges from cos φ = 0.95 to 0.4. An approximate value of maximum load may be obtained by multiplying the load capacity of the dimmer by the power factor of the connected light source.
- Overview of dimmable light sources on page 127
- List of tested light sources can be found here: www.elkoep.com/solutions/

- Automatically regulates the intensity of light in a room.
- External sensor scans the intensity and based on the preset value it decreases or increases the brightness of light.
- Designed for dimming the LED lights, ESL - dimmable energy saving lamps, R - inductive, L - resistive and C - capacitive load.
- Operating status:
 - 1 - Off.
 - 2 - Automatic regulation.
 - 3 - Cleaning (maximum level of illumination).
 - 4 - Setting the minimum lighting brightness.
 - 5 - Setting the desired level of illumination.
- Optional connection of buttons with 50 neon lamps.
- Blocking the automatic control via external signal.
- Power supply 230 V AC.
- 1-MODULE, DIN rail mounting, clamping terminals.

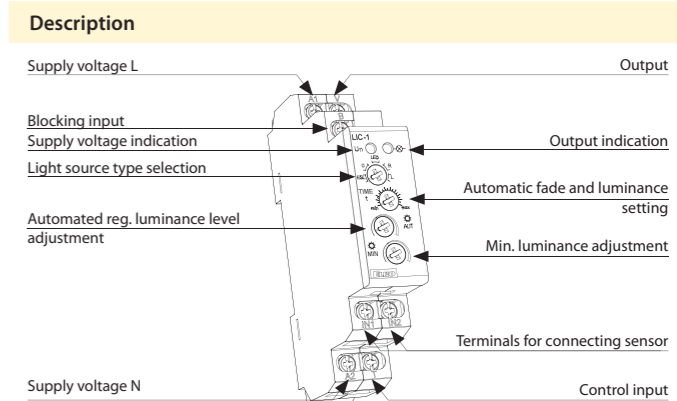

Connection

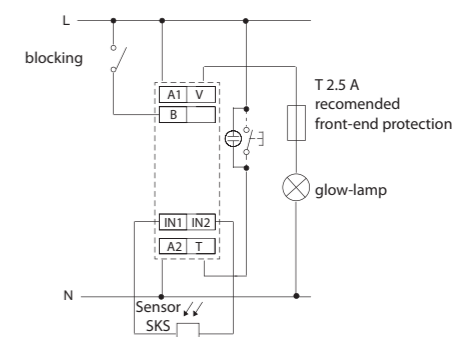

Function

T-button control:
- pressing button shortly (< 0.5s) always turns of lamp
- pressing button longer (0.5... 3s) turns on lamp in automatic regulation mode
- pressing button long (> 3s) turns on lamp to full illumination - „cleaner“ mode
- after turning on the power supply, the dimmer is always turned off

Thyristor B:
serves to block automatic regulation (lamp turns off)
WARNING! The lamp may be turned on in „cleaner“ mode even while blocked.
After ending block mode, the lamp remains off.

Symbol

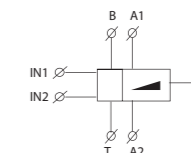



EAN code
LIC-2 + SKS: 8595188145312
SKS photosensor: 8594030337288

Technical parameters		LIC-2
Supply terminals:	L - N	
Supply voltage:	AC 100 - 250 V / 50 - 60 Hz	
Consumption apparent / loss:	max. 2.7 VA / 1.4 W	
Power supply indication:	green LED	
Control		
Button - control terminals:	L - T	
Control voltage:	AC 100 - 250 V	
Impulse length:	min. 80 ms / max. unlimited	
Glow tubes connection:	No	
Button - control terminals:	L - B	
Glow tubes connection:	No	
Duration of control pulse:	min. 80 ms / max. unlimited	
Output 1		
Analog:	0 - 10 V / 10 mA max. or 1 - 10 V / 10 mA max.	
Terminals:	OUT+, OUT-	
Galvanically separated:	Yes	
Output 2		
Number of contacts:	1x switching (AgSnO ₂)	
Current rating:	16 A / AC1	
Switching capacity:	4000 VA / AC1, 384 W / DC	
Peak current:	30 A / < 3 s	
Switching voltage:	250 V AC1 / 24 V DC	
Min. switching capacity DC:	500 mW	
Output indication:	red LED	
Mechanical life:	3x10 ⁷	
Electrical life (AC1):	0.7x10 ⁵	
Other information		
Operating temperature:	-20.. +55 °C (-4 to 131 °F)	
Storage temperature:	-20.. +60 °C (-4 to 140 °F)	
Operating position:	any	
Mounting:	DIN rail EN 60715	
Ingress protection:	IP 40 from front panel / IP 20 terminals	
Overvoltage category:	III.	
Contamination degree:	2	
Connecting cond. cross-section (mm ²):	max. 1x 2.5, max. 2x 1.5, with sleeve max. 1x 2.5 (AWG 12)	
Dimensions:	90 x 17.6 x 64 mm (3.5" x 0.7" x 2.5")	
Weight:	78 g (2.8 oz.)	
Standards:	EN 60669-2-1, EN 61010-1, EN 60929	

Symbol

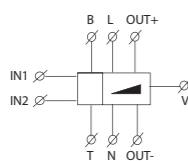

- Serves as control unit for dimmers or electronic ballasts with analog control 0-10 V / 1-10 V.
- Keeps a preset lighting intensity (automatic regulation).
- Control operating modes using existing button:
 - switch OFF
 - automatic regulation
 - cleaning (maximum illumination level)
- Setting the basic parameters of lighting is performed by potentiometers:
 - min. brightness of illumination
 - maximum illumination level
 - speed of dimming / illumination
- Blocking the automatic control using external signal.
- Power supply AC 100 - 250 V.
- 1-MODULE, DIN rail mounting.

Device description

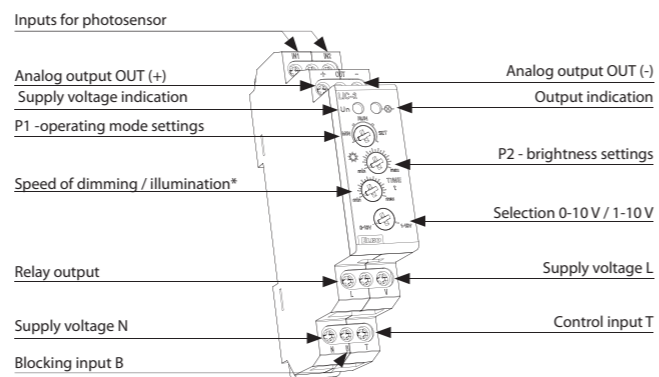

* if the level of brightness on P2 is set on maximum the range is 24...120s

Connection

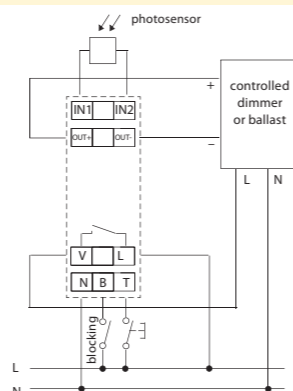

Functions

- Control button functions**
- short press (< 0.5s) - always switches off output (relay and output voltage)
 - longer press (0.5...3s) - runs automatic regulation of brightness level (according to sensor)
 - long press (> 3s) - sets the max. brightness level (CLEANING mode).

Blocking input function

- switches off lighting - only in automatic regulation mode (has no influence in CLEANING mode), e.g. for central switching off of lighting.

Output relay

- switches on always upon switching on the lighting using the button if the DC output voltage is greater than 0.1V (for the mode 0-10 V) or 1V (for the mode 1-10 V)
- upon switching off the light, the relay opens if the output voltage drops below the stated limits

Red LED

- illuminates upon active output (at any brightness level)
- flashes upon activation of blocking



EAN code
DCDA-33M: 8595188146807

Technical parameters		DCDA-33M
Supply terminals:	Un+, GND	
Supply voltage:	12 - 60 V DC	
Consumption:	min. 0.5 W max. 165 W	
Supply voltage from CIB / tolerance:	27 V DC, -20 / +15 %	
Outputs		
Dimming load:	LED chips connected in a series or parallel*, RGB with common anode	
Number of channels:	3	
Rated current:	350 mA - 2 A	
Output power:	3x 50 W	
Output voltage:	6.5 - 55 V	
Switching voltage:	Un	
Output indication	LED OUT1, OUT2, OUT3	
- light:	ON	
- short:	flashing	
- no light:	OFF	
Control		
DALI:	1200bit/s, 250 mA	
CIB:	compatible with iNELS3, consumption < 4 mA	
DMX:	250 kbit/s, 512 channels, control RGB(M) 3(4) channels	
Other information		
Air humidity:	max. 80 %	
Operating temperature:	-20°C to +55°C (-4 °F to 131 °F)	
Storage temperature:	-30°C to +70°C (-22 °F to 158 °F)	
Protection degree:	IP 20 device, IP 40 mounity in the switchboard	
Overvoltage category:	II.	
Pollution degree:	2	
Operating position:	vertical	
Installation:	into switchboard on DIN rail EN60715	
Implementation:	3-module	
Dimension:	90 x 52 x 65 mm (3.5" x 2" x 2.6")	
Weight:	135g (4.76 oz.)	

* For more detailed information, please check the manual.

Setting DIP switches

Setting the communication interface DALI using switch buttons 1 and 2.



Setting the communication interface CIB using switch buttons 1 and 2.



Setting the communication interface DMX using switch button 1. Setting address using switch buttons 2-10.

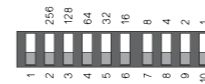

- DCDA-33M is a dimming unit designed to dim single-color and RGB LED light sources controlled by variable current.
- The actuator has three independent channels and each output channel is individually addressable and controllable.
- DCDA-33M actuator can be controlled from the bus DALI, DMX or CIB.
- When controlling the unit from the buses CIB and DMX, also the fourth virtual channel can be supported to control overall brightness (CIB - switching in iDM3, DMX - switch long press of PRG).
- DCDA-33M can directly control from the system iNELS where the communication interface is the installation CIB.
- If for controlling, a communication interface DALI or DMX is used, it is possible to use the master unit EMDC-64M.
- The supply voltage of the dimming unit must be at least 4 V higher than the expected output voltage on the load*.
- Setting the communication interface and addresses of actuators is performed using DIP switches:
 - a) switch No. 1
 - In the upper position determines DALI or CIB
 - In the lower position determines DMX
 - b) switch No. 2 (if that switch 1 is in the upper position)
 - In the upper position determines DALI
 - In the lower position determines CIB
- Using the control buttons on the front panel, you can manually control the output.
- The input circuits of communication interfaces are optically isolated from the supply voltage connected lamp unit, and is therefore resistant to electromagnetic interference.
- DCDA-33M in 3-module is designed for panel mounting on DIN rail EN60715.

Description

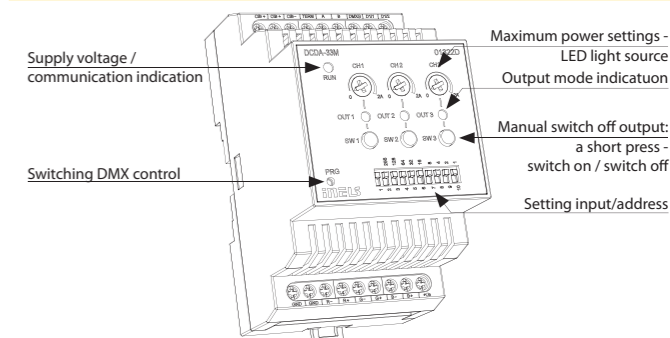

Connection

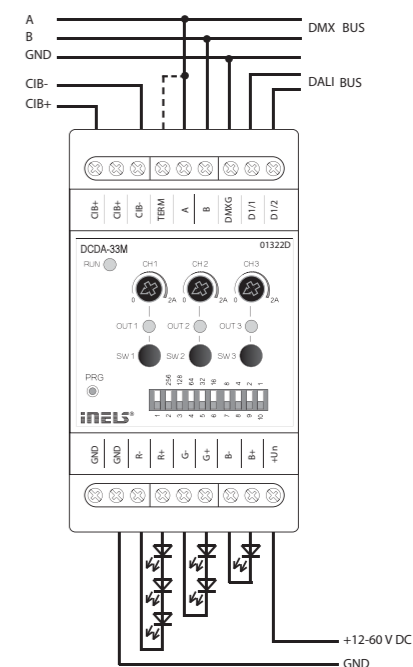

Stabilized DC - switching

Voltage 12 V



PSB-10-12
IN: AC 110-250 V
OUT: DC 12V stabil
LOAD: 0.84 A / 10 W
- galvanically separated
- electronic fuse
- thermo protection
- MINI, into an installation box (such as KU-68).



PS-10-12
IN: AC 184-250 V
OUT: DC 12 V stabil
LOAD: 0.84 A / 10 W
- galvanically separated
- fusion safety
- electronic fuse
- thermo protection
1 MODULE.



PS-30-12
IN: AC 100-250 V
OUT: DC 12 V stabil
LOAD: 2.5A / 30 W
- galvanically separated
- electronic fuse
- thermo protection
3 MODULE.



DR-60-12
IN: AC 100-240 V
OUT: DC 12 V stabil
LOAD: 4.5A / 54 W
- galvanically separated
- electronic fuse
- range of incoming voltage
4.5 MODULE.



PS-100-12
IN: AC 100-250 V
OUT: DC 12 V stabil
LOAD: 8.4A / 100 W
- galvanically separated
- fusion safety
- electronic fuse
- thermo protection
6 MODULE.

Stabilized DC - linear

Nonstabilized AC+DC



ZNP-10-12
IN: AC 230 V
OUT: AC/DC 12V nostabil
LOAD: 0.4A / 10 VA
- galvanically separated
- fuse
3 MODULE.

Voltage 24 V



PSB-10-24
IN: AC 110-250 V
OUT: DC 24 V stabil
LOAD: 0.42A / 10 W
- galvanically separated
- electronic fuse
- thermo protection
MINI, into an installation box (such as KU-68).



PS-10-24
IN: AC 184-250 V
OUT: DC 24 V stabil
LOAD: 0.42A / 10 W
- electronic fuse
- thermo protection
1 MODULE.



PS-30-24
IN: AC 100-250 V
OUT: DC 24 V stabil
LOAD: 1.25A / 30 W
- galvanically separated
- electronic fuse
- thermo protection
3 MODULE.



DR-60-24
IN: AC 100-240 V
OUT: DC 24 V stabil
LOAD: 2.5A / 60 W
- galvanically separated
- electronic fuse
4.5 MODULE.



PS-100-24
IN: AC 100-250 V
OUT: DC 12 V stabil
LOAD: 4.2A / 100 W
- fusion safety
- electronic fuse
- thermo protection
6 MODULE.



ZNP-10-24
IN: AC 230 V
OUT: AC/DC 24V nostabil
LOAD: 0.4A / 10 VA
- galvanically separated
- fuse
3 MODULE.

Regulated



PS-30-R
IN: AC 100-250 V
OUT: DC 12-24 V regul., stab.
LOAD: 2.5-1.25A / 30 W
- galvanically separated
- electronic fuse
- thermo protection
3 MODULE.



ZSR-30
IN: AC 230 V
OUT: DC 5-24 V reg., stab.
OUT: AC 24V, DC24V
LOAD: 1.6-0.3A/10 VA
- range of incoming voltage
- current restrictor
- electronic fuse
3 MODULE.

Nonstabilized AC

Bell transformer



ZTR-8-8
Output voltage 8 V.
Power: 8W.



ZTR-8-12
Output voltage 12 V.
Power: 8W.

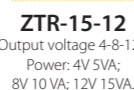

ZTR-15-12
Output voltage 4-8-12 V.
Power: 4V 5VA;
8V 10 VA; 12V 15VA.

Type	Design	Input voltage	Output				Protection against overload			Designation	Page in catalogue		
			AC	DC	Stabilized	Output voltage	Output current	Switching (S) / Linear (L)	Safety fuse			Electronic fuse	Short-circuit-proof
ZNP-10-12	3M-DIN	AC 230 V, -15/+10%	●	●	x	AC 12V DC 12V	0.8 A	x	●	x	x	DC and AC nonstabilized, output voltage 12 V – where it is not required or where there is stabilized differently/later	55
ZNP-10-24	3M-DIN	AC 230 V, -15/+10%	●	●	x	AC 24V DC 24V	0.4 A	x	●	x	x	DC and AC nonstabilized output voltage 24 V – where it is not required or is stabilized later	55
ZSR-30	3M-DIN	AC 230 V, -15/+10%	●	●	●	DC 5-24V AC 24V	1.6 A- 0.3 A	S	●	●	x	regulated output voltage in a wide range DC 5-24 V; possibility to adjust output voltage with load according to request...	55
PSB-10-12	MINI-BOX	AC 110-250 V	x	●	●	DC 12 V	0.84 A	S	x	●	●	stabilized switching power supply with fixed output voltage 12 V / 10 W, box	52
PSB-10-24	MINI-BOX	AC 110-250 V	x	●	●	DC 24V	0.42 A	S	x	●	●	stabilized switching power supply with fixed output voltage 24 V / 10 W, box	52
PS-10-12	1M-DIN	AC 184-250 V, -20/+10%	x	●	●	DC 12 V	0.84 A	S	●	●	●	stabilized switching power supply with fixed output voltage 12 V / 10 W, 1 module	52
PS-10-24	1M-DIN	AC 184-250 V, -20/+10%	x	●	●	DC 24V	0.42 A	S	●	●	●	stabilized switching power supply with fixed output voltage 24 V / 10 W, 1 module	52
PS-30-12	3M-DIN	AC 100-250 V, -20/+10%	x	●	●	DC 12 V	2.5 A	S	●	●	●	stabilized switching power supply with fixed output voltage 12 V / 30 W, 3 module	52
PS-30-24	3M-DIN	AC 100-250 V, -20/+10%	x	●	●	DC 24V	1.25 A	S	●	●	●	stabilized switching power supply with fixed output voltage 24 V / 30 W, 3 module	52
PS-30-R	3M-DIN	AC 100-250 V, -15/+10%	x	●	●	DC 12-24V	2.5 A- 1.25A	S	●	●	●	stabilized switching power supply with fixed output voltage 12-24 V / 30 W, 3 module	52
PS-100-12	6M-DIN	AC 100-250 V, -20/+10%	x	●	●	DC 12 V	8.4A	S	●	●	●	stabilized switching power supply with fixed output voltage 12 V / 100 W, 6 module	52
PS-100-24	6M-DIN	AC 100-250 V, -20/+10%	x	●	●	DC 24V	4.2 A	S	●	●	●	stabilized switching power supply with fixed output voltage 24V / 100W, 6 module	52
DR-60-12	4.5M-DIN	AC 100-240 V DC 124-370 V	x	●	x	DC 12 V	4.5 A	S	x	x	x	efficient switching power supply of DC voltage 12V / 54 W, wide range of input voltage (AC 100-240 and DC 124-370 V)	54
DR-60-24	4.5M-DIN	AC 100-240 V DC 124-370 V	x	●	x	DC 24V	2.5 A	S	x	x	x	efficient switching power supply of DC voltage 24V / 60 W, wide range of input voltage (AC 100-240 and DC 124-370 V)	54
ZTR-8-8	2M-DIN	AC 230 V, -15/+10%	●	x	x	8V	1A	x	x	x	●	bell transformer (short-circuit-proof) for supplying of bells, door openers, home call-boxes	56
ZTR-8-12	2M-DIN	AC 230 V, -15/+10%	●	x	x	12V	0.66A	x	x	x	●		56
ZTR-15-12	3M-DIN	AC 230 V, +/- 10%	●	x	x	4-8-12V	2-1.5-1A	x	x	x	●		56



- **PSB-10:** switching stabilized power supplies with fixed output voltage, for mounting into an installation box.
 - PSB-10-12 - stabilized power supply 12V/10W.
 - PSB-10-24 - stabilized power supply 24V/10W.
- **PS-10:** switching stabilized power supplies with fixed output voltage, version 1-module.
 - PS-10-12 - stabilized power supply 12 V/10 W.
 - PS-10-24 - stabilized power supply 24 V/10 W.
- **PS-30:** switching stabilized power supplies, version 3-module.
 - PS-30-12 - stabilized power supply with fixed output voltage 12V/30W.
 - PS-30-24 - stabilized power supply with fixed output voltage 24V/30W.
 - PS-30-R - stabilized regulated power supply 12-24 V/30 W.
- **PS-100:** stabilized power supply with fixed output voltage, version 6-module.
 - PS-100-12 - stabilized power supply 12 V/100 W.
 - PS-100-24 - stabilized power supply 24 V/100 W.
- Output current is limited by electronic fuse, in case maximal current is exceeded, the device switches off and after a shot time interval it again switches on.
- Indication of output voltage by green LED on front panel (except PSB-10).
- Temperature protection - if temperature is exceeded, the device switches off and after cooled down, it switches on again.

EAN code
 PSB-10-12: 8595188145022 PS-30-12V: 8595188137966
 PSB-10-24: 8595188143783 PS-30-24V: 8595188139045
 PS-10-12V: 8595188139052 PS-30-R: 8595188136655
 PS-10-24V: 8595188139069 PS-100-12V: 8595188137195
 PS-100-24V: 8595188139021

Technical parameters	PSB-10-12	PSB-10-24	PS-10-12	PS-10-24	PS-30-12	PS-30-24	PS-30-R	PS-100-12	PS-100-24
Input									
Voltage range:	AC 110 - 250 V / 50 - 60 Hz		AC 184 - 250 V / 50 - 60 Hz		AC 100 - 250 V / 50 - 60 Hz			AC 100 - 250 V / 50 - 60 Hz	
Burden without load (max.):	3 VA / 0.5 W		5 VA / 2 W		9 VA / 1 W	10 VA / 1.5 W	10 VA / 1.7 W	12 VA / 2 W	
Burden with full load (max.):	26 VA / 13 W		25 VA / 13 W		70 VA / 37 W			195 VA / 121 W	
Protection:	x		fuse T1A		fuse T2A			fuse T 3.15A	
Output									
Output voltage DC / max. current:	12 V / 0.84 A	24 V / 0.42 A	12.2 V / 0.84 A	24.2 V / 0.42 A	12.2 V / 2.5 A	24.2 V / 1.25 A	12.2 V / 2.5 A	12.2 V / 8.4 A	24.2 V / 4.2 A
Tolerance of output voltage:	± 2 %		± 2 %		± 2 %			± 2 %	
Output indication:	x		green LED						
Wave of off-load output voltage:	40 mV		80 mV		30 mV	40 mV	1 V		
Wave of output voltage with max load:	380 mV		20 mV		80 mV	500 mV	40 mV		
Time delay after connection:	max. 1s		max. 1s		max. 5s	max. 1s	max. 3s		
Time delay after over-load:	max. 1s		max. 1s		max. 1s	max. 0.5s			
Efficiency:	> 75 %		> 75 %		> 82 %	> 81 %	>82 %		
Electronic fuse:	electronic protections short-circuit, over load, over voltage (from 120% of rated output)								
Other information									
Working humidity:	20 .. 90% RH								
Operating temperature:	-20 °C to +40 °C (-4 °F to 104°F)								
Storage temperature:	-40 °C to +85 °C (-40 °F to 185 °F)		-40 °C to +85 °C (-40 °F to 185 °F)		-25 °C to +70 °C (-13 °F to 158 °F)			-40 °C to +85 °C (-40 °F to 185 °F)	
Electrical strength input- output:	4kV								
Protection degree:	IP 30		IP40 device/ IP20 in-built in distribution board						
Overvoltage category:	II.								
Polution degree:	2								
Max. cable size (mm ²):	x		solid wire max.1x2.5 or 2x1.5/ with sleeve max.1x1.5 (AWG 13)						
Connection wires:	solid wire CY, 4x0.75mm ² (AWG 18), 90mm (3.5")		x						
Dimensions:	48 x 48 x 21 mm (1.9 x 1.9 x 0.8")		90 x 17.6 x 64 mm (3.5" x 0.7" x 2.5")		90 x 52 x 65 mm (3.5" x 2.1" x 2.6")			90 x 105 x 65 mm (3.5" x 4.1" x 2.6")	
Weight:	70 g (2.5 oz)	70 g (2.5 oz)	62 g (2.1 oz.)	62 g (2.1 oz.)	158 g (5.6 oz.)	158 g (5.6 oz.)	158 g (5.6 oz.)	367 g (12.9 oz.)	367 g (12.9 oz.)
Standards:	EN 61204-1, EN 61204-3, EN 61204-7								

Device description

PSB-10-12

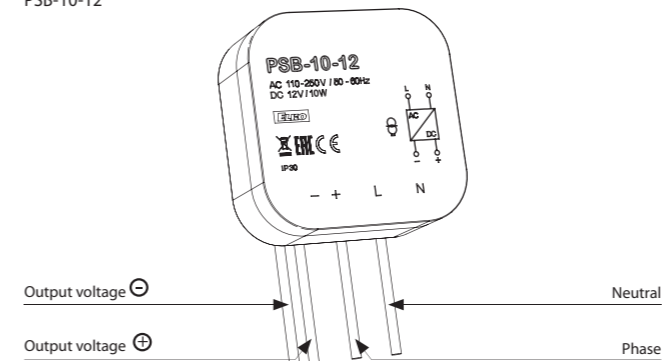

NEW

PSB-10-12 / PSB-10-24 designated for installation into an installation box. Suitable for controlling of lighting sources, thermo valves, shutter engines, etc.

PS-10-12

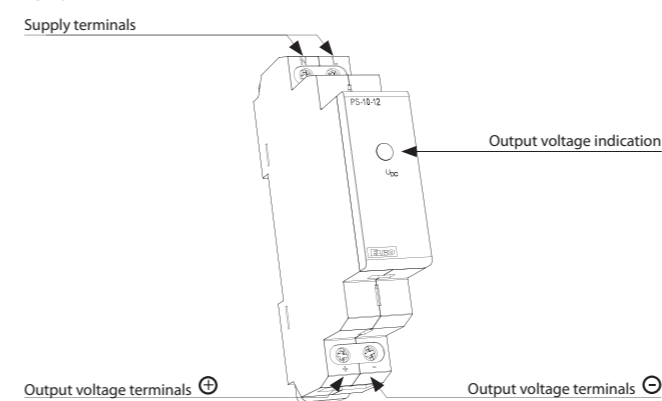

PS-30-12

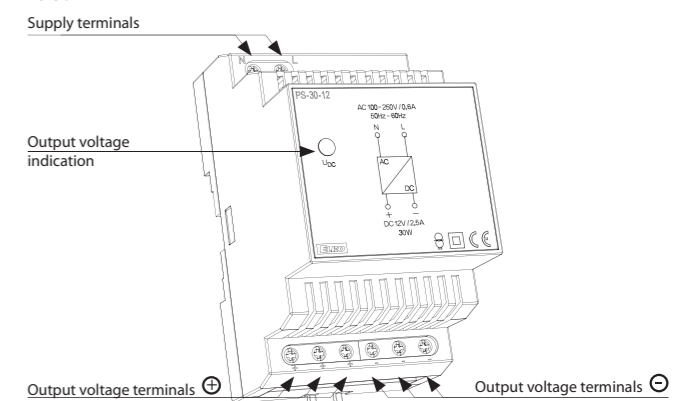

PS-100-12

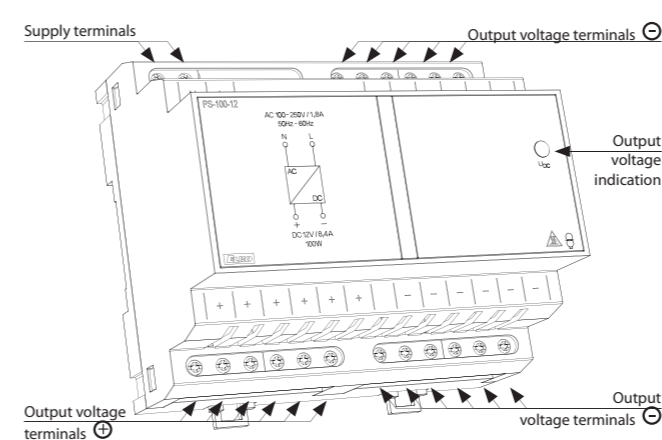

PS-30-R

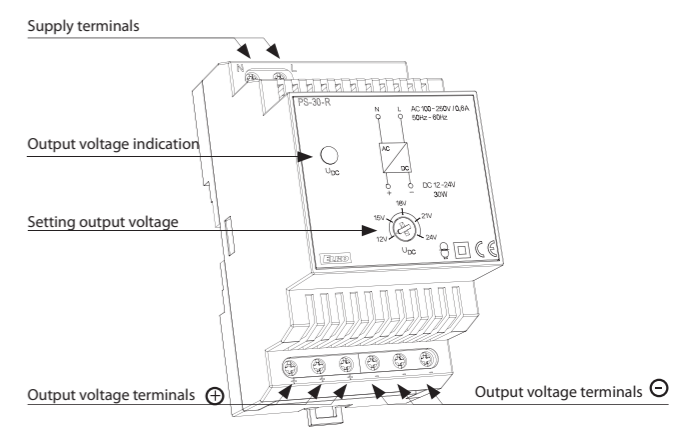

Connection

PSB-10-12 (PSB-10-24)

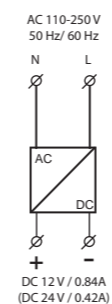

PS-10-12 (PS-10-24)

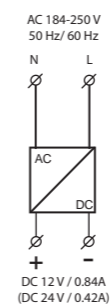

PS-30-12 (PS-30-24)

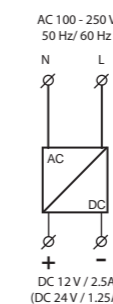

PS-30-R

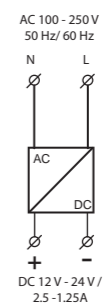

PS-100-12 (PS-100-24)

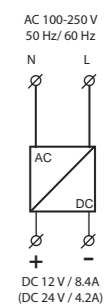



EAN code
DR-60-12V: 8595188125048
DR-60-24V: 8595188125055

Technical parameters	DR-60-12	DR-60-24
Input (U prim)		
Voltage range:	88 - 264 V AC / 47 - 63 Hz or 124 - 370 V DC	
Supply voltage tolerance:	in the range of supply voltage	
Consumption without load (max):	3 VA	
Consumption with full load (max):	AC 65 VA	AC 70 VA
Output (Usec)		
Output voltage:	12 V ±10 %	24 V ±10 %
Max. load:	4.5 A / 54 W	2.5 A / 60 W
Output voltage-no load DC:	12 V ±10 %	24 V ±10 %
Wave of output voltage:	0.12 V	0.15 V
Efficiency:	83.5 %	86 %
Tolerance of output voltage:	±1 %	
Electronic fuse:	electronic protections short-circuit, over load, over voltage	
Fine adjustment of output voltage:	±10 % - trimmer	
Overload protection:	to 105 - 160 % of rated output	
Time delay after connection:	100 ms for 100 % loading and AC 230 V	
Other information		
Working humidity:	20 - 90 % RH	
Thermal coefficient:	0.03 % / °C (0 to 50 °C) (0.03 % / °F (32 °F to 122 °F))	
Operating temperature:	-20 °C to +60 °C (-4 °F to 140 °F)	
Storage temperature:	-40 °C to +85 °C (-40 °F to 185 °F) / (10 - 95 % RH)	
Electrical strength (prim/sec):	3 kV	
Protection degree:	IP 20 device / IP 40 in-built in distribution board	
Max. cable size (mm ²):	solid wire max. 1x 2.5 or 2x 1.5 / with sleeve max. 1x 1.5 (AWG 10)	
Dimensions:	78 x 93 x 56 mm (3.1" x 3.7" x 2.2")	
Weight:	300 g (10.6 oz.)	
Standards:	EN 61010-1, EN 61558-1, EN 61558-2-17	

- Stabilized switching power supply.
- Input voltage (Uprim) in a wide range 100 - 240 V AC.
- **DR-60-12:** power supply with fixed output voltage DC 12 V, stabilized 54 W.
- **DR-60-24:** power supply with fixed output voltage DC 24 V, stabilized 60 W.
- Max. load 12 V-4.5 A, 24 V-2.5 A.
- Electronic protection of short-circuit, over-loading, over-voltage, fine setting of output voltage by trimmer in a range ±10%.
- LED power indicator light, viewable from the front panel.
- Ambient air cooled through the perforated housing.
- 4.5-MODULE, DIN rail mounting, isolation class II.

Description

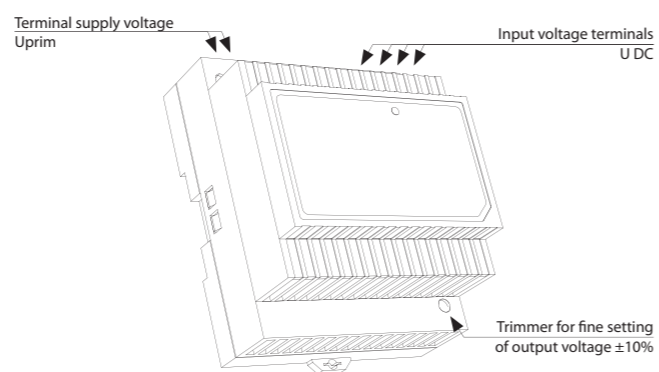

Connection

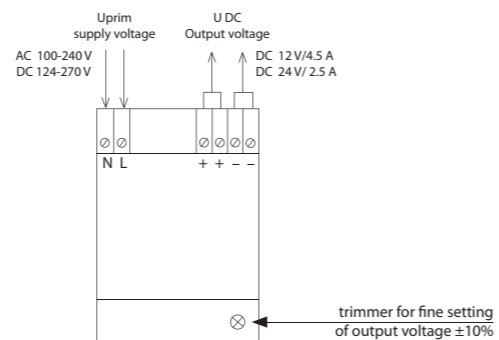

Symbol

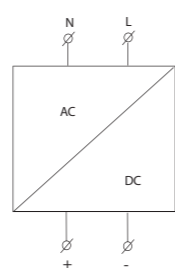

EAN code
ZNP-10-12V: 8594030332733
ZNP-10-24V: 8594030334089
ZSR-30: 8594030331750

Technical parameters	ZSR-30	ZNP-10-12V	ZNP-10-24V
Entry (U prim)			
Voltage range:	AC 230 V / 50 - 60 Hz		
Supply voltage tolerance:	-15 %; +10 %		
Consumption without load (max):	6 VA	7 VA	6.5 VA
Consumption with load (max):	10 VA	11 VA	
Output (Usec)			
Output voltage:	DC 5-24 V stab.	DC 12 V nonstab.	DC 24 V nonstab.
	AC 24 V	AC 12 V	AC 24 V
Output voltage-no load AC:	32 V	17 V	32 V
Output voltage-no load DC:	44 V	22 V	44 V
Fuse:	primary wind T100 mA		
Wave of output voltage:	300 mV	max. 4 V	max. 3 V
Efficiency:	75 %	x	
Tolerance of output voltage:	±5 %	x	
Electronic fuse:	Towards black-out and current overloading	x	
Other information:			
Operating temperature:	-20.. +40 °C (-4 °F to 104 °F)		
Storing temperature:	-20.. +60 °C (-4 °F to 140 °F)		
Electrical strength (prim/sec):	4 kV		
Protection degree:	IP 40 from front panel / IP 20 terminals		
Max. cable size (mm ²):	solid wire max. 1x 2.5 or 2x 1.5 / with sleeve max. 1x 1.5 (AWG 12)		
Dimensions:	90 x 52 x 65 mm (3.5" x 2" x 2.6")		
Weight:	390 g (13.8 oz.)	360 g (13.8 oz.)	360 g (13.8 oz.)
Standards:	EN 61010-1, EN 61558-2-1, EN 61558-1		

WARNING!

Values of max. load are valid for (operational) temperature.
Total loads on all output terminals may not exceed this values:
- by supplying 230 V-253 V - 8W
- from 230 V...207 V output power is proportionately decreasing onto 5 W

Regulated stabilized power supply ZSR-30

- Supply of various devices and appliances by safe voltage with fully galvanic separation from the main.
 - Input voltage: AC 230 V.
 - Output voltage: DC 5-24 V stab., DC 24 V unstab. and AC 24 V.
 - Exceeded current limit values is indicated by LED flashing.
 - When there is full short-circuit, output is disconnected, output current is limited by an electronic fuse.
 - 3-MODULE, DIN rail mounting.
- Nonstabilized power supply ZNP-10-12V, ZNP-10-24V**
- AC and DC output voltage: 12 V or 24 V, nonstabilized.
 - Power supply with fixed output voltage.
 - Protection against short-circuit and overload by a safety fuse.
 - Input voltage: AC 230 V.
 - 3-MODULE, DIN rail mounting.

Description

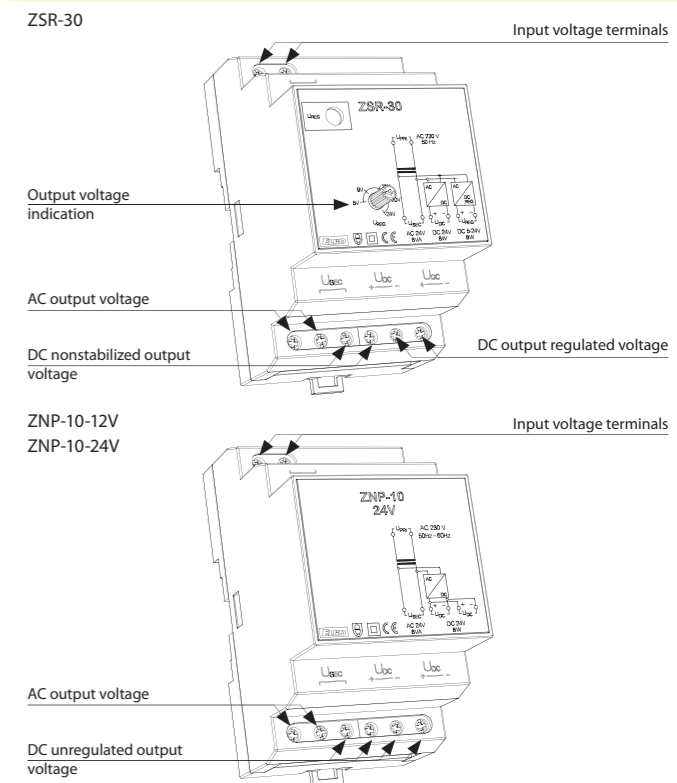

ZSR-30

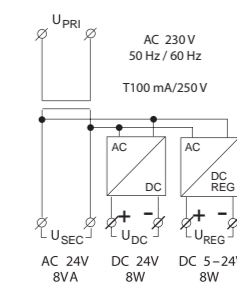

ZNP-10

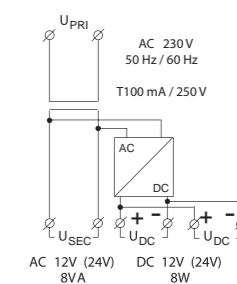



EAN code
ZTR-8-8V: 8595188136808
ZTR-8-12V: 8595188136815
ZTR-15-12V: 8595188139281

- Designated for general use – e.g. for home bells supply, door locks supply.
- Input voltage: AC 230 V.
- Universal power supply with AC input voltage.
- Short-circuit-proof, doubled output terminals.

- 2-MODULE, DIN rail mounting.
ZTR-8-8: output voltage 8 V.
ZTR-8-12: output voltage 12 V.

- 3-MODULE, DIN rail mounting.
ZTR-15-12: output voltage 4, 8,12V.

Technical parameters ZTR-8-8 ZTR-8-12 ZTR-15-12

Entry (U prim)			
Voltage range:	AC 230 V / 50 Hz		
Supply voltage tolerance:	-15 %; +10 %	± 10 %	
Consumption without load (max):	7.2 VA	9.4 VA	3.5 VA
Output (Usec)			
Output voltage:			AC 4 V AC 8 V AC 12 V
	AC 8 V	AC 12 V	
Output voltage-no load AC:	12 V	16 V	16 V
Max. loadability:	8 A	8 VA	4V 5VA, 8V 10 VA, 12 V 15VA
Fuse:	short-circ.resistant		
Other information			
Operating temperature:	-20.. +40°C (-4 °F to 104 °F)		
Storing temperature:	-20.. +60°C (-4 °F to 140 °F)		
Electrical strenght (prim/sec):	3.75 kV		
Protection degree:	IP 20 / 40		
Max. cable size (mm ²):	solid wire max. 1x 2.5 or 2x 1.5 / with sleeve max. 1x 1.5 (AWG 12)		
Dimensions:	90 x 35.6 x 64 mm (3.5" x 1.4" x 2.6")	90 x 52 x 65 mm (3.5" x 2" x 2.6")	
Weight:	314 g (11.1 oz.)	312 g (11 oz.)	350 g (12.3 oz.)
Standards:	EN 61558-1, EN 61558-2-8, EN 61558-2-1		

Connection

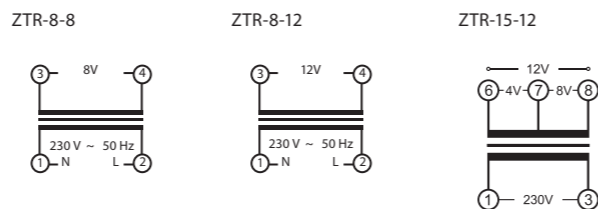

SOU-1
Twilight switch.
Voltage range:
AC 230 V or
AC/DC 12-240 V
Output contact:
1x changeover/SPDT 16 A.



SOU-2
Twilight switch with digital
time clock.
Voltage range:
AC 230 V / 50 - 60 Hz
Output contact:
1x changeover/SPDT 8 A.



SOU-3
Twilight and light switch.
Voltage range:
AC 230 V / 50 - 60 Hz
Output contact:
1x NO/SPST 16 A.

Accessories of twilight switches:



Photosensor SKS
Protection degree: IP56.
It is suitable for mounting on the wall
or in panel.

MEMORY RELAYS



MR-41
Voltage range:
AC 230 V or
AC/DC 12 -240 V
Output contact:
1x changeover/SPDT 16 A.



MR-42
Voltage range:
AC 230 V or
AC/DC 12 -240 V
Output contact:
2x changeover/DPDT 16 A.

CONTROL AND SIGNALLING DEVICES



USS
Designated for switching,
controlling and signalling
by auxiliary any power
circuits.

- SWITCHES, PUSH BUTTONS
- SWITCHES WITH GLOW LAMP
- SIGNALLING LIGHT
- BLIND FLANGE

Type	Design	Power supply	Output contact	Other				Designation	Page of catalogue
				LED indication	Display	Internal sensor	External sensor		
SOU-1	1M-DIN	AC 230 V/50-60 Hz	1x16 A changeover	●	x	x	●	Is used to control lights on the basis of ambient light intensity	59
		AC/DC 12-240 V (AC 50-60 Hz)							
SOU-2	2M-DIN	AC 230 V/50-60 Hz	1x8 A changeover	x	●	x	●	Is used for control of lights on the basis of ambient light intensity and real time (combination of SOU-1 and time switch clock SHT-1 in one device)	60
SOU-3	IP65	AC 230 V/50-60 Hz (AC 50-60 Hz)	1x16 A NO-SPST	x	x	●	x	Is used as control of the device on the basis of ambient light intensity	61

Type	Design	Power supply	Output contact	Other			Designation	Page of catalogue
				LED indication	Control output	Function		
MR-41	1M-DIN	AC 230 V/50-60 Hz	1x16 A changeover	●	●	1	Latching relays, controlled by buttons from several locations can replace three way switches or cross bar switches thanks to control by buttons (unlimited number, connected in parallel by 2 wires), installation gets more transparent and faster for mounting.	62
		AC/DC 12-240 V (AC 50-60 Hz)						
MR-42	1M-DIN	AC 230 V/50-60 Hz	2x16 A changeover	●	●	2		62
		AC/DC 12-240 V (AC 50-60 Hz)						



EAN code
SOU-1/230 V + SKS: 8595188121002
SOU-1/UNI + SKS: 8595188121019
Photosensor SKS: 8594030337288

Technical parameters		SOU-1
Supply terminals:		A1 - A2
Voltage range:	UNI	AC/DC 12 - 240 V (AC 50 - 60 Hz)
Burden:		AC 0.7 - 3 VA / DC 0.5 - 1.7 W
Voltage range:	230	AC 230 V / 50 - 60 Hz
Power input (apparent/loss):		AC max. 12 VA / 1.8 W
Supply voltage tolerance:		-15 %; +10 %
Supply indication:		green LED
Time delay:		0 - 2 min
Time delay setting:		potentiometer
Illumination rang 1):		1 - 100 lx
Illumination rang 2):		100 - 50000 lx
Output		
Number of contacts:		1x changeover / SPDT (AgSnO ₂)
Current rating:		16 A / AC1
Breaking capacity:		4000 VA / AC1, 384 W / DC
Inrush current:		30 A / < 3 s
Switching voltage:		250 V AC1 / 24 V DC
Min. breaking capacity DC:		500 mW
Output indication:		red LED
Mechanical life:		3x10 ⁷
Electrical life (AC1):		0.7x10 ⁵
Control		
Power the control input:		0.8 - 530 mVA (UNI), 0.8 - 530 mVA (AC 230 V)
Load between S-A2:		Yes
Control. terminals:		A1-S
Glow tubes connctions:		230 V - Yes / UNI - No
Max. amount of glow lamps connected to controlling input:		UNI - glow lamps cannot be connected, 230 V - max. amount 20 pcs (measured with glow lamp 0.68 mA / 230 V AC)
Impulse length:		min. 25 ms / max. unlimited
Reset time:		150 ms
Other information		
Operating temperature:		-20 °C to +55 °C (-4 °F to 131 °F)
Storage temperature:		-30 °C to +70 °C (-22 °F to 158 °F)
Electrical strength:		4 kV (supply - output)
Operating position:		any
Mounting:		DIN rail EN 60715
Protection degree:		IP 40 from front panel / IP 20 terminals
Sensor cable length:		max. 50 m (standard wire)
Overvoltage category:		III.
Pollution degree:		2
Max. cable size (mm ²):		solid wire max. 1x 2.5 or 2x 1.5/ with sleeve max. 1x 2.5 (AWG 12)
Dimensions of the sensor SKS:		66 x Ø 23.5 mm (2.6" x Ø 0.9")
Weight of sensor SKS:		20 g (0.7 oz.)
Dimensions:		90 x 17.6 x 64 mm (3.5" x 0.7" x 2.5")
Weight:		(UNI) - 75 g (2.6 oz.), (230) - 65 g (2.3 oz.)
Standards:		EN 60255-6, EN 61010-1

- Is used to control lights on the basis of ambient light intensity.
- Used for switching street illumination and garden lights, illumination of advertisements, shop windows, etc.
- Level of ambient intensity is monitored by an external sensor and output is switched according to set level on the device.
- Control input for additional control, e.g. time switch, preswitch etc.
- Level of illumination adjustable in two ranges:
1 - 100 lx and 100 - 50000 lx.
- Adjustable time delay to eliminate short term fluctuation in illumination.
- External sensor IP56 suitable for mounting on the wall (cover and holder of a sensor are a part of the package).
- Supply voltage AC 230 V or AC/DC 12 - 240 V.
- Output contact: 1x changeover/ SPDT 16 A.
- Red LED output indication.
- 1-MODULE, DIN rail mounting.

Description

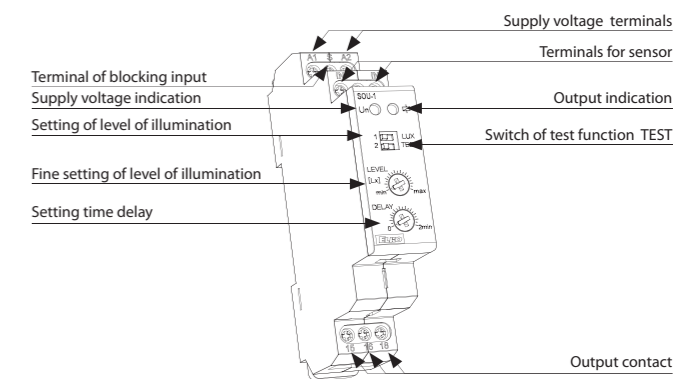

Connection

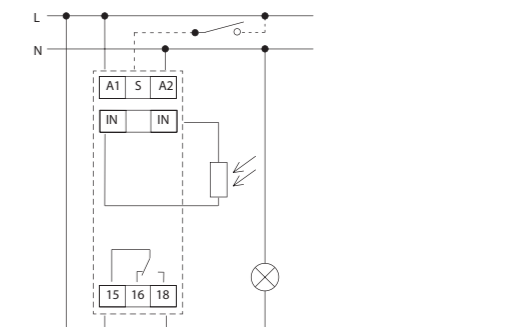

Description of DIP switch

- DIP 1 - LUX
ON
■ 100 - 50000 lx
■ 1 - 100 lx
- DIP 2 - TEST
ON
■ TEST ON
■ NORMAL

Function

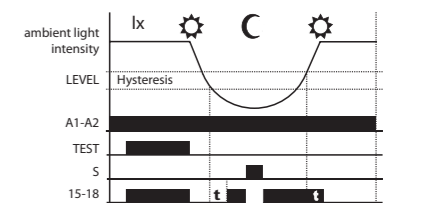

Symbol

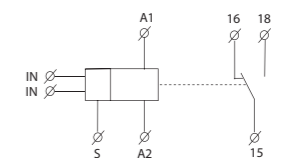



EAN code
SOU-2 + SKS: 8595188130523
SOU-2: 8595188121644
Photosensor SKS: 859403037288

SOU-2

Supply terminals:	A1 - A2
Voltage range:	AC 230 V / 50 - 60 Hz
Burden:	max. 4 VA
Voltage range:	-15 %; +10 %
Back-up supply:	yes
Type of backup battery:	CR 2032 (3V)
Summer / winter time:	automatic

Output

Number of contacts:	1x changeover / SPDT (AgSnO ₂)
Current rating:	8 A / AC1
Breaking capacity:	2000 VA / AC1, 240 W / DC
Switching voltage:	250 V AC1 / 30 V DC
Mechanical life:	1x10 ⁷
Electrical life (AC1):	1x10 ⁵

Time circuit

Power back-up:	3 years
Accuracy:	max. ±1 s day (23 °C / 73.4 °F)
Minimum interval:	1 min
Data stored for:	min. 10 years

Program circuit

Illumination range:	10-50000 lx
Program place number:	100
Program period:	daily, weekly
Data readout:	LCD display, illuminated by back up

Other information

Operating temperature:	-10 °C to +55 °C (-4 °F to 131 °F)
Storage temperature:	-30 °C to +70 °C (-22 °F to 158 °F)
Electrical strength:	4 kV (supply - output)
Operating position:	any
Mounting:	DIN rail EN 60715
Protection degree:	IP 40 from front panel / IP 20 terminals
Overvoltage category:	III.
Pollution degree:	2
Max. cable size (mm ²):	solid wire max. 1x 2.5 or 2x 1.5, with sleeve max. 1x 1.5 (AWG 12)
Dimensions:	90 x 35.6 x 64 mm (3.5" x 1.4" x 2.5")
Weight:	127 g (4.48 oz.)
Dimensions of the sensor SKS:	66 x Ø 23.5 mm (2.6" x Ø 0.9")
Weight of sensor SKS:	20 g (0.7 oz.)
Standards:	EN 61812-1, EN 61010-1, EN 60255-6; EN 60730-1; EN 60730-2-7

Plug-in module



with battery backup

without battery backup

- Is used for control of lights on the basis of ambient light intensity and real time (combination of SOU-1 and time switch clock SHT-1 in one device).
- Time clock can override the light sensor for applications when lights are not required.
- Adjustable light intensity 10-50000 lx.
- Function „random switching“ enables simulation of presence in a house when nobody is at home.
- Switching: according to a program (AUTO) / permanently manual / random (CUBE).
- External sensor IP 56 issuitable for mounting on the wall / in panel (cover and sensors are part of delivery).
- Sealable transparent cover of front panel.
- Backup of data and time by battery (reserve battery up to 3 years).
- Easy replacement of backup battery with plug-in module located on front panel of device (no disassembly required).
- 2-MODULE, DIN rail mounting .

Description

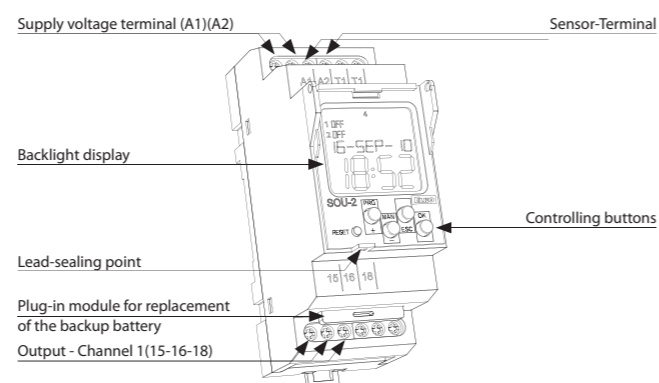

Description of visual elements on the display

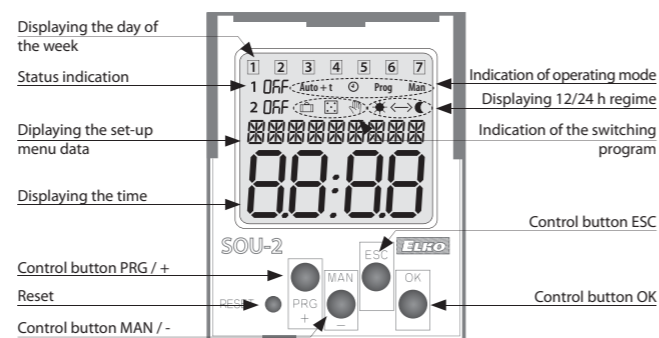

Connection

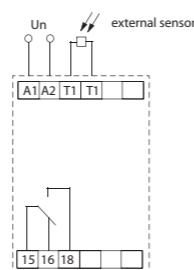

Symbol

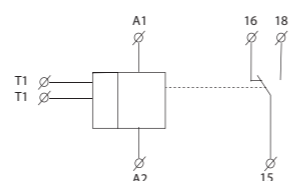

EAN code
SOU-3 /230 V: 8595188140560

Technical parameters SOU-3

Supply terminals:	L - N
Voltage range:	AC 230 V / 50 - 60 Hz
Tolerance of voltage range:	- 15 % .. +10 %
Input (apparent/loss):	max 6 VA / 0.7 W
Setting the scale level of lighting	by jumper J2

Function ☾ (twilight switch)	
- range 1:	1 ... 10 lx
- range 2:	10 ... 100 lx
- range 3:	100 ... 1.000 lx
Function ☀ (light switch)	
- range 1:	100 ... 1 000 lx
- range 2:	1 000 ... 10 000 lx
- range 3:	10 000 ... 100 000 lx
Setting function	by jumper J3
Level of light-slight:	0.1 ... 1 x range
Slight setting of light level:	potentiometer

Time delay t:	0 / 1 min. / 2 min.
Delay setting t:	by jumper J1

Output

Output contact:	1x NO- SPST (AgSnO ₂)
Current rating:	12 A / AC1
Switching output:	3000 VA / AC1, 384 W / DC
Peak current:	30 A / < 3 s
Switched voltage:	250 V AC / 24 V DC
Min.switching output:	500 mW
Mechanical life:	3 x 10 ⁷
Electrical life:	0.7 x 10 ⁵

Other information

Operation temperature:	-30 °C to +60 °C (-22 °F to 140 °F)
Storing temperature:	-30 °C to +70 °C (-22 °F to 158 °F)
Electrical strength:	4 kV (supply-output)
Operation position:	sensor-side down or on the sides
Protection degree:	IP 65
Overvoltage category:	III.
Pollution level:	2
Max. cable size (mm ²):	max. 1x 2.5, max. 2x 1.5 / with sleeve max. 1x 2.5 (AWG 12)
Suggested power-supply cable:	CYKY 3x 2.5 (CYKY 4x 1.5)
Dimensions:	96 x 62 x 34 mm (3.8" x 2.4" x 1.3")
Weight:	122 g (4.3 oz.)
Standards:	EN 60255-6, 61010-1

Device is standardly supplied with jumper L-15 (3-wire connection). For the correct function of device is necessary sensor-side down device mounting.

- Is used as control of the device on the basis of ambient light intensity.
- External version in IP65, box for mounting on the wall, front cover removable without screws.
- Built in high resolution light sensor.
- Two devices in one, function is set by jumper:
 - twilight switch – contact closes by decreasing of ambient light intensity, and opens by its increasing.
 - light switch – contact closes by increasing ambient light intensity, and opens by decreasing light intensity. Used for switching of devices by reaching of pre-set ambient light level, usually sun shine (pulling down the shutters or blinds, activation of solar panels) .
- 3 adjustable (by jumper) ranges of light level.
- 3 adjustable levels of time delay (for elimination of short-term fluctuations of light intensity – for short increases in light intensity).
- Supply voltage 230 V AC.
- Potential-free output contact 12 A / AC1 switching.

Description

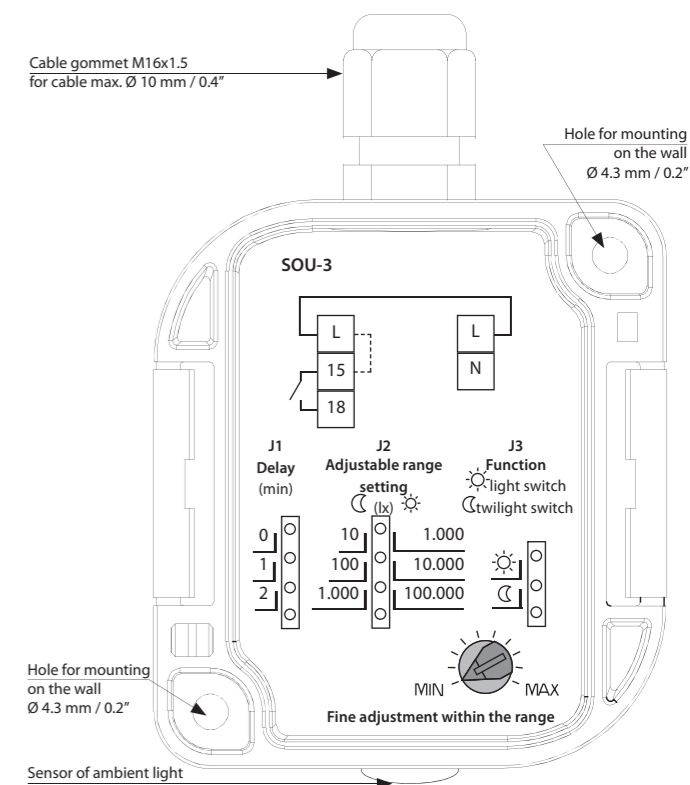

Connection

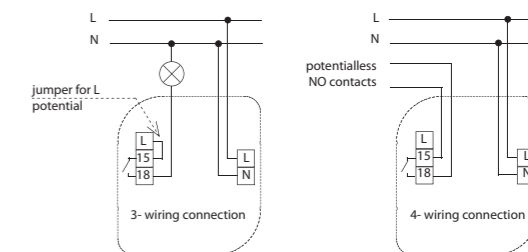

Function

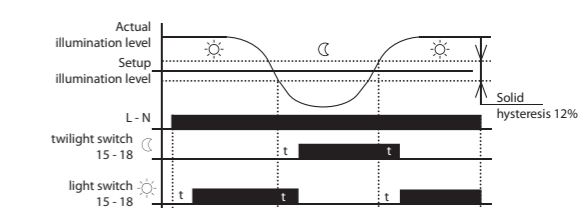



EAN code
 MR-41 /230 V: 8595188115889
 MR-41 /UNI: 8595188115896
 MR-42 /230 V: 8595188115902
 MR-42 /UNI: 8595188115919

	MR-41	MR-42
Number of functions:	1	2
Supply terminals:	A1 - A2	
Voltage range:	AC/DC 12 - 240 V (AC 50 - 60 Hz)	
Burden:	AC 0.17 - 3 VA / DC 0.1 - 1.2 W	AC 0.17 - 12 VA / DC 0.11 - 1.9 W
Voltage range:	AC 230 V / 50 - 60 Hz	
Consumption (apparent/loss):	AC max. 12 VA / 1.2 W	AC max. 12 VA / 1.9 W
Supply voltage tolerance:	-15 %; +10 %	
Supply indication:	green LED	
Output		
Number of contacts:	1x changeover / SPDT (AgSnO ₂)	2x changeover/ DPDT (AgSnO ₂)
Current rating:	16 A / AC1	
Breaking capacity:	4000 VA / AC1, 384 W / DC	
Inrush current:	30 A / < 3 s	
Switching voltage:	250 V AC1 / 24 V DC	
Min. breaking capacity DC:	500 mW	
Output indication:	red LED	
Mechanical life:	3x10 ⁷	
Electrical life (AC1):	0.7x10 ⁵	
Controlling		
Consumption of input:	AC 0.025 - 0.2 VA / DC 0.1 - 0.7 W (UNI), AC 0.53 VA (AC 230 V)	
Load between A2-ON/OFF:	Yes	
Control terminals:	A1 - ON/OFF	
Glow tubes connctions:	230 V - Yes / UNI - No	
Max. amount of glow lamps connected to controlling input:	UNI - glow lamps cannot be connected, 230 V - max. amount 5 pcs (measured with glow lamp 0.68 mA / 230 V AC)	
Impulse length:	min. 25 ms / max. unlimited	
Other data		
Operating temperature:	-20 °C to +55 °C (-4 °F to 131 °F)	
Storage temperature:	-30 °C to +70 °C (-22 °F to 158 °F)	
Electrical strength:	4 kV (supply - output)	
Operating position:	any	
Mounting:	DIN rail EN 60715	
Protection degree:	IP 40 from front panel / IP 20 terminals	
Overvoltage category:	III.	
Pollution degree:	2	
Max. cable size (mm ²):	solid wire max. 1x 2.5 or 2x 1.5 / with sleeve max. 1x 2.5 (AWG 12)	
Dimensions:	90 x 17.6 x 64 mm (3.5" x 0.7" x 2.5")	
Weight:	(UNI)-62 g (2.2 oz.), (230)-60 g (2.1 oz.)	(UNI)-89 g (3.1 oz.), (230)-85 g (2.99 oz.)
Standards:	EN 61810-1, EN 61010-1	

- Latching relays, controlled by buttons from several locations can replace three way switches or cross bar switches thanks to control by buttons (unlimited number, connected in parallel by 2 wires), installation gets more transparent and faster for mounting.
- Relays MR-41/UNI, MR-42/UNI memorize its last state even after supply failure. During the failure relay will turn off and after re-energizing will automatically turns on.
- **MR-41**
 - output contact: 1x changeover / SPDT 16 A
- **MR-42**
 - options - 2x parallel contacts or the other relay is latching
 - function selected via external jumper between B1 - B2
 - output contact: 2x changeover /DPDT 16 A
 - Supply voltage AC 230 V or AC/DC 12-240 V
- 1-MODULE version, DIN rail mounting, controlling by buttons

Connection

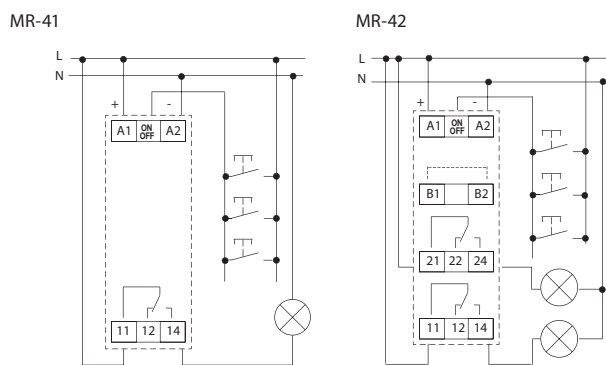

Function

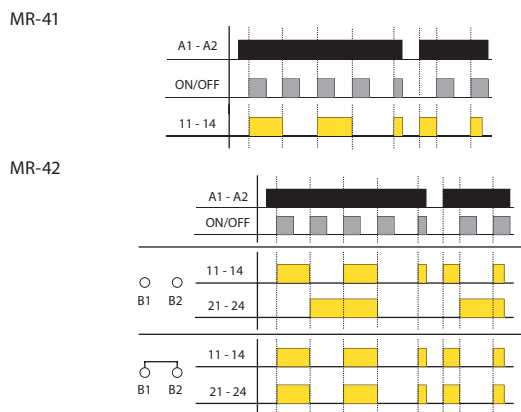

Symbol

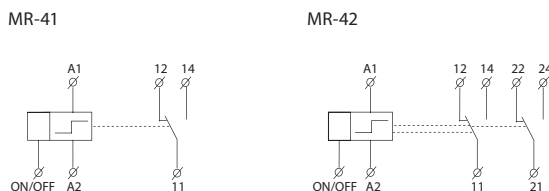



- EAN code
- USS-ZM: 8595188124577
 - USS-00: 8595188124614
 - USS-01: 8595188124621
 - USS-02: 8595188124638
 - USS-03: 8595188124645
 - USS-04: 8595188124652
 - USS-05: 8595188124669
 - USS-06/S: 8595188124676
 - USS-06/R: 8595188136372
 - USS-07: 8595188124683
 - USS-08: 8595188124690
 - USS-09: 8595188124706
 - USS-10: 8595188124331
 - USS-11: 8595188124348
 - USS-12: 8595188124355
 - USS-13: 8595188124362
 - USS-14: 8595188124898
 - USS-15: 8595188124379

Units			
NAME	CONNECTION	RATED CURRENT/ VOLTAGE (FOR SWITCHES) SUPPLY VOLTAGE (FOR SIGNALLING LIGHTS)	DESCRIPTION
USS-ZM	MODUL	-	Basic MODULE (housing with terminals and contacts)
USS-00		-	Blind flange
USS-01		6 A / 250 V AC	Switch
USS-02		8 A / 250 V AC	Alternation switch
USS-03		6 A / 250 V AC	Switch with central position
USS-04		6 A / 250 V AC	Switch + button with central position
USS-05		6 A / 250 V AC	Switching button with central position
USS-06/S		8 A / 250 V AC	NO switch
USS-06/R		8 A / 250 V AC	NC switch
USS-07		10 A / 250 V AC	Switch with glow lamp (red)
USS-08		10 A / 250 V AC	Switch with glow lamp (green)
USS-09		10 A / 250 V AC	Switch with glow lamp (yellow)
USS-10		A1-A2, AC 250 V A1-A3, AC/DC 24 V	Signalling LED (red)
USS-11		A1-A2, AC 250 V A1-A3, AC/DC 24 V	Signalling LED (green)
USS-12		A1-A2, AC 250 V A1-A3, AC/DC 24 V	Signalling LED (yellow)
USS-13		A1-A2, AC 250 V A1-A3, AC/DC 24 V	Signalling LED (white)
USS-14		A1-A2, AC 250 V A1-A3, AC/DC 24 V	Signalling LED flashing (red)
USS-15		A1-A2, AC 250 V A1-A3, AC/DC 24 V	Signalling LED (blue)

- Independent switch units designed for flexible controlling and switching of power circuits.
- USS - "Do It Yourself" = it is possible to "click into" different types of switches and signalling units into the basic module.
- Units are delivered as components and configured by the user.
- 15 types of units: switches, push buttons, signal lights of different colours including flashing lights units are replaceable also for future (for example when an application is changed, extended, etc...).
- It is possible to place up to two units into one MODULE (for example 2x switch, 2x signalling lights or combinations) = saves space in switchboard panels.
- 1-MODULE, DIN rail mounting.
- Operating temperature -20 °C to +55 °C (-4 °F to 131 °F).
- M3 screw with clamp terminals.



Switching units (01-09) are made by reputable French company - APEM. The quality of switch-buttons is guaranteed by long-term experiences in the field (from 1952) and by world-recognized certificates VDE and UL. Unique switching mechanism ensures long life of switching at constant parameters.

Make your own device USS - easy and intelligent solution!

BLIND FLANGE
Used to fill in an empty position in the front panel of the USS Module.
Color: Grey, RAL7035 (the same as the housing).
Unit: 00

SWITCHES, PUSH BUTTONS
They have a low uplift and a large fingerboard. High quality contacts, easy rock switch and large button area provide years of useful life.
Unit: 01-06

SWITCHES WITH GLOW LAMP
Switch and signalization in one unit. Signalization is carried out by a glow lamp in dolly including series resistance. It is possible to instal it for permanent indication or for an intermittennd by contact of the switch.
Colours: red, green, yellow.
Supply voltage of the signalling light: AC 250 V.
Unit: 07-09

SIGNALLING LIGHT
High luminescence SMD/LED that illuminates the entire button area surface. Input voltage can be either AC 230 V or AC/DC 24 V (output light may vary).
Red sig. light is delivered also in a flashing version. Unit: 14
Colours: red, green, yellow, white, blue
Unit: 10-15

Terminal connection Laser marking

Switches and buttons are marked by laser according to your request in case you order 50 pcs and more.

Example of an order:
USS - ZM
+ USS - 07
+ USS - 11

Max. number of symbols:

← 8
← 4
← 4
← 8

V Voltage

1 phase

AC/DC



HRN-41
(Hysteresis) monitoring DC and AC voltage 10-500 V, divided into 3 inputs and 3 ranges, 2 independent outputs 16 A, 2x time delay.



HRN-42
(Window) as HRN-41 but function WINDOW. Other functions applicable for HRN-41: faulty state memory, hysteresis, galv. separated supply.



HRN-34
as HRN-33 but in voltage range DC 6-30 V for monitoring battery circuits (6, 12, 24 V).



HRN-64
as HRN-63 but in voltage range DC 6-30 V for monitoring battery circuits (6, 12, 24 V).

AC



HRN-33
Supply and monitored voltage in range AC 48-276 V, 1x output for Umax and Umin adjustable level.



HRN-35
As HRN-33 but individual output for each level (Umax/Umin). Adjustable time delay to eliminate voltage peaks.



HRN-37
As HRN-33, but in voltage range AC 24-150 V.



HRN-63
Supply and monitored voltage in range AC 48-276 V, 1x output for Umax and Umin adjustable level.



HRN-67
as HRN-63, but in voltage range AC 24-150 V.

3 phase



HRN-55
Supply from all phases.



HRN-55N
Supply L1-N (monitors also disconnection of neutral wire). Time delay to eliminate peaks.



HRN-57
Supply from all phases.



HRN-57N
Supply L1-N (monitors also disconnection of neutral wire). Adjustable voltage level.



HRN-54
Supply from all phases.



HRN-54N
Supply L1-N (monitors also disconnection of neutral wire). All parameters adjustable by potentiometers.



HRN-56/120
Adjustable level Umin.



HRN-56/208
Adjustable level Umin.



HRN-56/240
Adjustable level Umin.



HRN-56/400
Adjustable level Umin.



HRN-56/480
Adjustable level Umin.



HRN-56/575
Adjustable level Umin.



HRN-43
Galvanically separated supply AC 230V, AC 400 or AC/DC 24V, memory, adjustable hysteresis and delay, 2 x independent output.



HRN-43N
Galvanically separated supply AC 230V, AC 400 or AC/DC 24V, memory, adjustable hysteresis and delay, 2 x independent output.



MPS-1
Optical signaling of three-phase network.

Hz Frequency



HRF-10
for monitoring the frequency of AC voltage. The monitored frequency 50/60/400 Hz is selected by a switch.

COS-φ Power factor



COS-1
monitors and scores power factor (phase shift between current and voltage cos φ) in 3phase/1phase circuits (motors, pumps etc.).

A Current

AC/DC



PRI-41
(Hysteresis) 3 inputs divided into 3 ranges (selectable by a switch).



PRI-42
(Window) as PRI-41 but function "WINDOW".

AC



PRI-32
Monitoring by current transformer (wire through an opening, galv. separated, without heat loss), adjust. current 1-20A, multivoltage AC 24-240 and DC 24V, output 8A changeover.



PRI-51
Monitoring of current by in-built transformer, 5 ranges (in versions 1/2/5/8/16A), range 5A is suitable for current transformer (X/5), supply and output as PRI-32, difference from PRI-32: direct monitoring and finer ranges (higher sensitivity) = higher accuracy in measuring.



PRI-52
For scanning the current up to 25 A. Long distance device diagnostics (black-out, incrementation of take-off) Priority relay. Supplying voltage AC 230 V Output 8A SPST switching over.



PRI-53
For monitoring the current in three-phase devices. Power supply: 24-240 V AC/DC, galvanically separated from the circuit of the monitored current 2 types depending on the strength of rated current In (1A, 5A).

Level



HRH-1
4 functions, advanced setting for various combinations, galvanically separated supply AC 230 V or AC/DC 24 V, 2 output contacts/2PDT 16A.



HRH-5
Simple version, 2 functions, galvanically separated supply voltage UNI 24. 240V AC/DC



HRH-6
Device monitors 5 levels by using six probes. Supply voltage: 12-24 V DC or galvanically separated 230 V AC.



HRH-6/S
Additional signalization to HRH-6 with 6 control lights on the front panel of device.



HRH-7
Suitable to operate in harsh conditions due to the high degree of protection IP65. Switch monitors the level changes in wells, reservoirs, tanks, tankers etc.

Level sets

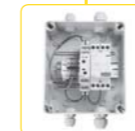

HRH-4
A set of level relay HRH-5 and a contactor VS425. For automatic operation 1-phase and 3-phase pumps. 2 function. IP55.



HRH-VS
Level sets are used to monitor fluid levels.



HRH-MS-1A
HRH-MS-1.6A
Level sets are used to monitor fluid levels.



HRH-MS-VS-2.5A
HRH-MS-VS-4A
HRH-MS-VS-6.3A
Level sets are used to monitor fluid levels.

Accessories



SHR
Level sensors
SHR-1 (M, N) - for monitoring flooding.
SHR-2 - for level detection.
SHR-3 - for demanding and industrial environment.

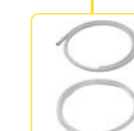

Cable, wire
D03V-F 3x0,75/3,2 - cable to SHR-1 and SHR-2 probes.
D05V-K 0,75/3,2 - wire to SHR-1 and SHR-2 probes.

Relays monitor voltage

Type	Design	Voltage	Secure variables							Setting			Description	Page
			Phases	Range	> U	< U	Failure	Phase sequence	Asymmetry	Delay	Hysteresis	Memory Errors		
HRN-33	1-M	from monitored	1	AC 48 - 276 V	•	•	x	x	x	•	x	x	For all types, the delay is adjustable from 0 - 10 seconds (to eliminate short-term outages or peaks). The lower voltage level (Umin) is set in % of the upper level (Umax).	68
HRN-34	1-M	from monitored	1	DC 6 - 30 V	•	•	x	x	x	•	x	x		
HRN-35	1-M	from monitored	1	AC 48 - 276 V	•	•	x	x	x	•	x	x		
HRN-37	1-M	from monitored	1	AC 24 - 150 V	•	•	x	x	x	•	x	x		
HRN-63	1-M	from monitored	1	AC 48 - 276 V	•	•	x	x	x	•	x	x		
HRN-64	1-M	from monitored	1	DC 6 - 30 V	•	•	x	x	x	•	x	x		
HRN-67	1-M	from monitored	1	AC 24 - 150 V	•	•	x	x	x	•	x	x		
HRN-41/230V HRN-41/110V HRN-41/400V HRN-41/24V	3-M	AC 230 V AC 110 V AC 400 V AC/DC 24 V	1	AC/DC 50 V AC/DC 160 V AC/DC 500 V	•	•	x	x	x	•	•	•	Second relay function (independent/parallel). Galvanically separated power supply from measuring inputs.	70
HRN-42/230V HRN-42/110V HRN-42/400V HRN-42/24V	3-M	AC 230 V AC 110 V AC 400 V AC/DC 24 V	1	AC/DC 50 V AC/DC 160 V AC/DC 500 V	•	•	x	x	x	•	•	•		
HRN-43/230V HRN-43/110V HRN-43/400V HRN-43/24V	3-M	AC 230 V AC 110 V AC 400 V AC/DC 24 V	3	AC 3 x 84 - 480 V	•	•	•	•	•	•	•	•	2 output relays, functions of the second relay may be selected (independent/parallel). Galvanically separated power supply.	74
HRN-43N/230V HRN-43N/110V HRN-43N/400V HRN-43N/24V	3-M	AC 230 V AC 110 V AC 400 V AC/DC 24 V	3	AC 3 x 48 - 276 V	•	•	•	•	•	•	•	•		
HRN-55	1-M	from monitored	3	AC 3 x 300 - 500 V	x	x	•	•	x	•	x	x	Power supply from all phases, i.e. the relay function is preserved even if one phase fails.	71
HRN-55N	1-M	from monitored	3	AC 3 x 172 - 287 V	x	x	•	•	x	•	x	x	Power supply L1-N, i.e. the relay also monitors the neutral wire interruption.	71
HRN-57	1-M	from monitored	3	AC 3 x 300 - 500 V	•	•	x	x	x	•	x	x	Power supply from all phases, i.e. the relay function is preserved even if one phase fails.	72
HRN-57N	1-M	from monitored	3	AC 3 x 172 - 287 V	•	•	x	x	x	•	x	x	Power supply L1-N, i.e. the relay also monitors the neutral wire interruption, replacement for HRN-52.	72
HRN-54	1-M	from monitored	3	AC 3 x 300 - 500 V	•	•	x	•	x	•	x	x	If the supply voltage falls below 60% of Un (OFF lower level), the relay will immediately disconnects with no delay. Power supply from all phases, i.e. the relay function is preserved even if one phase fails.	73
HRN-54N	1-M	from monitored	3	AC 3 x 172 - 287 V	•	•	x	•	x	•	x	x	If the supply voltage falls below 60% of Un (OFF lower level), the relay will immediately disconnects with no delay. Power supply L1-N, i.e. the relay also monitors the neutral wire interruption.	73
HRN-56/120 HRN-56/208 HRN-56/240 HRN-56/400	1-M	from monitored	3	AC 3 x 72 - 160 V AC 3 x 125 - 276 V AC 3 x 144 - 276 V AC 3 x 240 - 460 V	x	•	•	•	x	•	x	x	Thanks to the power supply from all three phases, the relay is operational even if one phase fails.	76
HRN-56/480 HRN-56/575	3-M	from monitored	3	AC 3 x 228 - 550 V AC 3 x 345 - 660 V	x	•	•	•	x	•	x	x		

Signal relays

Type	Design	Voltage	Phases	Range	> U	< U	Failure	Phase sequence	Asymmetry	Delay	Hysteresis	Memory Errors	Description	Page
MPS-1	1-M	from monitored	3	AC 3 x 50 - 253 V	x	•	•	•	x	x	x	x	Optical signaling of three-phase network.	77

Relay for frequency monitoring

Type	Design	Supply voltage	Secure variables				Setting				Description	Page	
			Phases	Frequency Range	Frequency >	Frequency <	Delay	Hysteresis	Frequency >	Frequency <			
HRF-10	3-M	AC 161 - 346 V	1	40 - 60 Hz 48 - 72 Hz 320 - 480 Hz	•	•	•	•	•	•	•	Switchable ranges of rated frequency .	78

Relay for factor cos-φ monitoring

Type	Design	Supply voltage	Secure variables				Setting			Description	Page	
			Phases	cos φ range	> cos φ	< cos φ	Delay	Hysteresis	Memory Errors			
COS-1/230V COS-1/110V COS-1/400V COS-1/24V	3-M	AC 230 V AC 110 V AC 400 V AC/DC 24 V	3	0.1 - 0.99	•	•	•	•	•	•	Two output relays, one independent relay for each level Galvanically separated power supply.	79

Relay for current monitor

Type	Design	Supply voltage	Secure variables				Setting					Description	Page
			Phases	Range	> I	< I	Delay	Hysteresis	Memory Errors	> I	< I		
PRI-32	1-M	AC 24-240 V DC 24 V	1	AC 1-20 A	•	x	x	x	x	•	x	Exceeding the current value - the current flowing through the monitored conductor must not exceed 100 A even on a short-term basis.	80
PRI-41/230V PRI-41/24V	3-M	AC 230 V AC/DC 24 V	1	AC/DC 1.6 A AC/DC 5 A AC/DC 16 A	•	•	•	•	•	•	•	The adjustable delay for elimination of short-term outages and peaks for every level. Galvanically separated power supply.	84
PRI-42/230V PRI-42/24V	3-M	AC 230 V AC/DC 24 V	1	AC/DC 1.6 A AC/DC 5 A AC/DC 16 A	•	•	•	•	•	•	•	The adjustable delay for elimination of short-term outages and peaks for every level. Galvanically separated power supply.	84
PRI-51/0.5 PRI-51/1 PRI-51/2 PRI-51/5 PRI-51/8 PRI-51/16	1-M	AC 24-240 V DC 24 V	1	AC 0.05 - 0.5 A AC 0.1 - 1 A AC 0.2 - 2 A AC 0.5 - 5 A AC 0.8 - 8 A AC 1.6 - 16 A	•	x	•	x	x	•	x	May be used for scanning the current from the current transformer - up to 600A. Power supply is galvanically separated from the measured current.	81
PRI-52	1-M	AC 230 V	1	AC 0.5 - 25 A	•	x	•	x	x	•	x	May be used for scanning the current from the external current transformer - up to 600A.	82
PRI-53/1 PRI-53/5	6-M	AC/DC 24-240 V	3	AC 3 x 0.4 - 1.2 A AC 3 x 2 - 6 A	•	•	•	x	x	•	•	Monitors the drop in the strength of current below the preset value. Monitors exceeding the preset value.	83

Level switches

Type	Design	Supply voltage	Secure variables		Setting			Description	Page
			Leve max.	Leve min.	Delay	Sensitivity Probe	Function		
HRH-1/230V HRH-1/110V HRH-1/400V HRH-1/24V	3-M	AC 230 V AC 110 V AC 400 V AC/DC 24 V	•	•	•	•	•	Sensitivity adjustable by potentiometer. Galvanically separated power supply.	86
HRH-4/230V HRH-4/24V	set	AC 230 V AC/DC 24 V	•	•	•	•	•	Unit with no protection devices - adequate protection element needs to be integrated before the unit. Ingress protection of the assembly is IP55.	94
HRH-5	1-M	AC/DC 24-240 V	•	•	•	•	•	Measuring the frequency of 10 Hz will protect liquid from polarisation and measuring probes from increased oxidation. Galv. separated power supply.	85
HRH-6/AC HRH-6/DC	box IP65	AC 230 V AC/DC 12-24V	•	•*	•	•	•	* devices mainly designated for monitoring water level in fire-engine tanks.	88
HRH-7	box IP65	AC/DC 24-240 V	•	•	•	•	•	suitable to work in harsh conditions due to the high degree of protection IP65.	90
HRH-VS	set	230 / 400V AC/DC (AC 50-60 Hz)	•	•	•	•	•	Level sets placed in the control cabinet with IP65 protection (protected against dust and spraying water) where everything is already connected.	92
HRH-MS-1A HRH-MS-1.6A	set	230 / 400V AC/DC (AC 50-60 Hz)	•	•	•	•	•		
HRH-MS-VS-2.5A HRH-MS-VS-4A HRH-MS-VS-6.3A	set	230 / 400V AC/DC (AC 50-60 Hz)	•	•	•	•	•		



EAN code
 HRN-33: 8595188115636
 HRN-34: 8595188115643
 HRN-35: 8595188115650
 HRN-37: 8595188130615
 HRN-63: 8595188130622
 HRN-64: 8595188130639
 HRN-67: 8595188130646

Technical parameters	HRN-33 / HRN-63	HRN-34 / HRN-64	HRN-35	HRN-37 / HRN-67
Supply and measuring				
Terminals:	A1 - A2	A1 - A2	A1 - A2	A1 - A2
Voltage range:	AC 48 - 276 V /		AC 48 - 276 V / AC 24-150 V /	
Burden:	50-60Hz	DC 6 - 30 V	50-60Hz	50-60Hz
Upper level (Umax):	AC max. 1.2 VA	DC max. 1.2 VA	AC max. 1.2 VA	AC max. 1.2 VA
Bottom level (Umin):	AC 160 - 276 V	DC 18 - 30 V	AC 160 - 276 V	AC 80-150 V
Max. permanent:	30-95 % Umax	35-95 % Umax	30-95 % Umax	30-95 % Umax
Peak overload <1ms:	AC 276 V	DC 36 V	AC 276 V	AC 276 V
Time delay:	AC 290 V	DC 50 V	AC 290 V	AC 290 V
Accuracy	adjustable 0 - 10 s			
Setting accuracy (mechanical):				
	5 %			
Repeat accuracy:				
	<1 %			
Dependence on temperature:				
	< 0.1 % / °C (°F)			
Tolerance of limit values:				
	5 %			
Hysteresis (from fault to normal):				
	2 - 6 % of adjusted value (only HRN-33, HRN-34, HRN-35, HRN-37)			
Output				
Number of contacts:	1x changeover / SPDT (AgNi / Silver Alloy)	1x changeover / SPDT (AgNi / Silver Alloy)	1x changeover / for each level of voltage, (AgNi)	1x changeover / SPDT (AgNi / Silver Alloy)
Current rating:	16 A / AC1			
Breaking capacity:	4000 VA / AC1, 384 W / DC			
Inrush current:	30 A / < 3 s			
Switching voltage:	250 V AC1 / 24 V DC			
Min. breaking capacity DC:	500 mW			
Output indication:	red / green LED			
Mechanical life:	3x10 ⁷			
Electrical life (AC1):	0.7x10 ⁵			
Other information				
Operating temperature:	-20 °C to 55 °C (-4 °F to 131 °F)			
Storage temperature:	-30 °C to 70 °C (-22 °F to 158 °F)			
Electrical strength:	4 kV (supply - output)			
Operating position:	any			
Mounting:	DIN rail EN 60715			
Protection degree:	IP40 from front panel, IP20 terminals			
Overvoltage category:	III.			
Pollution degree:	2			
Max. cable size (mm ²):	solid wire max. 1x 2.5 or 2x 1.5, with sleeve max. 1x 2.5 (AWG 12)			
Dimensions:	90 x 17.6 x 64 mm (3.5" x 0.7" x 2.5")			
Weight:	61 g (2.2 oz.)	73 g (2.6 oz.)	85 g (3 oz.)	61 g (2.2 oz.)
Standards:	EN 60255-6, EN 61010-1			

- It serves to control supply voltage for appliances sensitive to supply tolerance, protection of the device against under/over voltage.
- HRN-3x is band voltage relay, HRN-6x is over/under voltage relay. For difference - see graph of function.
- **HRN-33, HRN-63**
 - monitors voltage in range AC 48 - 276 V
 - U max and U min can be monitored independently
- **HRN-34, HRN-64**
 - like HRN-33, but voltage range is DC 6 - 30 V
 - monitoring of battery circuits (12, 24 V)
- **HRN-35**
 - like HRN-33, but independent output relays for each voltage level
 - switching of other loads possible
- **HRN-37, HRN-67**
 - like HRN-33, monitors voltage in range AC 24 - 150 V
 - it is possible to monitor level of overvoltage and undervoltage independently
- Adjustable time delay for all types is 0 - 10 s (to eliminate short voltage drops or peaks).
- Voltage Umin adjusted as % of Umax.
- 3-state indication - LEDs indicating normal state and 2 fault states.
- Supply from monitored voltage (monitors level of its own supply).
- 1-MODULE, DIN rail mounting.

Description

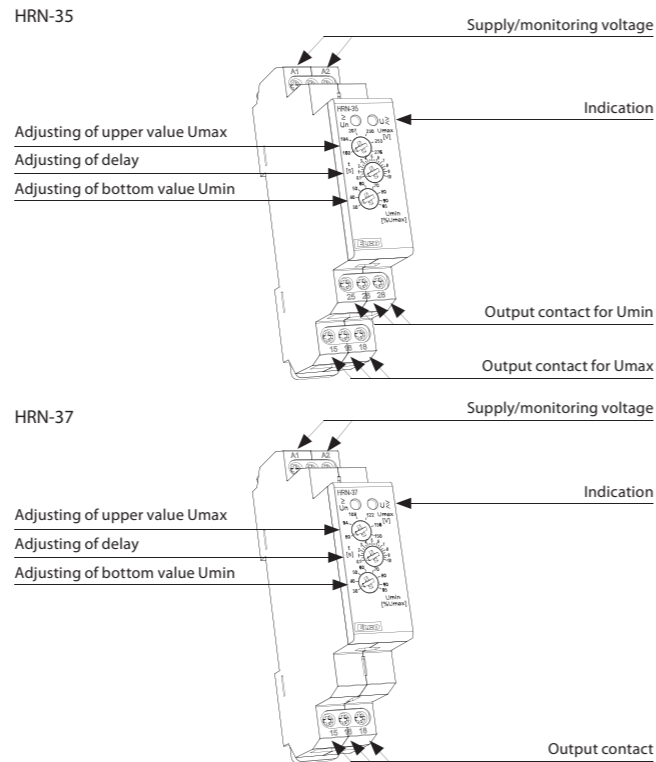

Connection

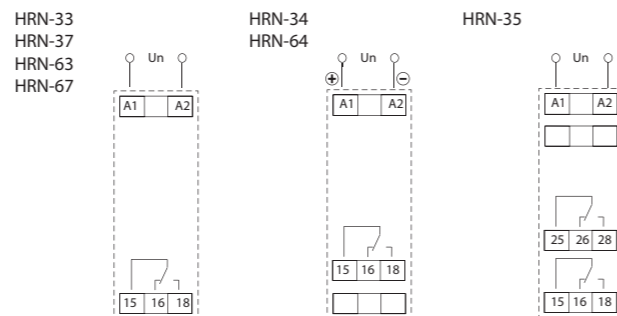

Function HRN-33, 34, 35, 37 (band voltage relay)

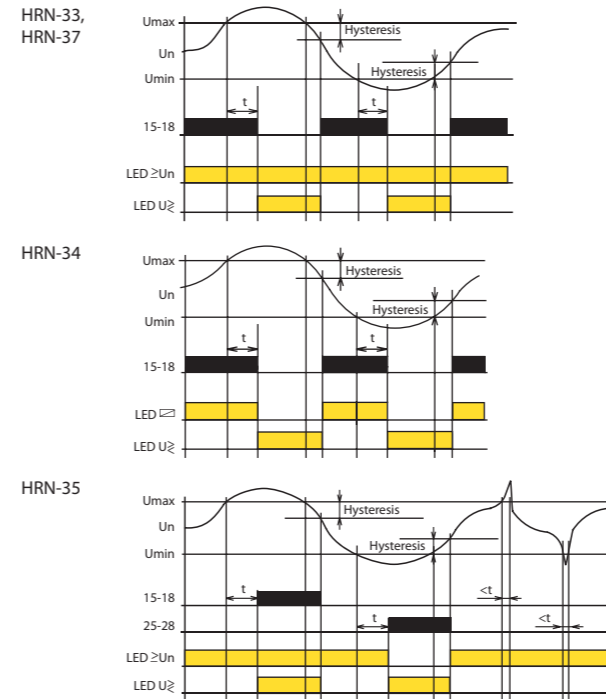

Function HRN-63, 64, 67 (over/under voltage relay)

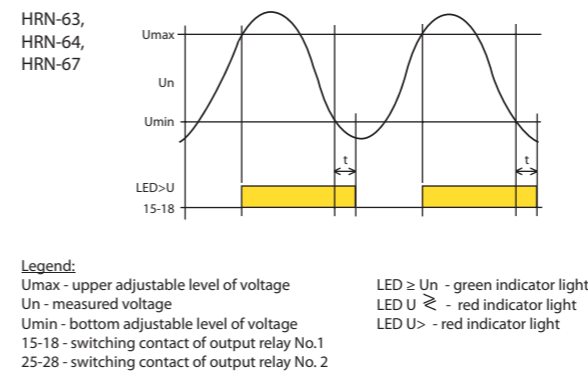

Monitoring relay series HRN-3x monitors level of voltage in single - phase circuits. Monitored voltage serves also as supply voltage. It is possible to set two independent (all occurrences) levels of voltage, when exceeded the output is activated. HRN-33 and HRN-34 - in normal state the output relay is permanently switched. It switches off when there is a limit settings. This combination of linkage of the output relay is advantageous when the full failure of supply (monitored) voltage is considered to be a faulty state in the same way as a decrease of voltage within the set level. Output relay is in both situations always switched off. Differently HRN-35 version uses independent relay for each level, in normal state it is switched off. If the upper level is exceeded (for example overvoltage) 1 relay switches on, when the bottom level (e.g. undervoltage) is exceeded 2 relay switches. It is thus possible to see the particular faulty state. To eliminate short peaks in the main time delay, which is possible to be set in range 0 - 10 s, is used. It functions when changing from normal to faulty state and prevents unavailing pulsation of the output relay caused by parasitive peaks. Time delay doesn't apply when changing from faulty to normal state, but hysteresis (1-6% depends on the voltage setting) apply. Thanks to changeover contacts it is possible to get other configurations and functions according to actual requirements of the application.

Monitoring relay line HRN-6x serves to monitor levels of voltage in single-phase or DC circuits. Monitored voltage is in the same time also supply voltage. It is possible to set two independent levels of voltage. When Umax is exceeded, output is activated. In case voltage level falls below Umin, output is deactivated. This combination is advantageous when full absence of supply voltage is understood as faulty state, as well as voltage drop within the set level. To eliminate short voltage peaks in the main there is time delay which can be set in a range of 0-10 sec. Such delay applies in case of going from overvoltage to undervoltage. In case of returning from undervoltage to overvoltage this delay doesn't apply. Thanks to changeover output contacts it is possible to reach various configurations and functions according to requirements or an application.

Symbol

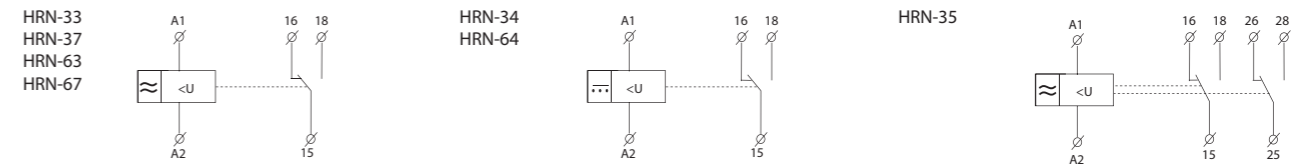

Indication LED

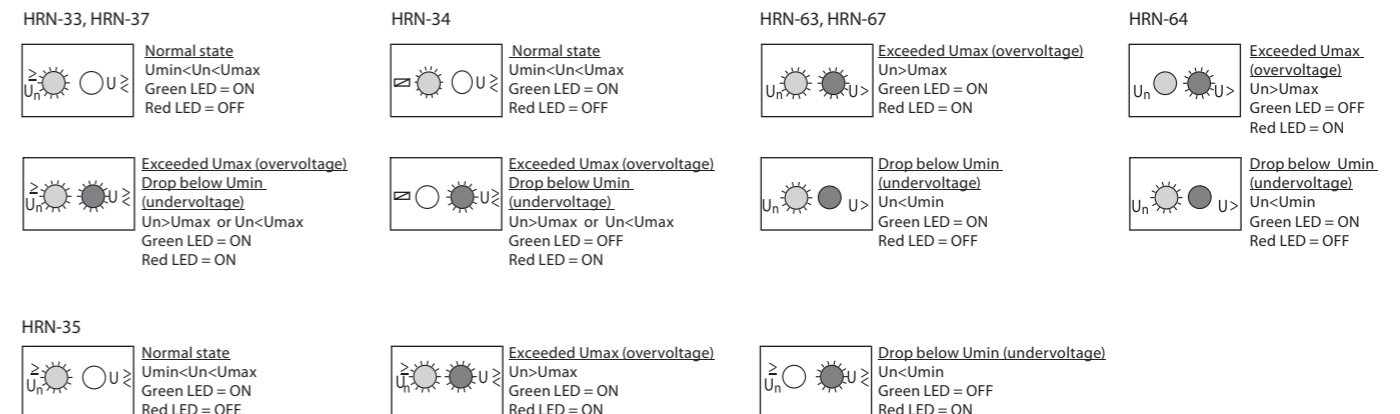



EAN code
 HRN-41 /230V: 8595188140409
 HRN-41 /400V: 8595188140423
 HRN-41 /24V: 8595188140416
 HRN-42 /230V: 8595188140447
 HRN-42 /24V: 8595188140454

Technical parameters	HRN-41	HRN-42	
Supply			
Supply terminals:	A1 - A2		
Voltage range:	AC 230 V, AC 400 V or AC/DC 24 V (AC 50-60Hz)		
Burden max.:	2.5 W / 5 VA (AC 230 V, AC 400 V), 1.4 W / 2 VA (AC/DC 24 V)		
Supply voltage tolerance:	-15 %; +10 %		
Measuring			
Ranges:*	AC/DC 10 - 50 V (AC 50 - 60 Hz)	AC/DC 32 - 160 V (AC 50 - 60 Hz)	AC/DC 100 - 500 V (AC 50 - 60 Hz)
Terminals:	C - B1	C - B2	C - B3
Input resistance:	212 kΩ	676 kΩ	2.12 MΩ
Max. permanent overload:	100 V	300 V	600 V
Peak overload <1ms:	250 V	700 V	1 kV
Time delay for Umax:	adjustable 0-10 s		
Time delay for Umin:	adjustable 0-10 s		
Accuracy			
Setting accuracy (mechanical):	5 %		
Repeat accuracy:	<1 %		
Dependence on temperature:	< 0.1 % / °C (°F)		
Tolerance of limit values:	5 %		
Hysteresis (from fault to normal):	selectable 5 % / 10 % from range		
Output			
Number of contacts:	2x changeover / SPDT (AgNi / Silver Alloy)		
Current rating:	16 A / AC1		
Breaking capacity:	4000 VA / AC1, 384 W / DC		
Inrush current:	30 A / < 3 s		
Switching voltage:	250 V AC1 / 24 V DC		
Min. breaking capacity DC:	500 mW		
Output indication:	yellow LED		
Mechanical life:	3x10 ⁷		
Electrical life (AC1):	0.7x10 ⁵		
Other information			
Operating temperature:	-20 °C to +55 °C (-4 °F to 131 °F)		
Storage temperature:	-30 °C to +70 °C (-22 °F to 158 °F)		
Electrical strength:	4 kV (supply - output)		
Operating position:	any		
Mounting:	DIN rail EN 60715		
Protection degree:	IP40 from front panel / IP20 terminals		
Overvoltage category:	III.		
Pollution degree:	2		
Max. cable size (mm ²):	solid wire max. 1x 2.5 or 2x 1.5 / with sleeve max. 1x 1.5 (AWG 12)		
Dimensions:	90 x 52 x 65 mm (3.5" x 2" x 2.6")		
Weight:	246 g (230 V, 400 V) (8.7 oz.), 146 g (24 V) (5.1 oz.)		
Standards:	EN 60255-6, EN 61010-1		

* Only one of the inputs can be connected.

- Relay designed for monitoring DC and AC voltage in three ranges.
- The relay controls the size of the voltage in two independent levels (Umin, Umax).
- Setting the monitored level Umax (in % of range.)
- Setting the monitored level Umin (in % of range - for HRN-42 -function WINDOW), (in % of the set upper limit - for HRN-41 - function HYSTERESIS).
- Adjustable function "MEMORY".
- Function of second relay (independently / in parallel).
- Adjustable delay for eliminating short-term outages and surges for every level independently.
- Galvanically separated power supply from monitoring inputs.
- Output contact 2x switching 16 A / 250 V AC1 for each monitored voltage level.
- In 3-MODULE design, fixing to DIN rail.

Description

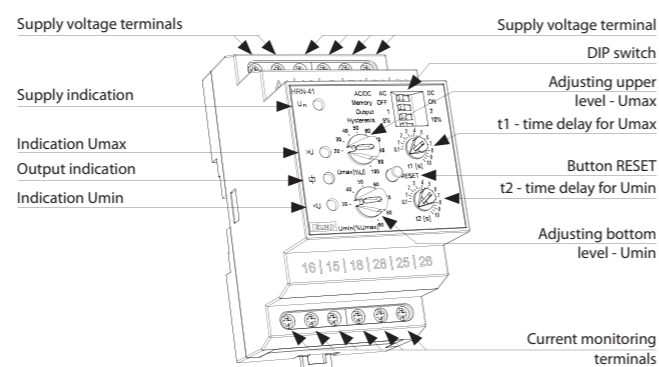

Function

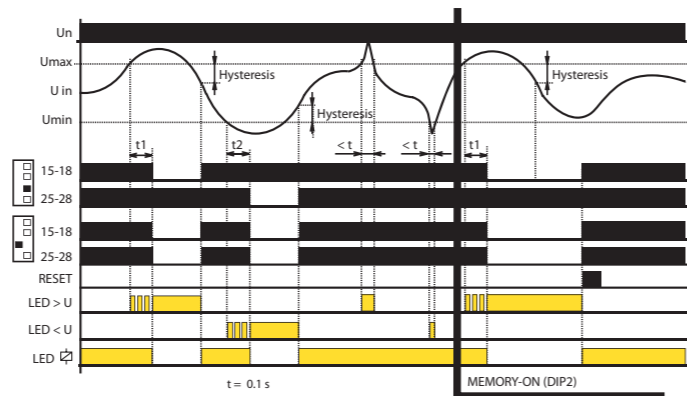

Connection

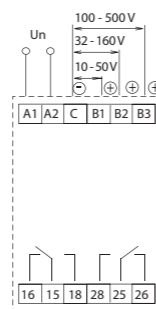

Symbol

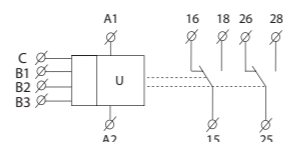

- if the value of the monitored voltage is in the zone between the set upper and lower levels, the status OK occurs - both relays are closed and the yellow LED illuminates. If the value of the monitored voltage is outside the set limits (> Umax or < Umin), an error state occurs.

- when moving to an error state $U > U_{max}$, it times the delay t_1 and a red LED $> U$ simultaneously flashes. After the t_1 time elapses, the red LED $> U$ illuminates and the relevant relay opens.

- when moving to an error state $U < U_{min}$, it times the delay t_2 and a red LED $< U$ simultaneously flashes. After the time t_2 elapses, the red LED $< U$ illuminates and the relevant relay opens.

- when moving from the error status to the OK status, the relevant red LED immediately goes out, and the corresponding relay closes.



EAN code
 HRN-55: 8595188137225
 HRN-55N: 8595188137232

Technical parameters	HRN-55	HRN-55N
Monitoring terminals:	L1, L2, L3	L1, L2, L3, N
Supply terminals:	L1, L2, L3	L1, N
Voltage:	3x 400 V / 50 Hz	3x 400 V / 230 V / 50 Hz
Level Umax:	125 % Un	
Level Umin:	75 % Un	
Burden:	max. 2 VA	
Hysteresis:	2 %	
Max. permanent:	AC 3x 460 V	AC 3x 265 V
Peak overload <1ms:	AC 3x 500 V	AC 3x 288 V
Time delay T1:	max. 500 ms	
Time delay T2:	adjustable 0.1 - 10 s	
Output		
Number of contacts:	1x changeover / SPDT (AgNi / Silver Alloy)	
Current rating:	8 A / AC1	
Breaking capacity:	2500 VA / AC1, 240 W / DC	
Inrush current:	10 A	
Switching voltage:	250 V AC1 / 24 V DC	
Min. breaking capacity DC:	500 mW	
Output indication:	red LED	
Mechanical life:	1x10 ⁷	
Electrical life (AC1):	1x10 ⁵	
Other information		
Operating temperature:	-20 °C to 55 °C (-4 °F to 131 °F)	
Storage temperature:	-30 °C to 70 °C (-22 °F to 158 °F)	
Electrical strength:	4 kV (supply - output)	
Operating position:	any	
Mounting:	DIN rail EN 60715	
Protection degree:	IP40 from front panel / IP10 terminals	
Overvoltage category:	III.	
Pollution degree:	2	
Max. cable size (mm ²):	solid wire max. 2x 2.5 or 1x 4 with sleeve max. 1x 2.5 or 2x 1.5 (AWG 12)	
Dimensions:	90 x 17.6 x 64 mm (3.5 x 0.7 x 2.5")	
Weight:	67 g (2.36 oz.)	66 g (2.3 oz.)
Standards:	EN 60255-6, EN 61010-1	

Function description

Relay in 3-phase main monitors correct phase sequence and failure of any phase. Green LED is permanently ON and indicates presence of power supply voltage. In case of phase failure or exceeding voltage level red LED flashes and relay breaks. When changing to faulty state, time delay applies. Time delay setting is set by a potentiometer on front panel of the device. In case of incorrect phase sequence red LED shines permanently and relay is open. In case supply voltage falls below 60 % Un (OFF lower level) relay immediately opens with no delay and faulty state is indicated by red LED.

HRN-55 - thanks to supply form all phases, this relay is able to stay operational also if one phase is out.

HRN-55N - supply L1-N, means that relay monitor also failure in neutral wire.

- Relay monitors phase sequence and failure, exceeding of monitored voltage in 3 phase main.
- HRN-55 - supply from all phases, which means that function of relay is applicable also if one phase fails.
- HRN-55N - supply L1-N, it means that relay also monitors break of neutral point.
- Fixed delay T1 (500 ms) and adjustable delay T2 (0.1 - 10 s).
- Faulty state is indicated by LED and output contact of relay is OFF.
- Output contact: 1x changeover / SPDT 16 A / 250 V AC1.
- 1-MODULE, DIN rail mounting.

Description

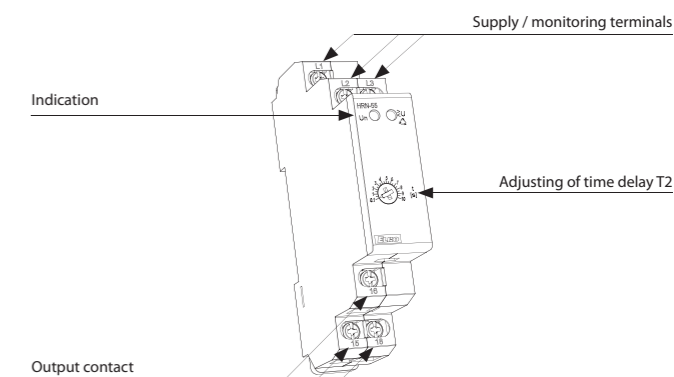

Function

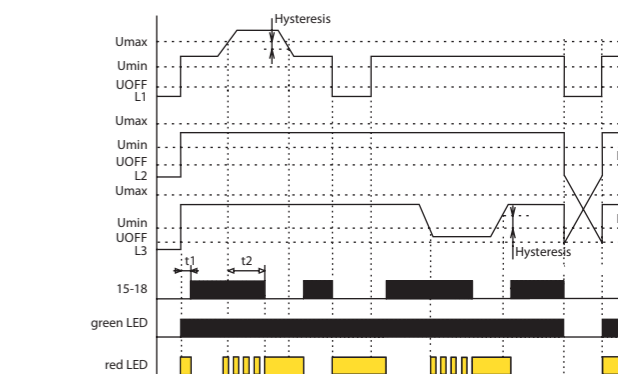

Connection

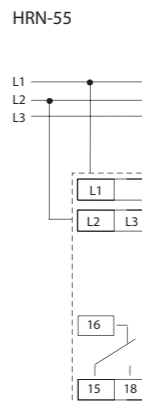

Symbol

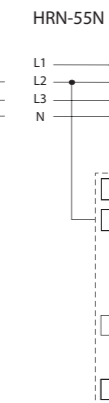

Symbol

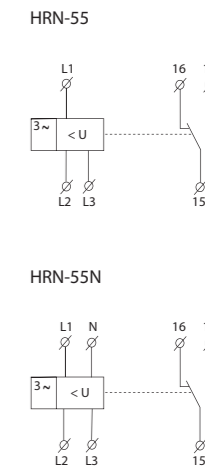

Symbol

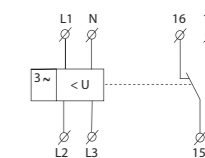



EAN code
HRN-57: 8595188137256
HRN-57N: 8595188137249

Technical parameters	HRN-57	HRN-57N
Monitoring terminals:	L1, L2, L3	L1, L2, L3, N
Supply terminals:	L1, L2, L3	L1, N
Voltage:	3x 400 V / 50 Hz	3x 400 V / 230 V / 50 Hz
Level Umax:	105 - 125 % Un	
Level Umin:	75 - 95 % Un	
Burden:	max. 2 VA	
Hysteresis:	2 %	
Max. permanent overload:	AC 3x 460 V	AC 3x 265 V
Peak overload <1ms:	AC 3x 500 V	AC 3x 288 V
Time delay T1:	max. 500 ms	
Time delay T2:	adjustable 0.1-10 s	

Output		
Number of contacts:	1x changeover / SPDT (AgNi / Silver Alloy)	
Current rating:	8 A / AC1	
Breaking capacity:	2500 VA / AC1, 240 W / DC	
Inrush current:	10 A	
Switching voltage:	250 V AC1 / 24 V DC	
Min. breaking capacity DC:	500 mW	
Output indication:	red LED	
Mechanical life:	1x10 ⁷	
Electrical life (AC1):	1x10 ⁵	

Other information		
Operating temperature:	-20 °C to 55 °C (-4 °F to 131 °F)	
Storage temperature:	-30 °C to 70 °C (-22 °F to 158 °F)	
Electrical strength:	4 kV (supply - output)	
Operating position:	any	
Mounting:	DIN rail EN 60715	
Protection degree:	IP40 from front panel / IP10 terminals	
Overvoltage category:	III.	
Pollution degree:	2	
Max. cable size (mm ²):	solid wire max. 2x 2.5 or 1x 4 / with sleeve max. 1x 2.5 or 2x 1.5 (AWG 12)	
Dimensions:	90 x 17.6 x 64 mm (3.5" x 0.7" x 2.5")	
Weight:	68 g (2.4 oz.)	66 g (2.3 oz.)
Standards:	EN 60255-6, EN 61010-1	

Function description

Relay in 3-phase main monitors size of phase voltage. It is possible to set two independent voltage levels and thus it is possible to set two independent voltage levels and monitor e.g. undervoltage and overvoltage independently. In normal state when voltage is within set levels, output relay is closed and red LED shines. In case supply voltage falls below 60 % Un (U_{OFF} lower level) relay immediately breaks without delay and faulty state is indicated by red LED. In case voltage exceeds or falls below the set levels, output relay breaks and red LED shines (LED indicates faulty state - flashes when timing). In case timing is in progress and faulty state is indicated, timing is immediately stopped.

- It serves to monitor voltage in a switchboard, protection of devices in 3-phase main.
- It monitors value of voltage in 3-phase main.
- It is possible to set upper and lower level independently.
- Adjustable time delay eliminates short voltage peaks and failures in the main.
- The device is supplied from monitored voltage.
- Faulty state is indicated by red LED and by breaking output relay contact.
- Output contact 1x changeover / SPDT 8 A / 250 V AC1.
- Relay doesn't monitor phase sequence.
- HRN-57 - supply from all phases, means that relay is functional also in case of failure in one phase.
- HRN-57N - supply L1-N, means that relay monitors also failure of neutral wire.
- 1-MODULE, DIN rail mounting.

Description

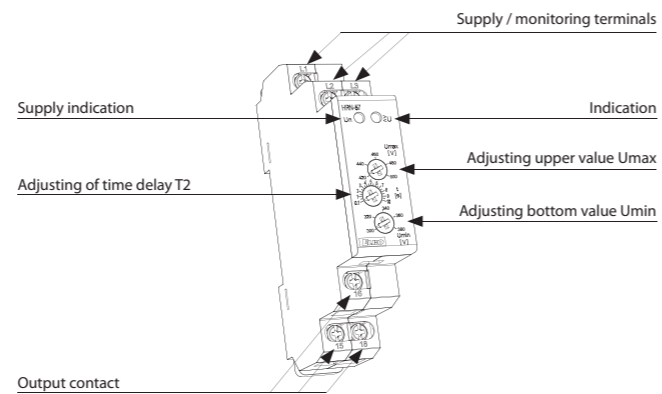

Function

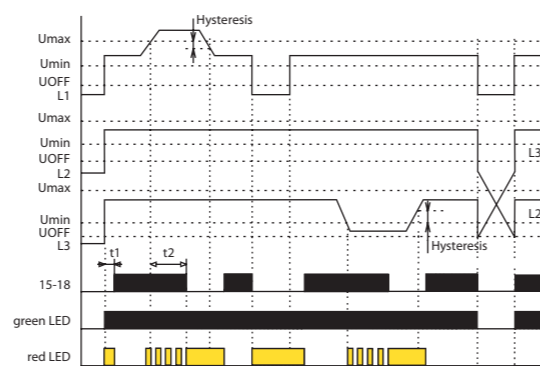

Connection

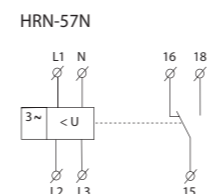
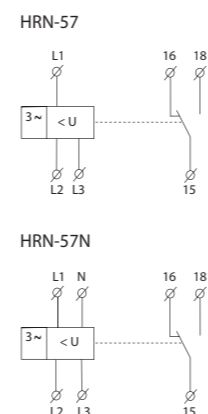
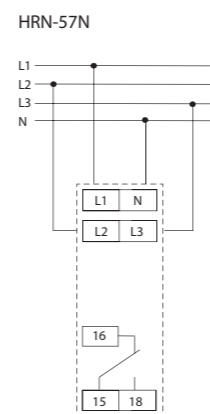
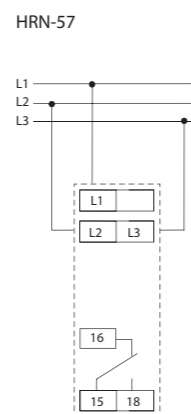

EAN code
HRN-54: 8595188137201
HRN-54N: 8595188137218

Technical parameters	HRN-54	HRN-54N
Supply and measuring:	L1, L2, L3	L1, L2, L3, N
Supply terminals:	L1, L2, L3	L1, N
Supply / measured voltage:	3x 400 V / 50 Hz	3x 400 V / 230 V / 50 Hz
Level Umax:	105 - 125 % Un	
Level Umin:	75 - 95 % Un	
Burden:	max. 2 VA	
Hysteresis:	2%	
Max. permanent overload:	AC 3x 460 V	AC 3x 265 V
Peak overload <1ms:	AC 3x 500 V	AC 3x 288 V
Time delay T1:	max. 500 ms	
Time delay T2:	adjustable 0.1-10 s	

Output		
Number of contacts:	1x changeover / SPDT (AgNi / Silver Alloy)	
Current rating:	8 A / AC1	
Breaking capacity:	2500 VA / AC1, 240 W / DC	
Inrush current:	10 A	
Switching voltage:	250 V AC1 / 24 V DC	
Min. breaking capacity DC:	500 mW	
Indication of state:	red LED	
Mechanical life:	1x10 ⁷	
Electrical life (AC1):	1x10 ⁵	

Other information		
Operating temperature:	-20 °C to 55 °C (-4 °F to 131 °F)	
Storage temperature:	-30 °C to 70 °C (-22 °F to 158 °F)	
Electrical strength:	4 kV (supply - output)	
Operating position:	any	
Mounting:	DIN rail EN 60715	
Protection degree:	IP40 from front panel / IP10 terminals	
Overvoltage category:	III.	
Pollution degree:	2	
Max. cable size (mm ²):	solid wire max. 2x 2.5 or 1x 4 / with sleeve max. 1x 2.5 or 2x 1.5 (AWG 12)	
Dimensions:	90 x 17.6 x 64 mm (3.5 x 0.7 x 2.5")	
Weight:	69 g (2.43 oz.)	67 g (2.36 oz.)
Standards:	EN 60255-6, EN 61010-1	

Function description

Relay in 3-phase main monitors size of phase voltage. It is possible to set two independent voltage levels and thus it is possible to set two independent voltage levels and monitor e.g. undervoltage and overvoltage independently. In normal state when voltage is within set levels, output relay is closed and red LED shines. In case voltage exceeds or falls below the set levels, output relay opens and red LED shines (LED indicates faulty state - flashes when timing). In case supply voltage falls below 60 % Un (U_{OFF} lower level) relay immediately opens without delay and faulty state is indicated by red LED. In case timing is in progress and faulty state is indicated, timing is immediately stopped.

- It serves to monitor voltage, phase failure and sequence in switchboards, protection of devices in 3-phase mains.
- It is possible to set upper and lower level of monitoring voltage.
- Adjustable time delay eliminates short voltage peaks and failures in the main.
- Supplied from monitored voltage.
- Faulty state is indicated by red LED and by opening of output relay contact.
- Output contact 1x changeover / SPDT 8 A / 250 V AC1.
- In case supply voltage falls below 60 %Un (U_{OFF} lower level) relay immediately opens without delay.
- HRN-54 - supply from all phases which means that relay is functional also in case when one phase is faulty.
- HRN-54N - supply L1-N, means that relay monitors also failure of neutral wire.
- 1-MODULE, DIN rail mounting.

Description

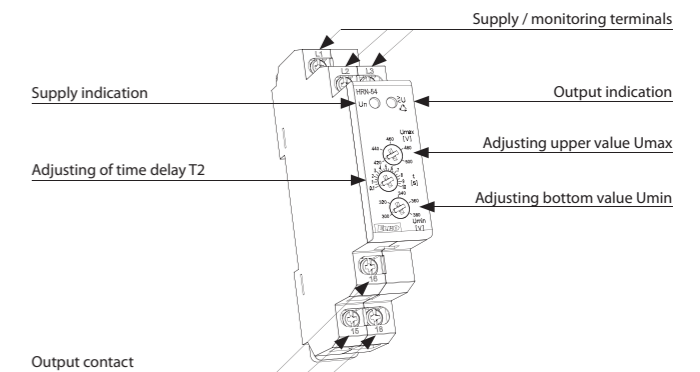

Function

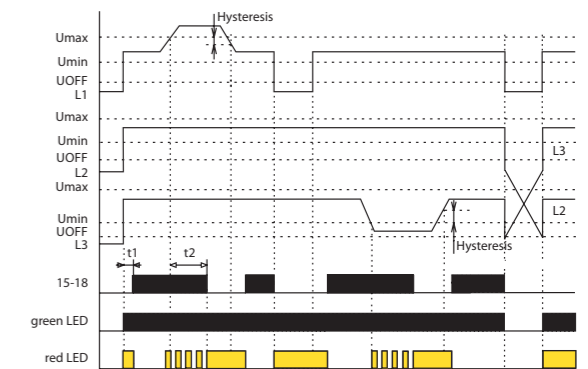

Connection

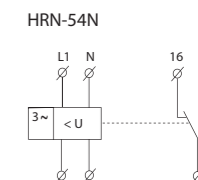
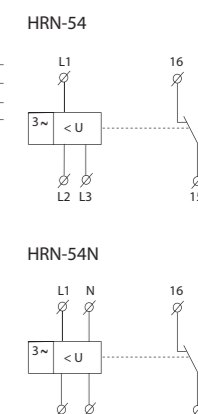
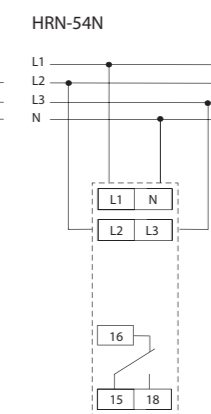



EAN code
 HRN-43 /230V: 8594030337660
 HRN-43 /400V: 8595188121316
 HRN-43 /24V: 8594030338087
 HRN-43N /230V: 8594030338216
 HRN-43N /400V: 8595188120258
 HRN-43N /24V: 8594030338094

Technical parameters	HRN-43	HRN-43N
Supply		
Supply terminals:	A1 - A2	
Voltage range:	AC 230 V, AC 400 V, AC/DC 24 V / (AC 50 - 60 Hz)	
Burden:	max. 4.5 VA	
Supply voltage tolerance:	-15 %; +10 %	
Measuring circuit		
Nominal voltage:	3x 400 V / 50 Hz	3x 400 V / 230 V / 50 Hz
Terminals:	L1, L2, L3	L1, L2, L3, N
Upper level Umax:	240 - 480 V	138 - 276 V
Bottom level Umin:	35 - 99 % Umax	
Max. permanent overload:	3x 480 V	
Hysteresis:	adjustable 5 % or 10 % of set value	
Asymmetry:	5 - 20 %	
Peak overload <1ms:	600 < 1 ms	350 V < 1 ms
Time delay t1:	fixed, max. 200 ms	
Time delay t2:	adjustable 0-10 s	
Accuracy		
Set. accuracy (mechanical):	5 %	
Repeat accuracy:	< 1 %	
Temperature dependance:	< 0.1 % / °C (°F)	
Limit values tolerance:	5 %	
Output		
Number of contacts:	2x changeover / SPDT (AgNi / Silver Alloy)	
Current rating:	16 A / AC1	
Breaking capacity:	4000 VA / AC1, 384 W / DC	
Inrush current:	30 A / < 3 s	
Switching voltage:	250 V AC1 / 24 V DC	
Min. breaking capacity DC:	500 mW	
Mechanical life:	3x10 ⁷	
Electrical life (AC1):	0.7x10 ⁵	
Other information		
Operating temperature:	-20 °C to 55 °C (-4 °F to 131 °F)	
Storage temperature:	-30 °C to 70 °C (-22 °F to 158 °F)	
Electrical strength:	4 kV (supply - output)	
Operating position:	any	
Mounting:	DIN rail EN 60715	
Protection degree:	IP40 from front panel / IP20 terminals	
Overvoltage category:	III.	
Pollution degree:	2	
Max. cable size (mm ²):	solid wire max. 1x 2.5 or 2x 1.5 / with sleeve max. 1x 1.5 (AWG 12)	
Dimensions:	90 x 52 x 65 mm (3.5 x 2 x 2.6")	
Weight:	239 g (8.4 oz.)	
Standards:	EN 60255-6, EN 61010-1	

- Monitoring 3-phase mains:
 - voltage in 2 levels (undervoltage and overvoltage) in range 138 - 276 V or 280 - 480 V (3x 400 V)
 - phase asymmetry
 - phase sequence
 - phase failure.
- Function "MEMORY" - for return from the faulty into normal state press button "RESET" located on the front panel.
- HRN-43:** for circuits 3x 400 V (without neutral).
- HRN-43N:** for circuits 3x 400 / 230 V (with neutral).
- 2 output relays, selectable function of 2nd relay (independent / parallel).
- Fixed (t1) and adjustable (t2) delay to eliminate short voltage drops and peaks.
- Galvanically separated supply voltage AC 400 V, AC 230 V, AC/DC 24 V.
- Output contact: 2x changeover / SPDT 16 A / 250 V AC1.
- 3-MODULE, DIN rail mounting.

Description

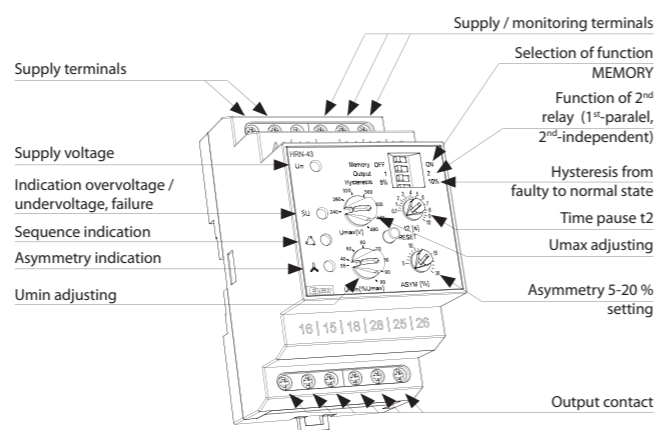

Connection

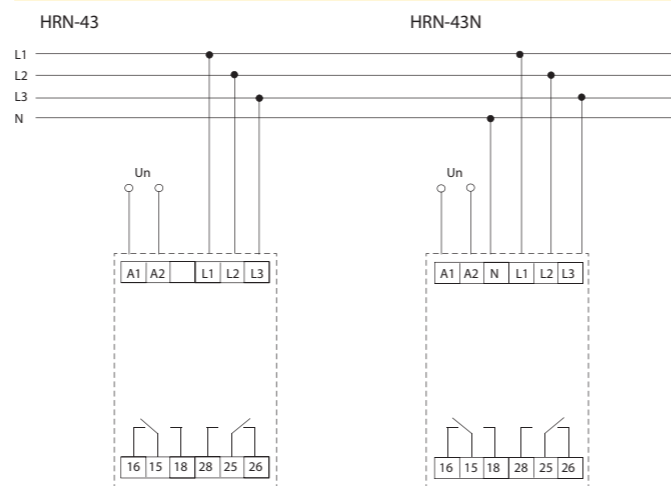

Symbol

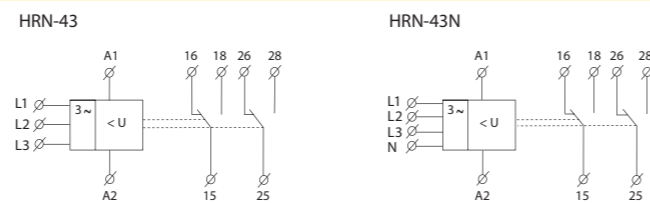

Function

Overvoltage - undervoltage

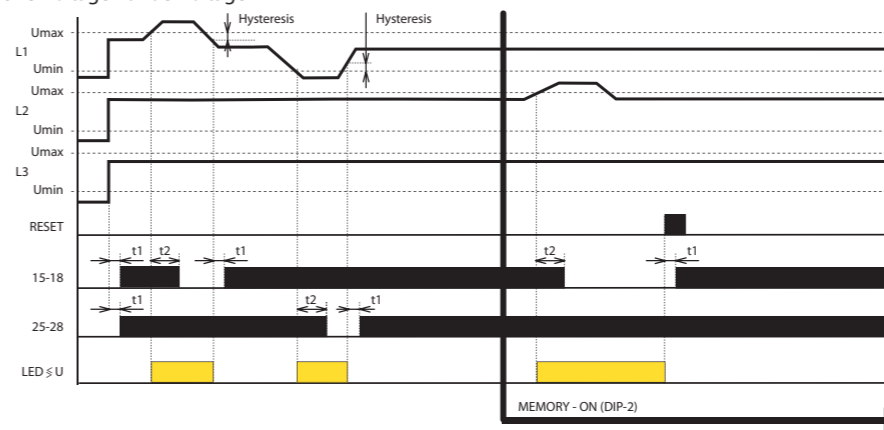

Selection of 2nd the relay function:
 In order to monitor 2 levels of voltage, it is possible to select if output relay will respond to each level individually (see the diagram) or both relays will switch in parallel way (see diagram "phase sequence"). Selection via DIP switch.

Phase sequence

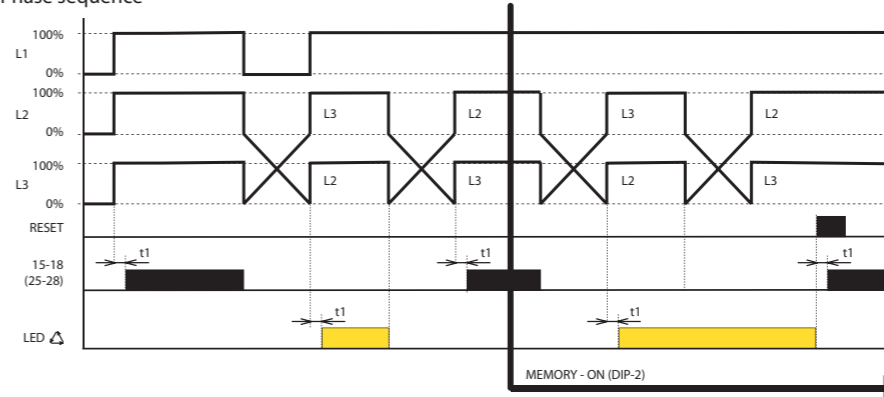

Selection of 2nd relay function:
 The function is not implied in the monitoring phase sequence, the relays are switched in parallel way. DIP switch no. 3 is ignored.

Asymmetry - phase failure

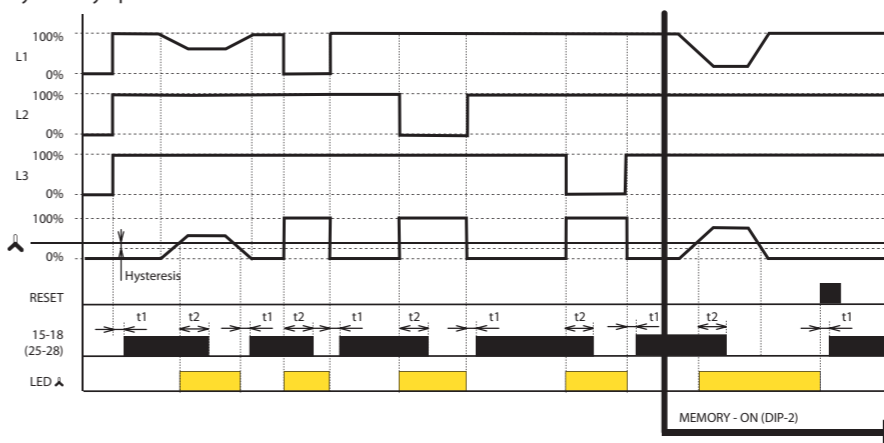

Selection of 2nd relay function:
 The function is not implied in the monitoring phase sequence, the relays are switched in parallel way. DIP switch no. 3 is ignored.

Function description

Relay is designated to monitor 3-phase circuits. Type HRN-43N controls voltage towards neutral wire, type HRN-43 controls interphase voltage. Relay can monitor voltage in two levels (overvoltage / undervoltage), phase asymmetry, sequence and failure. Each faulty state is indicated by individual LED. By DIP switch (No.3) it is possible to define function of the other relay - independent function (1x for overvoltage, 1x for undervoltage) or in parallel. Time delays t1(fixed) - when changing from faulty to normal state or when de-energized and t2 (adjustable) when changing from normal to faulty state. These delays prevent incorrect conduct and oscillation of output device during short voltage peaks in the main or during gradual voltage decline into normal.

Voltage control

Set upper level Umax in range 138 - 276 V (or 240 - 480 V for HRN-43) and lower level Umin in range 35-99 % Umax. In case any phase passes this range, after a delay which eliminated short voltage peaks, contact opens. Output contact again switches after returning back into monitored voltage range and exceeding fixed hysteresis (which is adjustable in two values by DIP switch).

Phase sequence

Monitors correctness of phase sequence. In case of unwanted change output contact breaks. In case of energization of a device with incorrect phase sequence, contact stays opened.

Asymmetry

Rate of asymmetry between individual phases is set in a range of 5-20 %. In case set asymmetry is exceeded, output relay breaks and LED indicating asymmetry shines. Delays t1, t2 and hysteric are applicable when returning to normal state.



EAN code
 HRN-56 /120V: 8595188130745
 HRN-56 /208V: 8595188130134
 HRN-56 /240V: 8595188137119
 HRN-56 /400V: 8595188137126
 HRN-56 /480V: 8595188130189
 HRN-56 /575V: 8595188130196

- Relay monitors phase sequence and failure (e.g. control of correct motor winding etc.).
- Relay is designated for monitoring of 3-phase networks.
- Supply from all phases which means that relay is functional also in case of one phase failure.
- Supply and monitored supply Un:

1-MODUL	3-MODUL
HRN-56/120 - 3x 120 V	HRN-56/480 - 3x 480 V
HRN-56/208 - 3x 208 V	HRN-56/575 - 3x 575 V
HRN-56/240 - 3x 240 V	
HRN-56/400 - 3x 400 V	
- Fixed time delay T1 (500 ms) and adjustable time delay T2 (0 -10s).
- Faulty state is indicated by LED and by opening of output relay contact.
- Output contact 1x changeover / SPDT 8 A / 250V AC1.
- 1-MODULE, 3-MODULE, DIN rail mounting.

Technical parameters	HRN-56					
	120	208	240	400	480	575
Monitoring terminals:	L1, L2, L3					
Supply terminals:	L1, L2, L3					
Supply / measured voltage:	3x 120 V / 50 Hz	3x 208 V / 50 Hz	3x 240 V / 50 Hz	3x 400 V / 50 Hz	3x 480 V / 50 Hz	3x 575 V / 50 Hz
Level Umin:	adjustable 70 - 95 % Un					
Level Uoff:	60 % Un					
Burden:	max. 2 VA					
Hysteresis:	2 %					
Max. permanent overload:	AC 3x 160 V	AC 3x 276 V	AC 3x 460 V	AC 3x 550 V	AC 3x 660 V	AC 3x 700 V
Peak overload <1s:	AC 3x 180 V	AC 3x 300 V	AC 3x 500 V	AC 3x 600 V	AC 3x 700 V	AC 3x 700 V
Time delay T1:	max. 500 ms					
Time delay T2:	adjustable 0 -10 s					
Output						
Number of contacts:	1x changeover / SPDT (AgNi / Silver Alloy)					
Current rating:	8 A / AC1					
Breaking capacity:	2500 VA / AC1, 240 W / DC			2000 VA / AC1, 240 W / DC		
Inrush current:	10 A					
Switching voltage:	250 V AC1 / 24 V DC					
Indication of state:	red LED					
Mechanical life:	1x10 ⁷			3x10 ⁷		
Electrical life (AC1):	1x10 ⁵					
Other information						
Operating temperature:	-20 °C to +55 °C (-4 °F to 131 °F)					
Storage temperature:	-30 °C to +70 °C (-22 °F to 158 °F)					
Electrical strength:	4 kV (supply - output)					
Operating position:	any					
Mounting:	DIN rail EN 60715					
Protection degree:	IP40 from front panel / IP10 terminals			IP40 from front panel / IP20 terminals		
Overvoltage category:	III.					
Pollution degree:	2					
Max. cable size (mm ²):	solid wire max. 2x 2.5 or 1x 4 / with sleeve max. 1x 2.5 or 2x 1.5 (AWG 12)			max.1x 2.5, max. 2x 1.5 / with sleeve max. 1x 1.5 (AWG 12)		
Dimensions:	90 x 17.6 x 64 mm (3.5 x 0.7 x 2.5")			90 x 52 x 65 mm (3.5 x 2 x 2.6")		
Weight:	66 g (2.3 oz)	66 g (2.3 oz)	66 g (2.3 oz)	67 g (2.3 oz)	108 g (3.8 oz)	108 g (3.8 oz)
Standards:	EN 60255-6, EN 61010-1					

Function description

Relay in 3-phase main monitors correct phase sequence and phase failure. Green LED illuminates permanently and indicates energization. In case of phase failure red LED flashes and relay turns off. When changing to faulty state, time delay applies - delay setting is done by potentiometer on the front panel of the device. In case of incorrect phase sequence, red LED shines permanently and relay is open. In case supply voltage falls below 60% Un (Uoff lower level) relay immediately opens with no delay and faulty state is indicate by red LED.

HRN-56: Thanks to supply from all phases, relay is functional also in case of one phase failure.

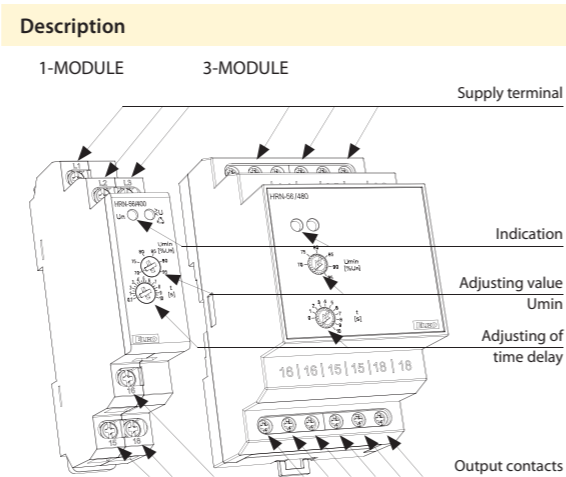

Function

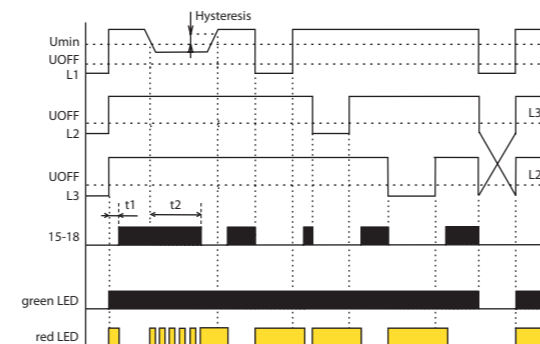

Connection

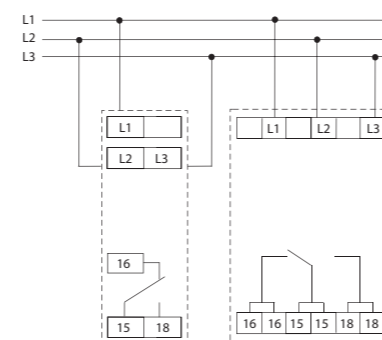

Symbol

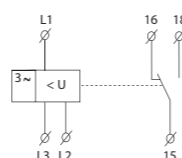

EAN code
 MPS-1: 8595188145978

Technical parameters	MPS-1
Supply voltage:	AC 3x 400/230 V / 50 - 60 Hz
Supply voltage tolerance:	+20 %, -75 %
Power consumption:	max. 1.0 VA / 0.5 W
Indication	
LED not illuminated:	0.. 50 V / 45.. 0 V
LED illuminated	
- yellow:	50.. 207 V / 195.5.. 45 V
- green:	207.. 264.5 V / 253.. 195.5 V
- red:	264.5.. 276 V / 276.. 253 V
Other information	
Design:	1 MODULE
Mounting:	DIN rail EN60715
Operating position:	any
Coverage:	panel IP40, terminals IP10
Overvoltage category:	III.
Contamination level:	2
Working temperature:	-20 °C to 55 °C (-4 °F to 131 °F)
Storage temperature:	-30 °C to 70 °C (-22 °F to 158 °F)
Dimensions:	90 x 17.6 x 64 mm (3.5 x 0.7 x 2.5")
Weight:	58 g (2 oz.)
Standards:	EN60947-1, EN60947-5-1

- Used for optical signaling of the voltage level in three phases.
- Each phase features LED signaling broken is divided by color into voltage levels:
 - voltage in tolerance of $\pm 15\%$ - green
 - overvoltage - red
 - undervoltage - yellow
 - voltage < 50 V - LED not illuminated.
- Four-wire connection - L1, L2, L3, N.
- Monitors phase voltages against neutral wire.
- Not dependent upon order of phases.
- Four-wire connection - L1, L2, L3, N.
- In 1-MODULE design, DIN rail mounting.

Description of device

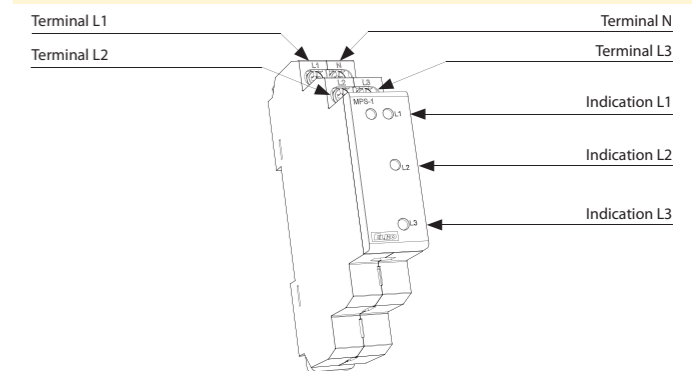

Description of function

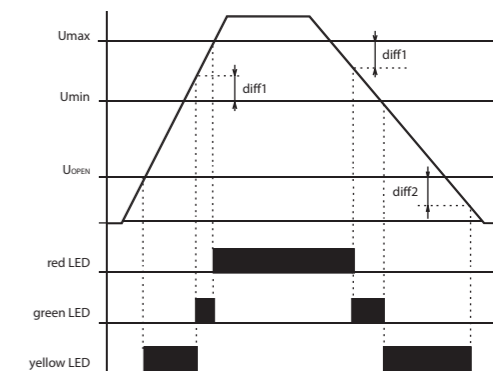

After connecting the supply voltage, the LED illuminates - the color corresponds to the voltage size of individual phases. If the phase voltage drops under 40 V (phase outage), the corresponding LED is not illuminated.

Connection

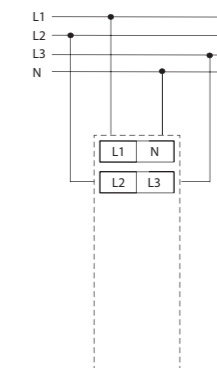



EAN code
HRF-10: 8595188144827

Technical parameters	HRF-10
Supply and monitoring terminals:	L, N
Supply voltage:	161 - 346 V
Rated frequency Fn:	50 / 60 / 400 Hz
Burden (max):	1.7 VA / 1.1 W
Overload capacity	
- continuous:	346 V
- max. 10 s:	416 V
Frequency Fmax:	adjustable 80 - 120 % Fn
Frequency Fmin:	adjustable 80 - 120 % Fn
Difference:	adjustable 0.5 - 5 % Fn
Delay (until failure):	adjustable 0.5 - 10 s
Opening level (Uopen):	161 V
Output relay - contact:	2x changeover / SPDT (AgNi) gilded
AC contact capacity:	250 V / 8 A, max. 2000 VA
DC contact capacity:	30 V / 8 A
Mechanical life:	3x10 ⁶ at rated load

Other information	
Operational temperature:	-20 °C to 55 °C (-4 °F to 131 °F)
Storing temperature:	-30 °C to 70 °C (-22 °F to 158 °F)
Electrical strength (supply - relay contact):	4 kV / 1 min.
Protection degree:	III.
Overvoltage category:	2
Pollution degree:	IP40 from front panel / IP20 terminals
Profile of connecting wires (mm ²):	max. 2x 1.5 / 1x 2.5 (AWG 12)
Dimensions:	90 x 52 x 64 mm (3.5 x 2 x 2.6")
Weight:	125 g (4.4 oz.)
Standards:	EN 60255-6, EN 60255-27, EN 61000-6-2, EN 61000-6-4

Connection

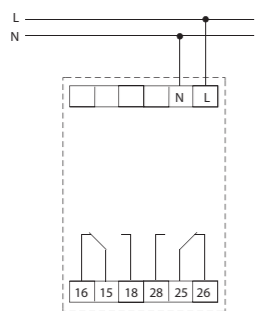

Rated frequency setting

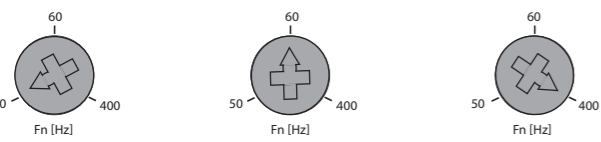

Fn setting = 50 Hz

Fn setting = 60 Hz

Fn setting = 400 Hz

- The relay serves to monitor frequency of AC voltage, e.g. in photovoltaic power stations, generators.
- The monitored frequency 50 / 60 / 400 Hz is selected by a switch.
- Supplied from monitored voltage.
- Two adjustable levels of frequency (Fmin, Fmax) in the range of 80 - 120 % Fn.
- Adjustable difference level.
- Adjustable delay level.
- Switchable ranges of rated frequency Fn.
- 3-MODULE design, DIN rail mounting.

Device description

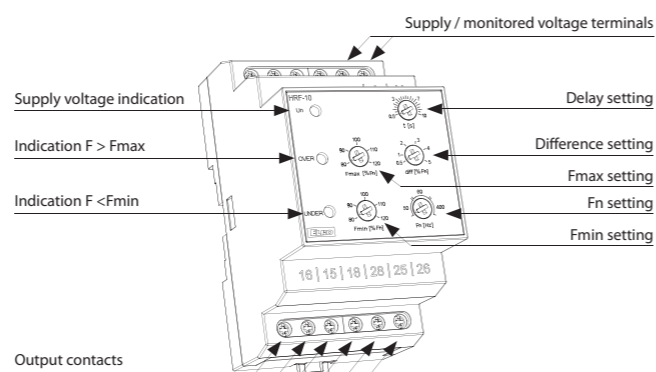

Functions

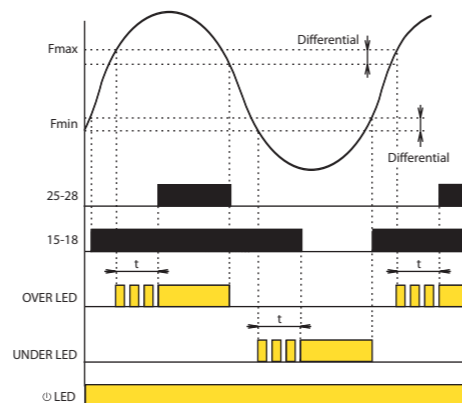

After the supply (monitored) voltage is connected, the green LED is on. If the value of the monitored frequency falls within the range between the two set levels Fmin - Fmax no red LED is on. The relay UNDER is triggered (contacts 15-16-18) and the relay OVER is disconnected (contacts 25-26-28). If the monitored frequency exceeds the set level Fmax, the relay OVER is triggered after the set delay timing elapses and the red LED OVER goes on. The red LED flashes during the timing. If the monitored frequency drops below Fmax - difference, the relay is activated without delay and the red LED OVER goes off. If the monitored frequency drops below the set level Fmin, the relay UNDER is disconnected after the set delay timing elapses and the red LED UNDER goes on. The red LED flashes during the timing. If the monitored frequency exceeds the level Fmin + the difference, the relay is triggered without delay and the red LED UNDER goes off. If the monitored voltage is lower than the opening level Uopen both the relays are disconnected and both the red LED (UNDER and OVER) start flashing slowly - indicating insufficient supply voltage.



EAN code
COS-1 /230V: 8595188120906
COS-1 /110V: 8595188120265
COS-1 /400V: 8595188120272
COS-1 /24V: 8594030338131

Technical parameters	COS-1
Supply	
Supply terminals:	A1 - A2
Voltage range:	AC 230 V, AC 110 V, AC 400 V or AC/DC 24 V (AC / 50 - 60 Hz)
Burden:	max. 4.5 VA
Operating range:	-15 %; +10 %
Measuring	
Voltage set:	3x 400 V / 50 Hz
Terminals:	L1, L2, L3, B1
Upper level cos-φ:	adjustable 0.1 - 0.99
Bottom level cos-φ:	adjustable 0.1 - 0.99
Max. permanent voltage:	(input L1, L2, L3) AC 3x 460 V
Current range:	0.1 - 16 A
Current overloading:	20 A (< 3 sec.)
Hysteresis:	adjustable 5 % or 10 %
Time delay t1:	adjustable 0.5 - 30 s
Time delay t2:	adjustable 0 - 10 s
Accuracy	
Accuracy setting (mechanical):	5 %
Accuracy of repetition:	< 1 %
Temperature dependance:	< 0.1 % / °C (°F)
Limit values tolerance:	5 %
Output	
Number of contacts:	2x changeover/ SPDT (AgNi / Silver Alloy)
Current rating:	16 A / AC1
Breaking capacity:	4000 VA / AC1, 384 W / DC
Inrush current:	20 A / < 3 s
Switching voltage:	250 V AC1 / 24 V DC
Min. breaking capacity DC:	500 mW
Output indication:	yellow LED
Mechanical life:	3x10 ⁷
Electrical life (AC1):	0.7x10 ⁵
Other information	
Operating temperature:	-20 °C to 55 °C (-4 °F to 131 °F)
Storage temperature:	-30 °C to 70 °C (-22 °F to 158 °F)
Electrical strength:	4 kV (supply - output)
Operating position:	any
Mounting:	DIN rail EN 60715
Protection degree:	IP40 from front panel / IP20 terminals
Overvoltage category:	III.
Pollution degree:	2
Max. cable size (mm ²):	max. 1x 2.5, max. 2x 1.5 / with sleeve max. 1x 1.5 (AWG 12)
Dimensions:	90 x 52 x 65 mm (3.5 x 2 x 2.6")
Weight:	240 g (8 oz.)
Standards:	EN 60255-6, EN 61010-1

- Relay monitors phase shift between current and voltage - cos-φ in 3-phase and also 1-phase main for monitoring overload / unloading of motors.
- Supply set 3x 400 V.
- Function "MEMORY" - manual reset - button on front panel.
- It is possible to connect current transformer in front of the device. This enables increase of current range.
- 2 output relays, independent for each level.
- Adjustable delay to eliminate short peak overloading.
- Adjustable range and bottom level cos-φ, of power factor between 0.1 - 0.99.
- Adjustable delay to eliminate starting of motor.
- Selectable hysteresis 5 or 10%.
- Galvanically separated supply AC 230 V, AC 400 V or AC/DC 24 V.
- Output contact: 2x changeover / SPDT 16 A / 250 V AC1.
- 3-MODULE, DIN rail mounting.

Description

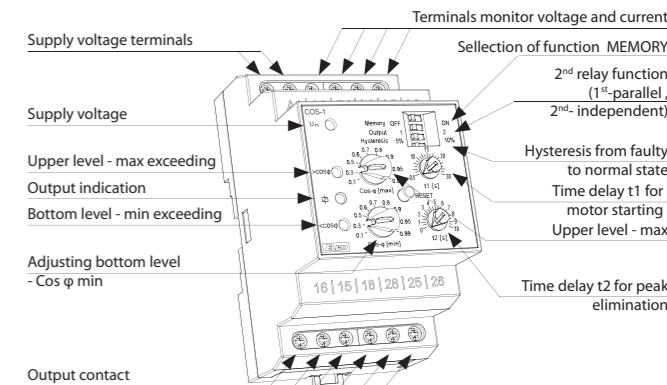

Function

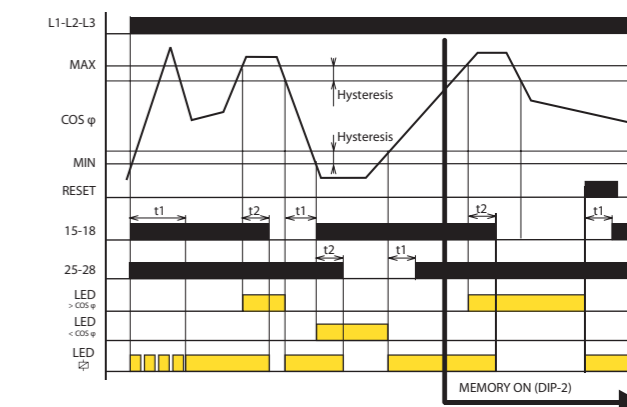

After the device is switched on, the yellow LED flashes for time t1 and both relays are switched (state OK). This delay serves to eliminate a faulty state e.g. motor start-up. If the upper limit is exceeded (cosφ - max) red LED shines > cosφ. After a time delay t2 the output relay opens (15-18). Equally, if it falls under bottom limit (cosφ - min) red LED shines < cosφ and after a time delay t2 the output relay opens (25-28). In case the load is disconnected (no current), red LED shines > cosφ (cosφ = 1).

Connection

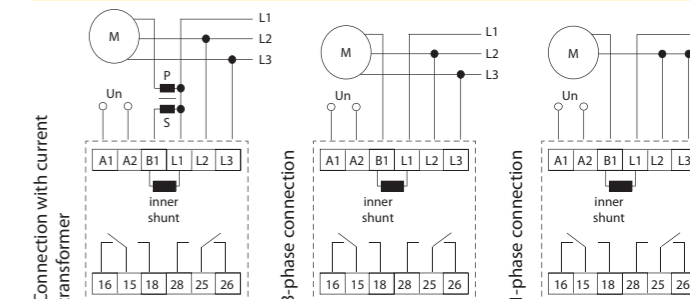

Symbol

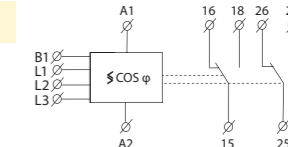



EAN code
PRI-32: 8595188121965

Technical parameters		PRI-32
Supply circuit		
Supply terminals:	A1 - A2	
Voltage range:	AC 24 - 240 V, DC 24 V (AC 50 - 60 Hz)	
Burden:	max. 1.5 VA	
Operating range:	-15 %; +10 %	
Measuring circuit		
Current range:	1 - 20 A (AC 50 Hz)	
Current adjustment:	potentiometer	
Accuracy		
Setting accuracy (mech.):	5 %	
Repeat accuracy:	< 1 %	
Temperature dependency:	< 0.1 % / °C (°F)	
Limit values tolerance:	5 %	
Overload capacity:	max. 100 A / 10 s	
Output		
Number of contacts:	1x changeover / SPDT (AgNi / Silver Alloy)	
Current rating:	8 A / AC1	
Breaking capacity:	2500 VA / AC1, 240 W / DC	
Output indication:	red LED	
Other information		
Operating temperature:	-20 °C to 55 °C (-4 °F to 131 °F)	
Storage temperature:	-30 °C to 70 °C (-22 °F to 158 °F)	
Electrical strength:	4 kV (supply - output)	
Operating position:	any	
Mounting:	DIN rail EN 60715	
Protection degree:	IP40 from front panel / IP10 terminals	
Overvoltage category:	III.	
Pollution degree:	2	
Max. cable size (mm ²):	solid wire max. 2x 2.5 or 1x 4, with sleeve max. 1x 2.5 or 2x 1.5 (AWG 12)	
Dimensions:	90 x 17.6 x 64 mm (3.5" x 0.7" x 2.5")	
Weight:	68 g (2.4 oz.)	
Standards:	EN 60255-6, EN 61010-1	

- Current transformer is a part of the product. Inside this transformer there is a wire which senses the volume of flowing current
- This construction reduces thermal stress of product when compared with conventional solutions with inbuilt shunt, and increases current range up to 20 Amps, and galvanically separates monitored circuit
- For heating bars in sliding rails, heating cables, indication of current flow, controlling of 1-phase motor consumption...
- Universal supply AC 24 - 240 V and DC 24 V
- Supply is galvanically separated from measuring current
- Current exceeding - current flowing through monitored wire must not exceed 100 A
- Output contact: 1x changeover / SPDT 8 A
- Clamp terminals
- 1-phase, 1-MODULE, DIN rail mounting

Description

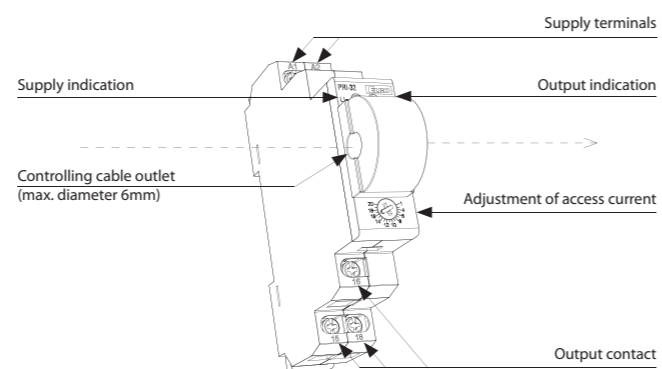

Function

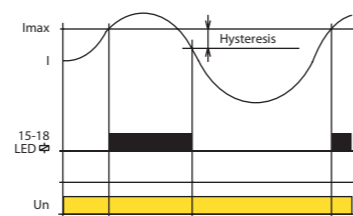

Monitoring relay PRI-32 serves to monitor current level in single phase AC circuits. Due to its fluent adjustment of release current, it is predestined for applications with necessity of current flow indication, and can be used as precedence relay. Output relay is off in normal state. In case the set current level is exceeded, it switches. Multivoltage supply is an advantage.

Connection

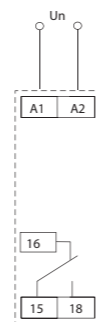

Symbol

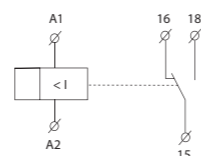

EAN code
PRI-51 /0.5A: 8595188142885
PRI-51 /1A: 8595188124904
PRI-51 /2A: 8595188124911
PRI-51 /5A: 8595188124928
PRI-51 /8A: 8595188124935
PRI-51 /16A: 8595188124942

Technical parameters		PRI-51																		
Supply circuit																				
Supply terminals:	A1 - A2																			
Voltage range:	AC 24 - 240 V and DC 24 V (AC 50 - 60 Hz)																			
Burden:	max. 1.5 VA																			
Supply voltage tolerance:	-15 %; +10 %																			
Measuring circuit																				
Load:	between B1 - B2																			
Current range:	<table border="1"> <tr> <td>PRI-51/0.5</td> <td>PRI-51/1</td> <td>PRI-51/2</td> <td>PRI-51/5</td> <td>PRI-51/8</td> <td>PRI-51/16</td> </tr> <tr> <td>AC0.05-0.5A</td> <td>AC0.1-1A</td> <td>AC0.2-2A</td> <td>AC0.5-5A</td> <td>AC0.8-8A</td> <td>AC1.6-16A</td> </tr> <tr> <td>(AC50Hz)</td> <td>(AC50Hz)</td> <td>(AC50Hz)</td> <td>(AC50Hz)</td> <td>(AC50Hz)</td> <td>(AC50Hz)</td> </tr> </table>		PRI-51/0.5	PRI-51/1	PRI-51/2	PRI-51/5	PRI-51/8	PRI-51/16	AC0.05-0.5A	AC0.1-1A	AC0.2-2A	AC0.5-5A	AC0.8-8A	AC1.6-16A	(AC50Hz)	(AC50Hz)	(AC50Hz)	(AC50Hz)	(AC50Hz)	(AC50Hz)
PRI-51/0.5	PRI-51/1	PRI-51/2	PRI-51/5	PRI-51/8	PRI-51/16															
AC0.05-0.5A	AC0.1-1A	AC0.2-2A	AC0.5-5A	AC0.8-8A	AC1.6-16A															
(AC50Hz)	(AC50Hz)	(AC50Hz)	(AC50Hz)	(AC50Hz)	(AC50Hz)															
	↑ applicable also for current transformer																			
Max. permanent current:	0.5 A 1 A 2 A 5 A 8 A 16 A																			
Inrush overload <1ms:	100 A																			
Current adjustment:	potentiometer																			
Time delay:	adjustable 0.5 - 10 s																			
Accuracy																				
Setting accuracy (mechanical):	5 %																			
Repeat accuracy:	< 1 %																			
Temperature dependency:	< 0.1 % / °C (°F)																			
Limit values tolerance:	5 % (10 % for 0.05 - 0.5 A range)																			
Hysteresis (fault to OK):	5 %																			
Output																				
Number of contacts:	1x changeover / SPDT (AgNi / Silver Alloy)																			
Current rating:	8 A / AC1																			
Breaking capacity:	2500 VA / AC1, 240 W / DC																			
Output indication:	green / red LED																			
Other information																				
Operating temperature:	-20 °C to 55 °C (-4 °F to 131 °F)																			
Storage temperature:	-30 °C to 70 °C (-22 °F to 158 °F)																			
Electrical strength:	4 kV (supply - output)																			
Operating position:	any																			
Mounting:	DIN rail EN 60715																			
Protection degree:	IP40 from front panel / IP10 terminals																			
Overvoltage category:	III.																			
Pollution degree:	2																			
Max. cable size (mm ²):	solid wire max. 2x 2.5 or 1x 4, with sleeve max. 1x 2.5 or 2x 1.5 (AWG 12)																			
Dimensions:	90 x 17.6 x 64 mm (3.5" x 0.7" x 2.5")																			
Weight:	72 g (2.54 oz.)																			
Standards:	EN 60255-6, EN 61010-1																			

Symbol

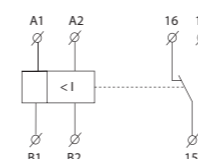

Example of an order

Always specify all reference name of current relay according to required range, for example PRI-51/5.

- It serves for monitoring of heating in rail-switches, heating cables, consumption of one-phase motors, indicates current flow
- Flexible adjustment by potentiometer, choice of 6 ranges: AC 0.05 - 0.5A; AC 0.1 - 1A; AC 0.2 - 2A; AC 0.5 - 5A; AC 0.8 - 8A; AC 1.6 - 16A
- Adjustable delay 0.5 - 10 s to eliminate short current peaks
- It is possible to use for current scanning from current transformer - up to 600 A!
- Universal supply AC 24 - 240 V and DC 24 V
- Supply is galvanically separated from measured current, it must be in the same phase
- Output contact: 1x changeover / SPDT 8 A
- 1-phase, 1-MODULE, DIN rail mounting

Description

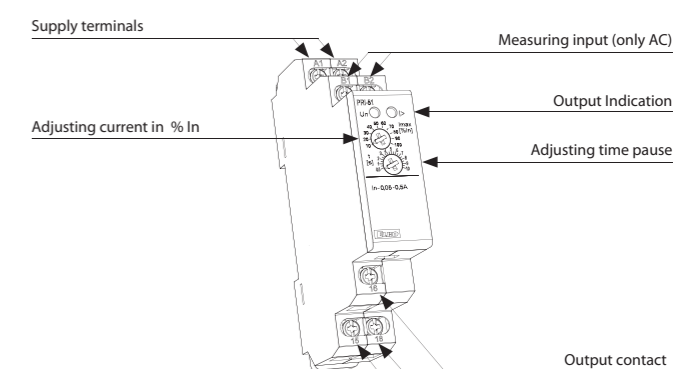

Function

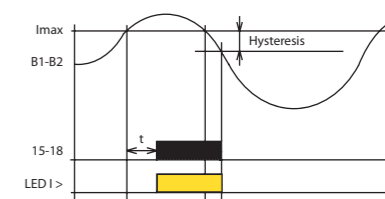

Monitoring relay PRI-51 serves to monitor current level in one-phase AC circuits. Gradual setting of actuating current of monitoring relay enables many different applications. Output relay is in normal state opened. After the set current level is reached, relay closes after the set delay (0.5 - 10s). When returning from faulty to normal state there is a hysteresis (5 %). Multi-voltage of this relay is an advantage. It is possible to monitor load which doesn't have the same supply as monitoring relay PRI-51. Range of PRI-51 can be increased by an external current transformer.

Connection

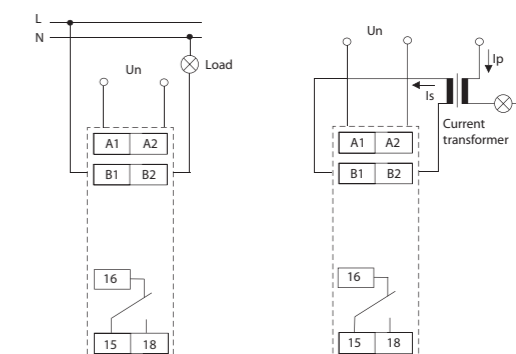

Example Connection:
PRI-51 with current transformer for current range increase.



EAN code
PRI-52: 8595188136556

Technical parameters PRI-52

Supply	
Supply terminals:	A1 - A2
Voltage range:	AC 230 V / 50 - 60 Hz
Tolerance of voltage range:	-15 %; +10 %
Burden (apparent):	max. 5 VA
Burden (loss):	max. 1.4 W
Measuring circuit:	
Current range:	AC 0.5 ... 25 A / 50 Hz
Maximal permanent current:	25 A
Inrush overload <1s:	100 A
Current adjustment:	potentiometer
Time delay:	adjustable 0.5 ... 10 s
Accuracy	
Setting accuracy (mech.):	10 %
Repeat accuracy:	< 1 %
Temperature dependence:	< 0.2 % / °C
Limit values tolerance:	10 %
Hysteresis:	0.25 A
Output	
Number of contacts:	1x changeover / SPDT (AgNi / Silver Alloy)
Current rating:	8 A / AC1
Switching power:	2500 VA / AC1, 240 W / DC
Output indication:	red LED
Other information	
Operating temperature:	-20 °C to 55 °C (-4 °F to 131 °F)
Storing temperature:	-30°C to 70 °C (-22 °F to 158°F)
Electrical strength:	4 kV (supply - output)
Operating position:	any
Mounting:	DIN rail EN 60715
Protection degree:	IP40 from front panel / IP10 terminals
Overtoltage category:	III.
Pollution level:	2
Max. cable size (mm ²):	max. 2x 2.5, max. 1x 4 / with sleeve max. 1x 2.5, max. 2x 1.5 (AWG 12)
Dimensions:	90 x 17.6 x 64 mm (3.5" x 0.7" x 2.5")
Weight:	64 g (2.26 oz.)
Standards:	EN 60255-6, EN 61010-1

Connection

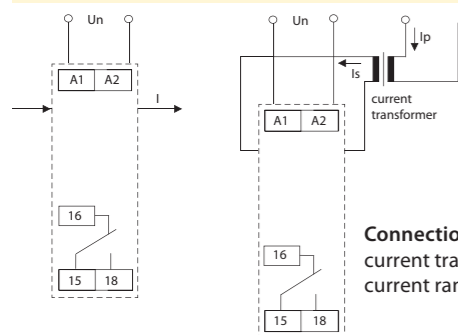

Connection example: PRI-52 with current transformer for increasing of current range.

- Relay is designated for:
 - distant device diagnostic (short circuit, take-off increasing)
 - preferred (priority) relay - two appliances (boiler and floor heating) operating on one phase, but never run together - prevention against current overload and circuit breaker tripping. Enables to save your main breaker expenses.
 - current tranzit indicator - informs about heating activation, ceramic hob, ventilator...
 - changing over of appliances according to inverter's (converter) output by photocell applications.
- NEW - hole for threaded conductor passes through the body of device.
- Part of device is current transformer, which monitors size of current in threaded conductor.
- Possible to use also for sensing of current up to 600 A from external current transformer.
- Slight setting (by potentiometer) of tripping current - range AC 0.5 - 25 A.
- Slight setting (by potentiometer) of delay - adjustable in range 0.5 - 10s.
- Supply voltage AC 230 V.
- Output contact 1x changeover / SPDT 8 A (AC1).
- 1-phase version, 1-MODULE, DIN rail mounting, clamp terminals.

Description

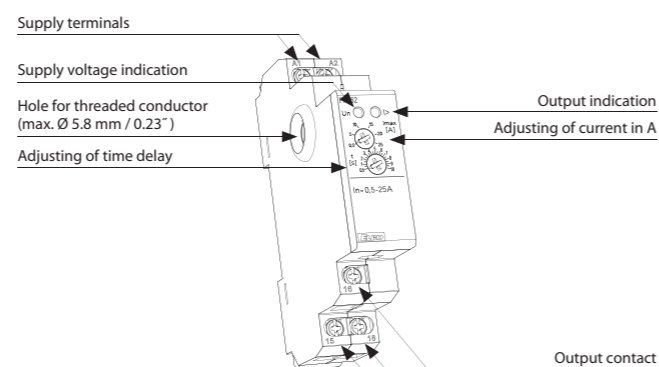

Functions

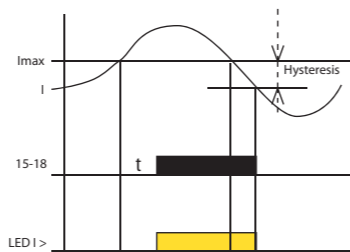

Monitoring relay PRI-52 serves for monitoring of current level in 1-phase AC circuits. Slight setting of release current level designates this relay for many various applications. Output relay is in normal status switched off. When set current level is overrun, relay get closed after preset delay. By return from error to normal status is used hysteresis.

PRI-52 range is possible to increase with external current transformer.

Advantage of PRI-52 is that the hole for threaded conductor is located under the level of covering in the switchboard - thanks that, threaded conductor is not accessible for unwanted manipulation.

Symbol

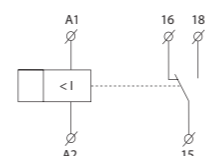

EAN code
PRI-53/1: 8595188142137
PRI-53/5: 8595188142144

Technical parameters PRI-53/1 PRI-53/5

Supply terminals:	A1, A2	
Current monitoring terminals		
1st phase:	I1, I2	
2nd phase:	I3, I4	
3rd phase:	I5, I6	
Supply voltage:	24 - 240 V AC/DC	
Tolerance of voltage range:	± 10 %	
Operating AC frequency:	45 - 65 Hz	
Burden: (max):	3 VA / 1.2 W	
Rated current In:	AC 1 A	AC 5 A
Current level - I:	adjustable 40 - 120 % In	
Overload capacity		
- continuous:	2 A	10 A
- max. 3s:	20 A	50 A
Difference:	fix 1 % In	
Delay (until failure):	adjustable 0.5 - 10s	
Output relay - contact:	2x changeover / SPDT (AgNi) gilded	
AC contact capacity:	250 V / 8 A, max. 2000 VA	
DC contact capacity:	30 V / 8 A	
Mechanical life:	3x10 ⁶ at rated load	
Other information		
Operating temperature:	-20 °C to 55 °C (-4 °F to 131 °F)	
Storing temperature:	-30°C to 70 °C (-22 °F to 158°F)	
Electrical strength		
(power supply - relay contact):	4 kV / 1 min.	
Overtoltage category:	III.	
Pollution level:	2	
Protection degree:	IP40 from front panel / IP20 terminal	
Max. cable size (mm ²):	max. 2x 1.5 / 1x 2.5 (AWG 12)	
Dimensions:	90 x 105 x 64 mm (3.5 x 4.1 x 2.5")	
Weight:	208 g (7.3 oz.)	
Standards:	EN 60255-6, EN 60255-27, EN 61000-6-2, EN 61000-6-4	

Connection

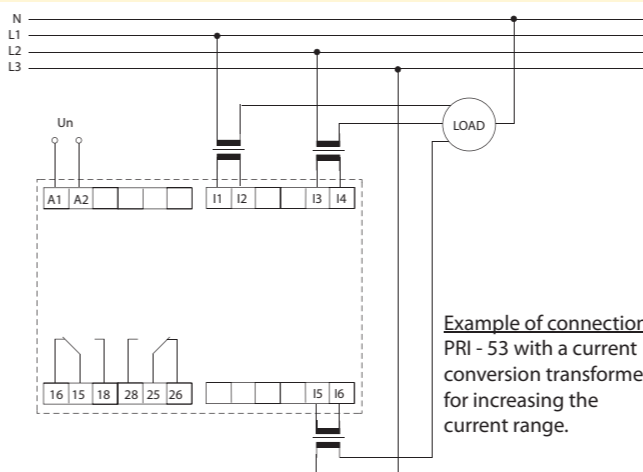

Example of connection: PRI - 53 with a current conversion transformer for increasing the current range.

- It is intended for monitoring the current in three-phase devices (e.g. cranes, motors, etc.).
- 24 - 240 V AC/DC power supply galvanically separated from the circuit of the monitored current.
- Adjustable current level in % of In.
- Fixed difference level.
- Adjustable delay level (when exceeding the preset limit).
- Adjustable function:
 - UNDER - monitors the drop in the strength of current below the preset value (I).
 - OVER - exceeding the preset value (I).
- 2 types depending on the strength of rated current In (1 A, 5 A).
- 6-MODULE, DIN rail mounting.
- Output relay with 2 changeover contacts.
- Option of connecting via the current transformers to increase the value of the monitored current by up to 600 A.

Description

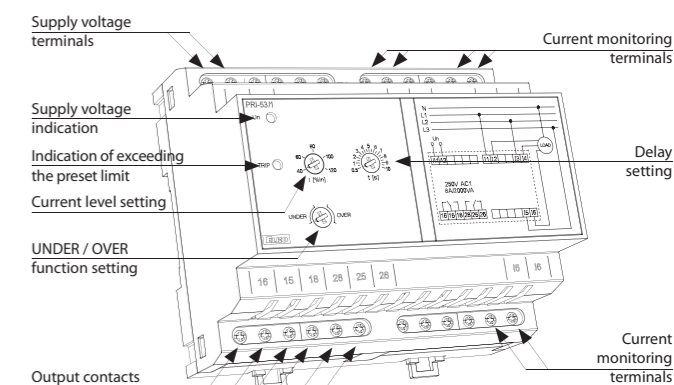

Functions

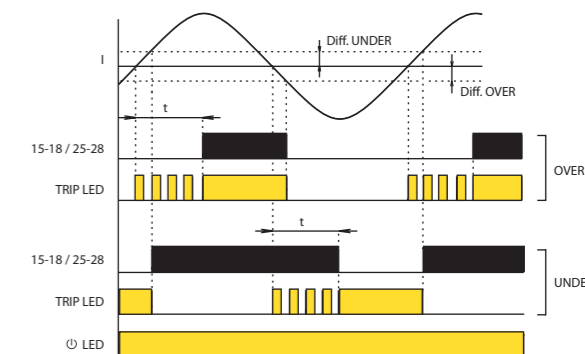

After the supply voltage is connected the green LED is on.

UNDER function:

If the strength of the monitored current in all phases exceeds the preset level I, the relay is triggered and the red LED is off. If the strength of the monitored current drops in any phase below the level I, the relay is disconnected after the preset delay timing elapses and the red LED goes on. The red LED flashes during the delay.

If the strength of the monitored current returns above the level I + difference, the relay is triggered without delay and the red LED goes off.

OVER function:

If the strength of the monitored current is lower in all phases than the preset level I, the relay is disconnected and the red LED is off.

If the strength of the monitored current exceeds in any phase the level I, the relay is triggered after the preset delay timing elapses and the red LED goes on. The red LED flashes during the delay.

If the strength of the monitored current again drops below the level I - difference, the relay is disconnected without delay and the red LED goes off.



EAN code
 PRI-41/230V: 8595188140485
 PRI-41/24V: 8595188140492
 PRI-42/230V: 8595188140515
 PRI-42/24V: 8595188140522

Technical parameters	PRI-41	PRI-42	
Supply circuit			
Supply terminals:	A1 - A2		
Voltage range:	AC 230 V or AC / DC 24 V (AC 50 - 60 Hz)		
Burden max.:	2.5 W / 5 VA (AC 230 V), 1.4 W / 2 VA (AC/DC 24 V)		
Operating range:	-15 %; +10 %		
Measuring circuit			
Ranges*:	AC/DC 3.2 - 16 A (AC 50 - 60 Hz)	AC/DC 1 - 5 A (AC 50 - 60 Hz)	AC/DC 0.32 - 1.6 A (AC 50 - 60 Hz)
Terminals:	C - B1	C - B2	C - B3
Input resistance:	2.3 mΩ	11 mΩ	23 mΩ
Max. permanent current:	16 A	7.3 A	1.6 A
Inrush overload <1ms:	20 A	6.3 A	2 A
Time delay for Imax:	adjustable 0-10 s		
Time delay for Imin:	adjustable 0-10 s		
Accuracy			
Measuring accuracy:	5 %		
Repeat accuracy:	< 1 %		
Temperature dependency:	< 0.1 % / °C		
Limit values tolerance:	5 %		
Hysteresis (fault to OK):	selectable 5 % / 10 % from range		
Output			
Number of contacts:	2x changeover / SPDT (AgNi / Silver Alloy)		
Current rating:	16 A / AC1		
Breaking capacity:	4000 VA / AC1, 384 W / DC		
Inrush current:	30 A / < 3 s		
Switching voltage:	250 V AC1 / 24 V DC		
Min. breaking capacity DC:	500 mW		
Output indication:	yellow LED		
Mechanical life:	3x10 ⁷		
Electrical life (AC1):	0.7x10 ⁶		
Other information			
Operating temperature:	-20 °C to 55 °C (-4 °F to 131 °F)		
Storage temperature:	-30 °C to 70 °C (-22 °F to 158 °F)		
Electrical strength:	4 kV (supply - output)		
Operating position:	any		
Mounting:	DIN rail EN 60715		
Protection degree:	IP40 from front panel / IP20 terminals		
Overvoltage category:	III.		
Pollution degree:	2		
Max. cable size (mm ²):	solid wire max. 1x 2.5 or 2x 1.5 / with sleeve max. 1x 1.5 (AWG 12)		
Dimensions:	90 x 52 x 65 mm (3.5" x 2" x 2.6")		
Weight:	24V - 142 g (5 oz), 230V - 243 g (8.6 oz)		
Standards:	EN 60255-6, EN 61010-1		

Symbol

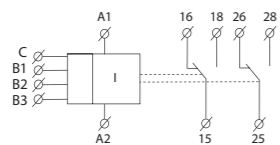

- Used to monitor overloading / relief (machine, motor, etc.), check consumption, diagnostics on a remote device (burning, short circuit, increased current draw, etc.).
- Relay designed for monitoring DC and AC currents in three ranges.
- The relay controls the current size in two independent levels (Imax, Imin).
- Setting the monitored level Imax (in % of range).
- Setting the monitored level Imin (in % of range - for PRI-42 -function WINDOW), (in % of the set upper limit - for PRI-41 - function HYSTERESIS).
- Adjustable function "MEMORY".
- Function of second relay (independently / in parallel).
- Adjustable delay for eliminating short-term outages and surges for every level independently.
- Galvanically separated power supply from monitoring inputs.
- Output contact: 2x changeover 16 A / 250 V AC1 for each current level.
- 3-MODULE, DIN rail mounting.
- * Only one of the inputs can be connected.

Description

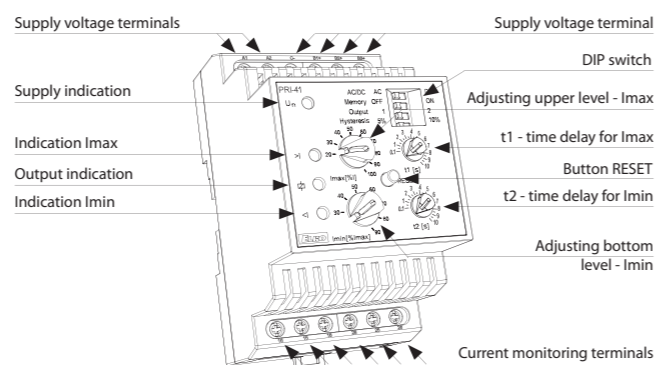

Function

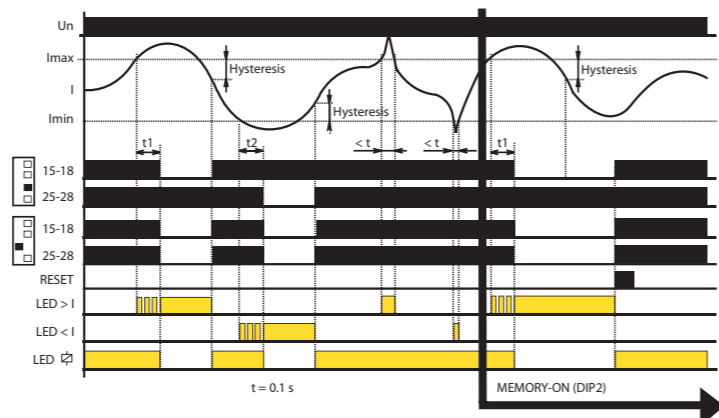

Connection

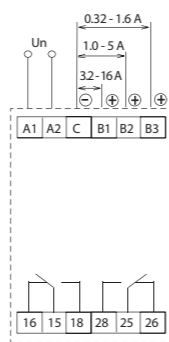

- if the value of the monitored current is in the zone between the set upper and lower levels, the status OK occurs - both relays are closed and the yellow LED illuminates. If the value of the monitored current is outside the set limits (> Imax or < Imin), an error state occurs.
- when moving to an error state I > Imax, it times the delay t1 and a red LED > I simultaneously flashes. After the t1 time elapses, the red LED > I illuminates and the relevant relay opens.
- when moving to an error state I < Imin, it times the delay t2 and a red LED < I simultaneously flashes. After the time t2 elapses, the red LED < I illuminates and the relevant relay opens.
- when moving from the error status to the OK status, the relevant red LED immediately goes out, and the corresponding relay closes.



EAN code
 HRH-5: 8595188136396

Technical parameters	HRH-5
Functions:	2
Supply terminals:	A1 - A2
Voltage range:	24.. 240 V AC/ DC (AC 50 - 60 Hz)
Input:	max. 2 VA
Tolerance of voltage range:	-15 %; +10 %
Measuring circuit	
Sensitivity (input resistance):	adjustable in range 5 kΩ - 100 kΩ
Voltage n electrodes:	max. AC 3.5 V
Current in probes:	AC < 0.1 mA
Time response:	max. 400 ms
Max. capacity of probe cable:	800 nF (sensitivity 5kΩ), 100 nF (sensitivity 100 kΩ)
Time delay (t):	adjustable, 0.5 - 10 sec
Time delay after switching on (t1):	1.5 sec
Accuracy	
Accuracy in setting (mech.):	± 5 %
Output	
Number of contacts:	1x changeover / SPDT (AgNi / Silver Alloy)
Current rating:	8 A / AC1
Switching voltage:	2500 VA, 240 W
Switched voltage:	250 V AC1 / 24 V DC
Min. switched output DC:	500 mW
Mechanical life (AC1):	1x10 ⁷
Electrical life:	1x10 ⁶
Other information	
Operational temperature:	-20 °C to 55 °C (-4 °F to 131 °F)
Storing temperature:	-30 °C to 70 °C (-22 °F to 158 °F)
Electrical strength:	3.75 kV (supply - sensors)
Operational position:	any
Mounting:	DIN rail EN 60715
Protection degree:	IP40 from front panel / IP10 terminals
Overvoltage category:	II.
Pollution degree:	2
Profile of connecting wires (mm ²):	max. 2x 2.5, max. 1x 4 / with sleeve max. 1x 2.5, max. 2x 1.5 (AWG 12)
Dimensions:	90 x 17.6 x 64 mm (3.5" x 0.7" x 2.5")
Weight:	72 g (2.5 oz.)
Standards:	EN 60255-6, EN 61010-1
Recommended measuring probes:	see pg. 95

Symbol

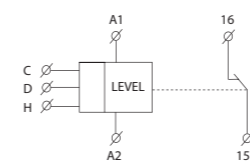

- Relay is designed for monitoring levels in wells, basins, reservoirs, tanks...
- In one device you can choose the following configurations:
 - one-level switch of conductive liquids (by connecting H and D)
 - two-level switch of conductive liquids.
- One-state device monitors one level, two-state device monitors two levels (switches on one level and switches off on another level).
- Choice of function PUMP UP, PUMP DOWN.
- Adjustable time delay on the output (0.5 - 10s).
- Sensitivity adjustable by a potentiometer (5 - 100 kΩ).
- Measuring frequency 10 Hz prevents polarization of liquid and raising oxidation of measuring probes.
- Galvanically separated supply voltage UNI 24.. 240 V AC/DC.
- Output contact 1xchangeover/SPDT 8A/250V AC1.
- 1-MODULE, mounting onto DIN rail.

Device description

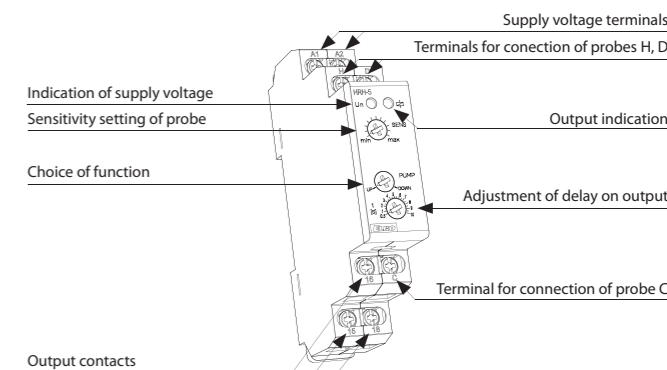

Function

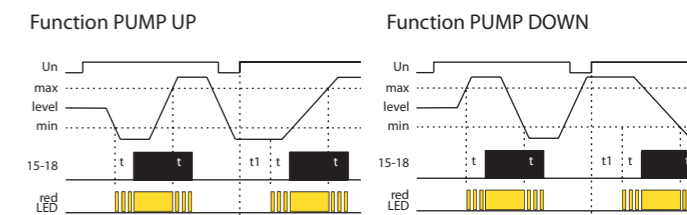

Relay is designated for monitoring of levels of conductive liquids with possibility of functions: PUMP UP or PUMP DOWN. To prevent polarization and liquid electrolysis of liquid, and undesirable oxidation of measuring probes, alternating current is used. For measuring use three measuring probes: H- upper level, D- lower level, C - common probe. In case you use a tank made of a conductive material, you can use it as probe C. In case you require monitoring of one level only, it is necessary to connect inputs H and D and connect them to one probe - in this case sensitivity is lowered by half (2.5.. 50 kΩ). Probe C can be connected with a protective wire of supply system (PE). To prevent undesirable switching out output contacts by various influences (sediment on probes, humidity...) it is possible to set sensitivity of the device according to conductivity of monitored liquid (corresponding to "resistance" of liquid) range 5 up to 100 kΩ. To reduce influences of undesirable switching of output contacts by liquid gorgle in tanks, it is possible to set delay of output reaction 0.5 - 10s.

Connection

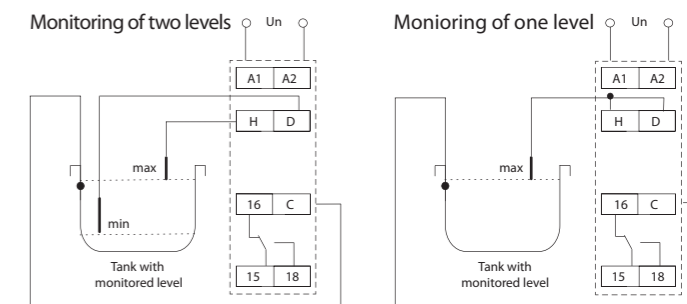



EAN code
HRH-1 / 230V: 8594030337783
HRH-1 / 24V: 8594030338209

Technical parameters		HRH-1
Function:		3
Supply terminals:		A1 - A2
Voltage range:		AC 110 V, AC 230 V, AC 400 V or AC/DC 24V galvanically separated (AC 50-60Hz)
Burden:		max. 4.5 VA
Supply voltage tolerance:		-15 %; +10 %
Measuring circuit		
Hysteresis (input - opening):		in an adjustable range 5 kΩ - 100 kΩ
Voltage on electrode:		max. AC 5 V
Current in probes:		AC < 1 mA
Time reaction:		max. 400 ms
Max. cable capacity:		4 nF
Time delay tD:		adjustable 0.5 - 10 sec
Time delay tH:		adjustable 0.5 - 10 sec
Accuracy		
Setting accuracy (mech.):		± 5 %
Output		
Number of contacts:		2x changeover / SPDT (AgNi / Silver Alloy)
Current rating:		16 A / AC1
Breaking capacity:		4000 VA / AC1, 384 W / DC
Inrush current:		30 A / < 3 s
Switching voltage:		250 V AC1 / 24 V DC
Min. breaking capacity DC:		500 mW
Mechanical life:		3x10 ⁷
Electrical life (AC1):		0.7x10 ⁹
Other information		
Operating temperature:		-20 °C to 55 °C (-4 °F to 131 °F)
Storage temperature:		-30 °C to 70 °C (-22 °F to 158 °F)
Electrical strength:		4 kV (supply - output)
Operating position:		any
Mounting:		DIN rail EN 60715
Protection degree:		IP40 from front panel / IP20 terminals
Overvoltage category:		III.
Pollution degree:		2
Max. cable size (mm ²):		solid wire max. 1x 2.5 or 2x1.5 / with cavern max. 1x 1.5 (AWG 12)
Dimensions:		90 x 52 x 65 mm (3.5" x 2" x 2.6")
Weight:		240 g (8 oz.)
Standards:		EN 60255-6, EN 61010-1
Measuring sensors:		see pg. 95

- Used to control the level in wells, reservoirs, tanks, pools, tankers, containers, etc.
- Within the framework of a single device, the following configurations can be selected (see functions graph):
 - two separate level switches
 - two probes in one tank
 - filling tank from well.
- Single-state monitors one level (full or empty tank), double-state monitors two levels (switches on upon one level and switches off upon the second).
- DIP switch on front panel is used to choose function (see functions graph):
 - pumping in
 - pumping out
 - over-pumping.
- Option of setting time delay for reacting to the output upon a change in level, any type of delay by DIP switch.
- Sensitivity adjustable by potentiometer (probe resistance based on fluid).
- The measuring frequency 500 Hz prevents fluid polarization and oxidation increase of measured probes.
- Galvanically separated supply AC 230 V or AC/DC 24 V.
- Output contact 2x switches 16 A / 250 V AC1.
- 3-MODULE design, mounting onto DIN rail.

Description

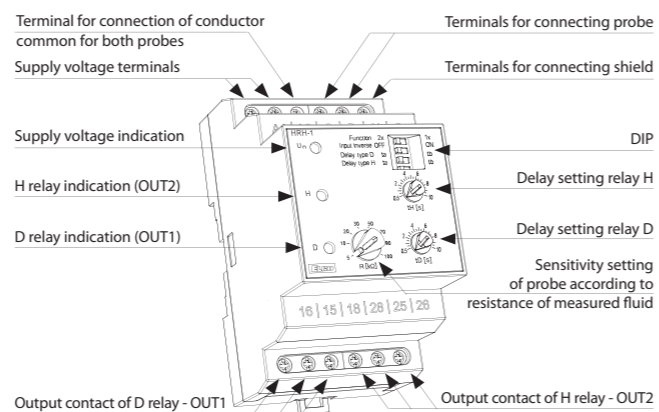

Description and importance of DIP switches



Connection

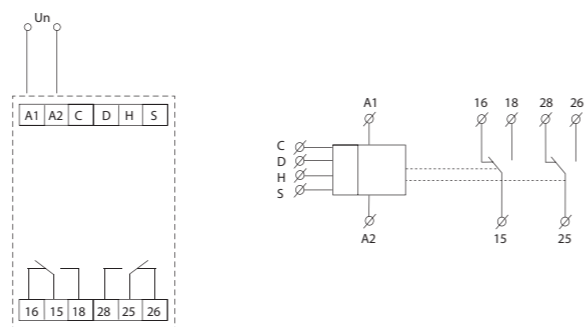

Measuring probes

There can be any measuring probe (any conductive contact, it is recommended to use brass or stainless steel). The probe wire does not need to be shielded, but it is recommended. When using a shielded wire, the shielding is connected to terminal S.

Functions

Two separate level switches

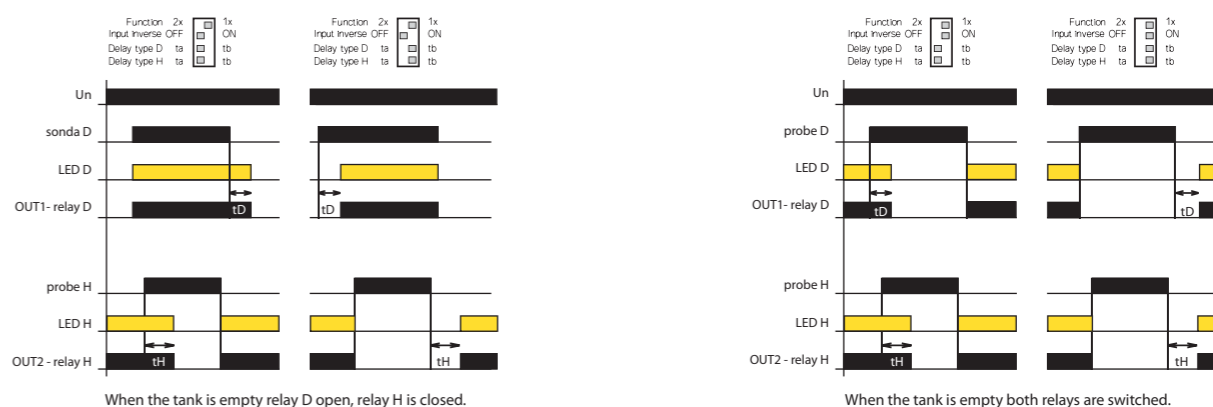

Two probes in single tank

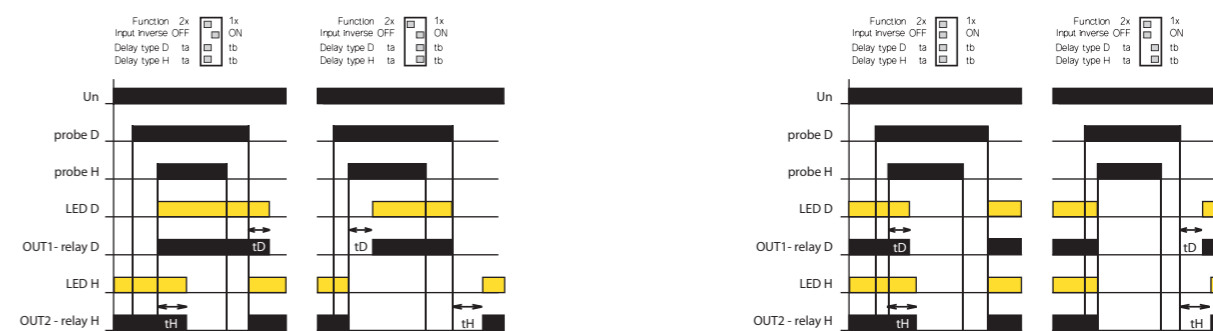

Example of usage

For controlling two independent tanks

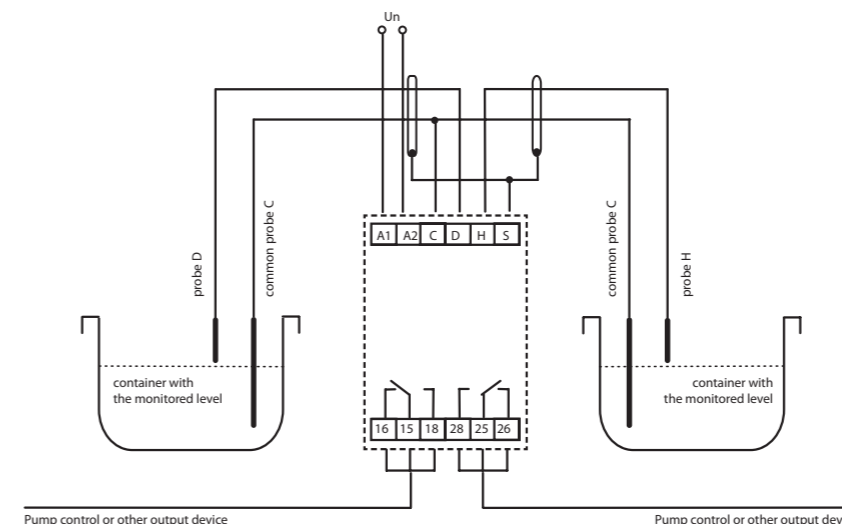

For controlling the level combination of upper and bottom probe

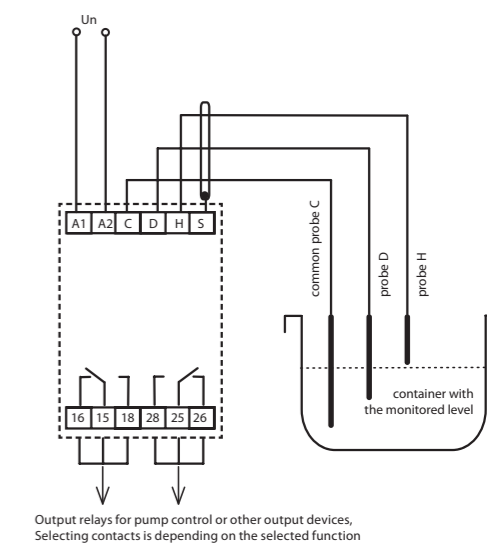

Note:
As a common probe, it could be used with an advantage such as metal pipes, tanks, etc. Due to the isolation of probes from a supply voltage, and the measured voltage which is up to 5 V, it is possible to connect probes using standard communication cables.



EAN code
HRH-6 /AC: 8595188136990
HRH-6 /DC: 8595188137409
HRH-6S: 8595188137416

Technical parameters	HRH-6/DC	HRH-6/AC
Function:		2
Voltage range:	12.. 24 V DC	230 V AC / 50 - 60 Hz
Burden:	max. 1.8 W	max. 3.8 VA
Supply tolerance:	± 20%	-20 %; +10 %
Measuring circuit		
Sensitivity adjustable in the range*:		min. 10 kΩ max. 200 kΩ
Voltage on probes:		max. 3 V AC
Probe cable maximum capacity:		500 nF (for min. sensitivity), 50 nF (for maximum sensitivity)
Time delay:		adjustable 1.. 10 s
Output		
Number of contacts:		6x LED (1x red, 1x yellow, 4x green)
Current rating:		10 A / AC1
Switching voltage:		2500 VA / AC1, 200 W / DC
Peak current:		16 A / < 3 s
Switching voltage:		250 V AC1 / 24 V DC
Min. switching capacity DC:		500 mW
Mechanical life (AC1):		3x10 ⁷
Electrical life:		0.7x10 ⁵

Other information		
Operating temperature:	-20 °C to 55 °C (-4 °F to 131 °F)	
Storage temperature:	-30 °C to 70 °C (-22 °F to 158 °F)	
El. strength (supply - probes):	x	3.75 kV
Operating position:	any	
Protection degree:	IP65	
Overvoltage category:	x	III.
Pollution degree:	2	
Dimensions:	110 x 135 x 72 mm (4.3" x 5.3" x 2.8")	
Weight:	384 g (13.55 oz.)	284 g (10.01 oz.)
Standards:	EN 60255-6, EN 61010-1	
Recommended measuring probe:	see pg. 95	

* Note: sensitivity is higher at both ends of a range of values.

Connection

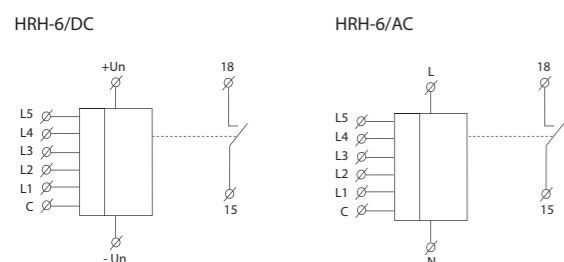

- Function 1 monitors minimal and maximal level depth, for example in fire engine cars, tanks etc.
- Function 2 monitors level depth in water collectors, basins, pools etc.
- Selection of particular function is made by jumper on the front panel.
- Level depth is indicated on the panel of device by LED.
- Device monitors 5 levels by using six probes (one probe is common).
- Common probe can be replaced by a metal (conductive) tank.
- Level indication by six LED's on the front panel of the device.
- It is possible to connect another indication module (e.g. in fire-engine cabin).
- Adjustable sensitivity according to liquid conductivity.
- Adjustable time delay - elimination of level movement, e.g. while a tank is being filled up.
- Measuring frequency 10 Hz to prevent polarization of liquid.
- Supply voltage 12.. 24 V DC (to be used in fire-engines) or galvanically separated 230 V AC for general use.
- Contact relay 10 A for signalization of full / empty tank (according to a chosen function).
- Choice of functions PUMP UP / OFF / PUMP DOWN by a switch located on the front panel of the device.
- Protection degree IP65.

Description of function

HRH-6/DC Basic unit

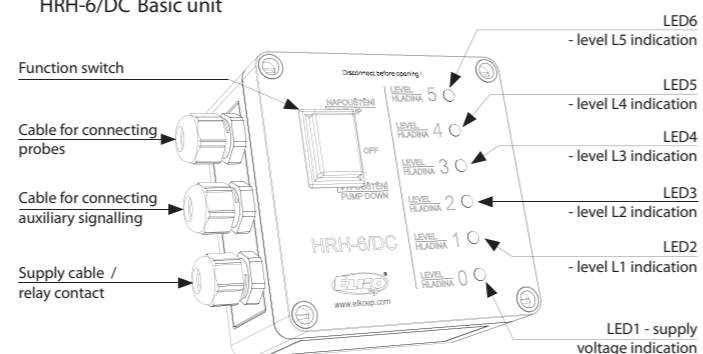

HRH-6/S Auxiliary signalling

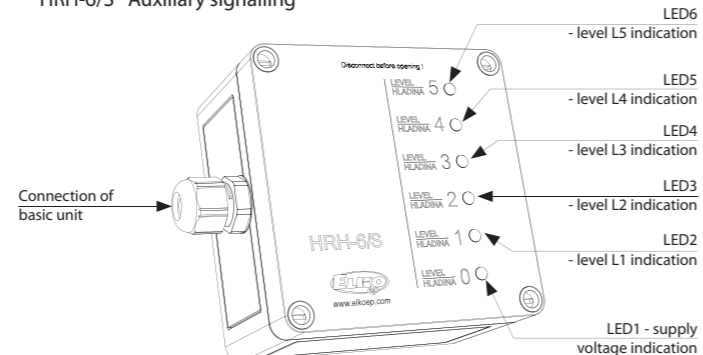

Connection of HRH-6 in a block

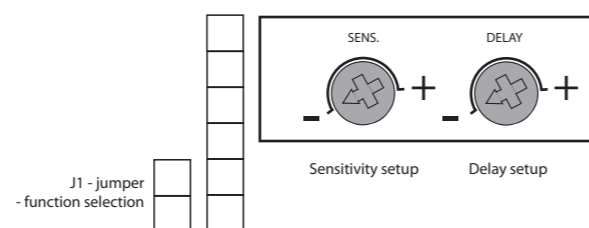

HRH-6 block connecting

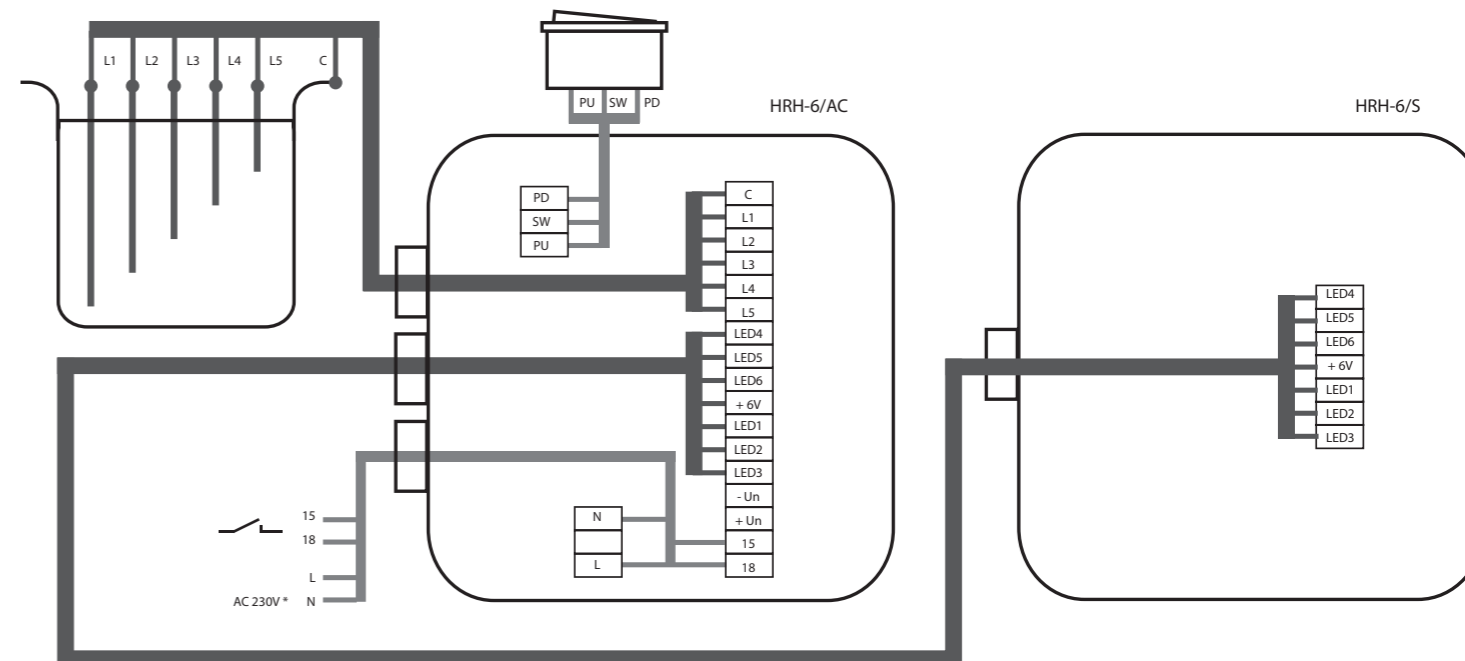

* In case of HRH-6/DC, incoming supply is connected on terminals +Un and - Un.

Functions

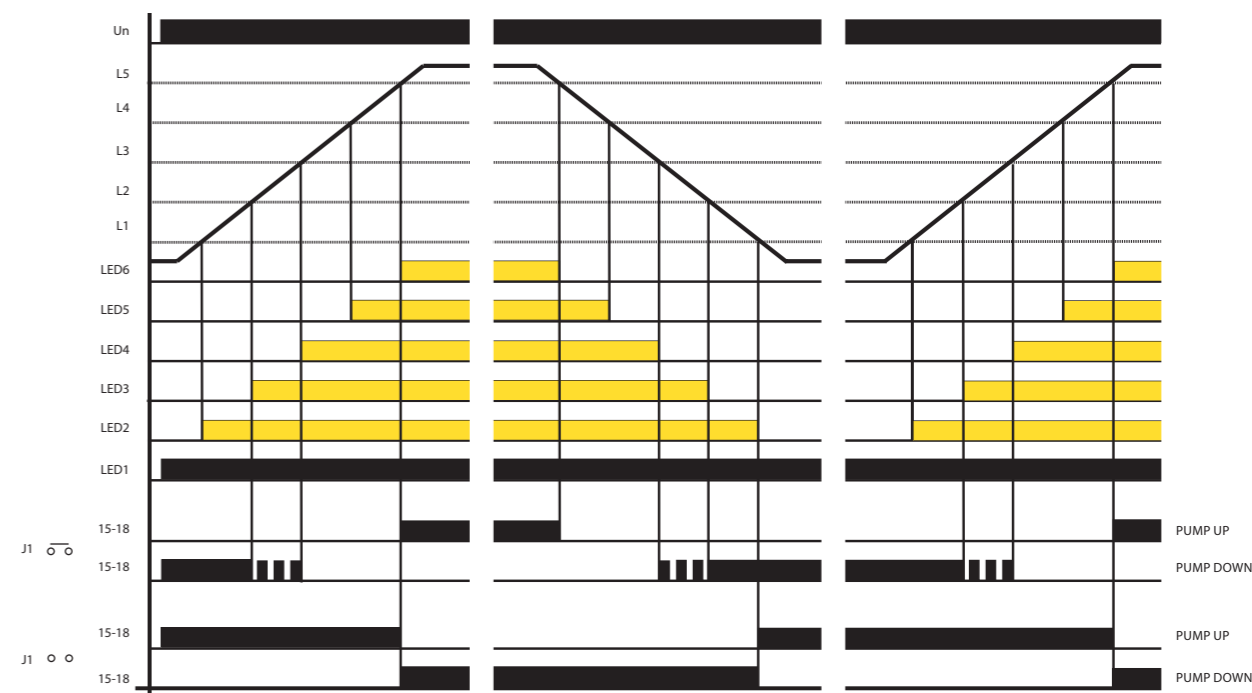

This device monitors level of a conductive liquid in a tank by using six single probes or one 6-fold probe. In case you use a tank made of a conductive material, it is possible to use it as a common probe C.

This common probe is connected to a pole of supply (for fire-engines it means its body) in case of supply voltage 12.. 24 V DC.

In case of supply voltage 230 V AC, the circuits are galvanically separated from the main.

The device is controlled by a three-position switch PUMP UP / OFF / PUMP DOWN. After switching into a position PUMP UP or PUMP DOWN, red LED1 shines and then also LED2.. LED6 according to liquid level. Output relay has 2 selectable functions.

Function setting is done by a jumper on basic board of HRH-6.

Function 1: (for use in fire-engines) - jumper is applied. In case of function PUMP UP and level reaching L5, the relay controlling e.g. acoustic signalization, permanently closes and indicated full tank. In case of PUMP DOWN function and level drop under level L3, relay periodically switches and under L2 it switches permanently (indicates almost empty tank).

Function 2: (for keeping liquid level) - jumper is not applied. In case of PUMP UP, sensor is switched until liquid reaches level L5. Then relay opens and switches again in case the liquid level falls under level L1. In case of PUMP DOWN - relay is switched until liquid falls under level L1. Then relay opens and switches again on level L5.

To eliminate LED flashing while level gurgles it is possible to delay reaction of probes (set delay 1.. 10s). According to conductivity of liquid it is possible to set sensitivity of probes (corresponding to "resistance" of liquid).



EAN code
HRH-7: 8595188149471

Technical parameters		HRH-7
Function:		2
Supply terminals:		A1 - A2
Supply voltage:		24.. 240 V AC/ DC (AC 50 - 60 Hz)
Burden:		max. 2 VA
Supply voltage tolerance:		-15 %; +10 %
Max. value of overcharge protection:		16 A
Measuring circuit		
Sensitivity (input resistance):		adjustable from 5 kΩ - 100 kΩ
Voltage on electrodes:		max. AC 3.5 V
Current on probes:		AC < 0.1 mA
Time response:		max. 400 ms
Max. capacity of probe cable:		800 nF (sensitivity 5kΩ), 100 nF (sensitivity 100 kΩ)
Time delay (t):		adjustable, 0.5 - 10 sec
Time delay (t1):		1.5 sec
Accuracy		
Setting accuracy (mechanical):		± 5 %
Output		
Number of contacts:		1x switching / DPDT (AgSnO ₂)
Current rating:		16 A / AC1
- contact NO:		15-18: 6A / AC3
- contact NC:		15-16: 3A / AC3
Switching capacity:		4000 VA / AC1, 384 W / DC
Switching voltage:		250 V AC / 24 V DC
Minimum switching capacity DC:		500 mW
Mechanical life:		3x10 ⁷
Electrical life (AC1):		0.7x10 ⁵
Other information		
Operating temperature:		-20 °C to 55 °C (-4 °F to 131 °F)
Storage temperature:		-30 °C to 70 °C (-22 °F to 158 °F)
Electrical strength:		3.75 kV (supply - sensor)
Operating position:		any
Protection:		IP65
Overvoltage category:		III.
Contamination degree:		2
Cable size (mm ²):		max. 1x 4, max. 2x 2.5 / with sleeve max. 1x 2.5, 2x 1.5 (AWG 12)
Dimension:		114 x 114 x 56 mm (4.5 x 4.5 x 2.2")
Weight:		234 g (8.3 oz.)
Related standards:		EN 60255-6, EN 61010-1
Recommended measuring probes:		see pg. 95

Symbol

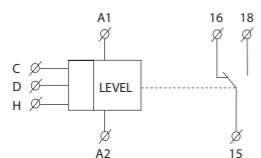

- Suitable to operate / work in harsh conditions due to the high degree of protection IP65
- Switch monitors the level changes in wells, reservoirs, tanks, tankers etc.
- It is possible to select the following configurations:
 - one-level switch of conductive liquids monitors one level (by connecting H and D)
 - two-level switch of conductive liquids monitors two levels (switches on at one level and switched off at another level)
- Choice of function PUMP-UP or PUMP-DOWN
- Adjustable time delay of output (0.5 - 10 s)
- Adjustable sensitivity using potentiometer (5 - 100 kΩ)
- Measuring frequency 10 Hz prevents liquid polarization and increased oxidation of measuring probes
- Measuring circuits are galvanically separated from the power source of the product and circuits of the relay contact by enhanced insulation according to EN 60664-1 for overvoltage category III.
- Output contact: 1x changeover / DPDT 16 A / 250 V AC1

Device description

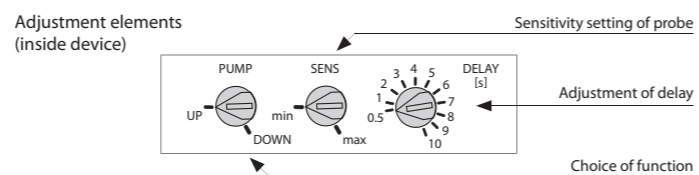
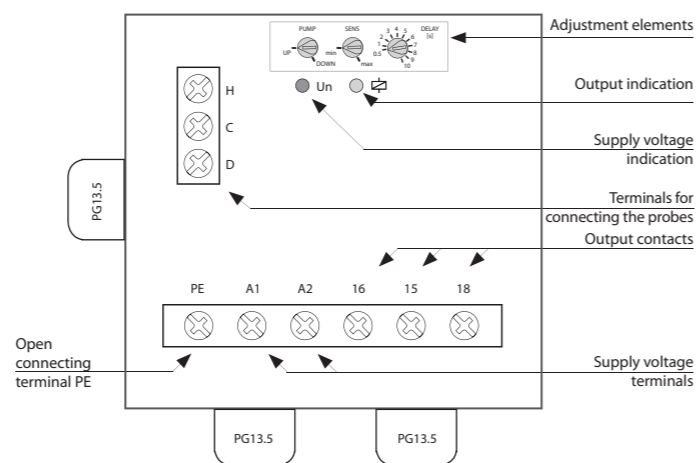

Connection

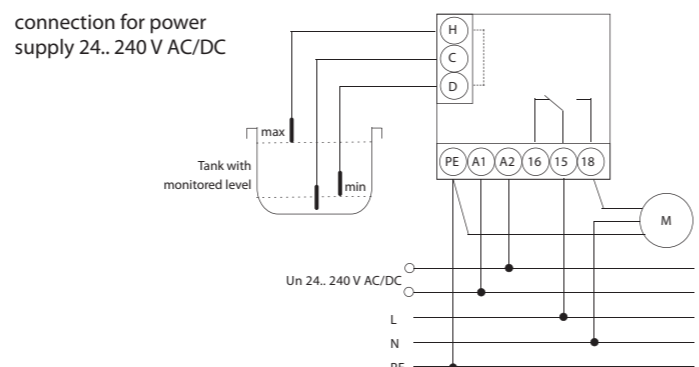
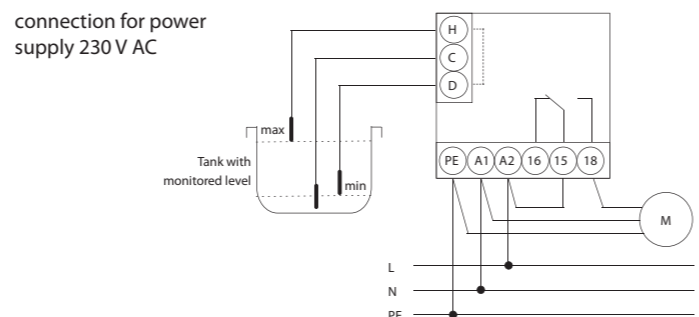

Function



An AC current is used for measuring to prevent polarization and electrolysis of fluid and unwanted oxidation of measuring probes. Three probes are used for measuring: H - upper level, D - lower level and C - common probe. If using a tank made from conductive material, it is possible to use the tank itself as probe C. If it is necessary to monitor only one level, there are two connection options:
 1. Inputs H and D are connected to a single probe - in this case the sensitivity is decreased to half (2.5.. 50 kΩ).
 2. Inputs H and C are connected and the probe is connected to input D - in this case, the original sensitivity remains (5..100 kΩ).
 It is also possible to connect probe C with a protective conductor of the power system (PE).

Example of connecting the level switch to a 1-phase pump at a well, borehole

wiring for supply 230 V AC (for monitoring two levels)

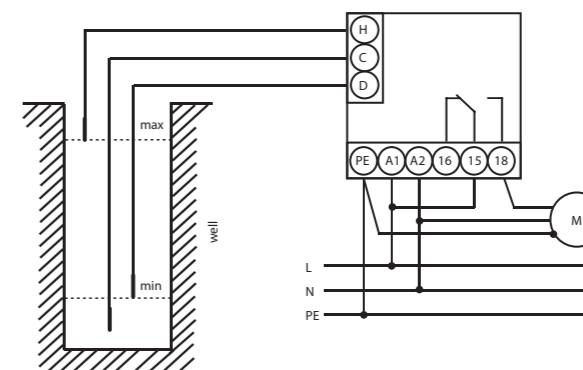

Monitoring TWO LEVELS of the FLUID LEVEL minimum / maximum - DRAINING function - (PUMP DOWN)

Description of draining function:
 This function is used in a well or borehole where the difference between the upper and lower probes determines how much water the pump can pump out and protect against running dry.
 After detecting the maximum level, the set reaction delay begins running. After this period, the output contact immediately switches on the pump until the minimum level is reached, when the set delay begins running once again. The pump then switches off.

Monitoring TWO LEVELS minimum / maximum - REPLENISHING function - (PUMP UP)

Description of replenishing function:
 This function is used when you need to regularly pump in water to a well or borehole, which is leaking.
 After detecting the minimum level, the set reaction delay begins running. After this period, the output contact immediately switches on the pump for the period until it reaches the maximum level, where the set delay begins running once again. The pump then switches off.

Example of connecting the level switch to a 3-phase pump at the well, borehole

wiring for supply 230 V AC (for monitoring two levels)

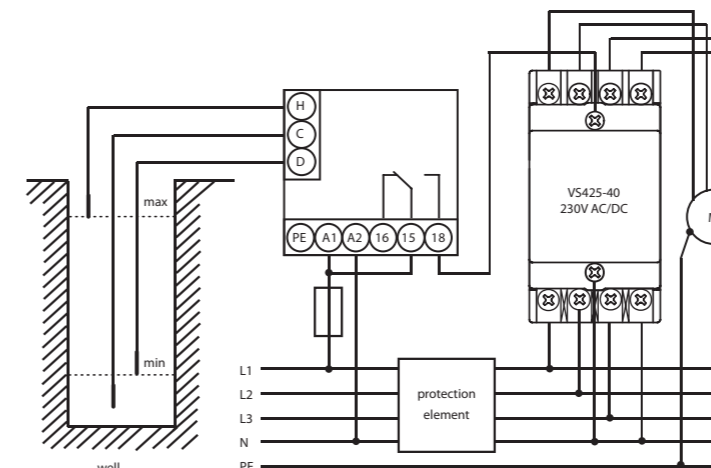

Monitoring TWO LEVELS minimum / maximum - DRAINING function - (PUMP DOWN)

Description of draining function:
 The function is used to protect against overflows and flooding of areas.
 After detecting the maximum level, the set reaction delay begins running. After this period, the output contact immediately switches on the 3-phase pump until the minimum level is reached, when the set delay begins running once again. The pump then switches off.



- Level sets are used to monitor levels in wells, reservoirs, tanks...
- Advantage is the possibility of setting PUMP UP and PUMP DOWN and also delayed switching (e.g. in case of level fluctuations).
- The possibility of connection to 1 or 3-phase pump (depending on the type of set).
- Easy to install without complicated wiring - ready for installation.
- There are Level sets placed in switchboard with IP65 protection (protected against dust and against water jets)
 - **HRH-VS:** level switch HRH-5 with installation contactor VS425-40 (25A contact)
 - **HRH-MS-1A:** level switch HRH-5 with motor starter MS18 0.63-1A
 - **HRH-MS-1.6A:** level switch HRH-5 with motor starter MS18 1-1.6A
 - **HRH-MS-VS-2.5A:** level switch HRH-5 with installation contactor VS425-40 (25A contact) and with motor starter MS18 1.6-2.5 A
 - **HRH-MS-VS-4A:** level switch HRH-5 with installation contactor VS425-40 (25A contact) and with motor starter MS18 2.5-4 A
 - **HRH-MS-VS-6.3A:** level switch HRH-5 with installation contactor VS425-40 (25A contact) and with motor starter MS18 4-6.3 A

EAN code
 HRH-VS: 8595188150699
 HRH-MS-1A: 8595188150873
 HRH-MS-1.6A: 8595188150705
 HRH-MS-VS-2.5A: 8595188150880
 HRH-MS-VS-4A: 8595188150712
 HRH-MS-VS-6.3A: 8595188150835

Technical parameters	HRH-VS	HRH-MS-1A	HRH-MS-1.6A	HRH-MS-VS-2.5A	HRH-MS-VS-4A	HRH-MS-VS-6.3A
----------------------	--------	-----------	-------------	----------------	--------------	----------------

Function:	2					
Voltage range:	230 / 400 V AC/ DC (AC 50 - 60 Hz)					
Input:	4.6 VA	2 VA	2 VA	4.6 VA	4.6 VA	4.6 VA
Tolerance of voltage range:	-15 %; +10 %					
Measuring circuit						
Sensitivity (input impedance):	adjustable in range 5 kΩ - 100 kΩ					
Voltage on the electrodes:	max. AC 3.5 V					
Current in probes:	AC < 0.1 mA					
Time response:	max. 400 ms					
Max. capacity of probe cable:	800 nF (sensitivity 5 kΩ), 100 nF (sensitivity 100 kΩ)					
Time delay (t):	adjustable, 0.5 - 10 sec					
Time delay after switching on (t1):	1.5 sec					

Accuracy:

Setting accuracy (mech.):	± 5 %					
---------------------------	-------	--	--	--	--	--

Output

Number of contacts:	4	1	1	4	4	4
Rated thermal current:	25 A	8 A	8 A	25 A	25 A	25 A
Load on AC3:	4 kW	1 A	1.6 A	2.5 A	4 A	6.3 A
Switching voltage:	230 V / 400 V	230 V	230 V	400 V AC	400 V AC	400 V AC
Electric life (A3):	0.5 x 10 ⁶	1 x 10 ⁵	0.5 x 10 ⁶	0.5 x 10 ⁶	0.5 x 10 ⁶	0.5 x 10 ⁶
Current setting range MS18:	-	0.63 - 1 A	1 - 1.6 A	1.6 - 2.5 A	2.5 - 4 A	4 - 6.3 A

Other information

Operating temperature:	-20 °C to 55 °C (-4 °F to 131 °F)					
Storage temperature:	-25 °C to 70 °C (-13 °F to 158 °F)					
Electrical strength:	3.75 kV (supply - probe)					
Operating position:	any					
Protection degree:	IP65 set					
Pollution degree:	2					
Dimension:	201 x 128 x 120 mm (7.9 x 5 x 4.7")			201 x 202 x 120 mm (7.9 x 7.9 x 4.7")		
Weight:	842 g (29.7 oz.)	872 g (30.7oz.)	872 g (30.7oz.)	1342 g (47.3 oz.)	1342 g (47.3 oz.)	1342 g (47.3 oz.)
Related standards:	EN 60255-6, EN 61010-1					
Recommended measuring probes:	see pg. 95					

Functions

PUMP DOWN function (DOWN) used for protection against Idle Running or against overflow and flooding areas.

Detecting the maximum level results in activation of adjusted delayed response. After that output contact immediately turns on single or 3-phase pump until it reaches the minimum level. Then the pump turns off.

In case that a reservoir is made of a conductive material e.g. metal tanks, there can be a difference in connection of HRH-5 level sets - it is not necessary to put inside a common probe „C“ and connect with SHR-2 probe, but thanks to conductivity of vessel we can connect probe C to the reservoir body.

The length of wire cable (between the level switch and probe) can be up to 50 m. We don't recommend placing near the power lines, because the sensitivity of equipment can be affected and thus the entire functionality.

Recommended accessories:

- 3 wire cable D03VV-F 3x0,75/3,2

- 1 wire cable D05V-K 0,75/3,2

- SHR-2 probe - probe covered by PVC (protected) - used in moderately polluted waters, drilling, wells. Assembly - hanging in the well.

Connection

Level set HRH-VS

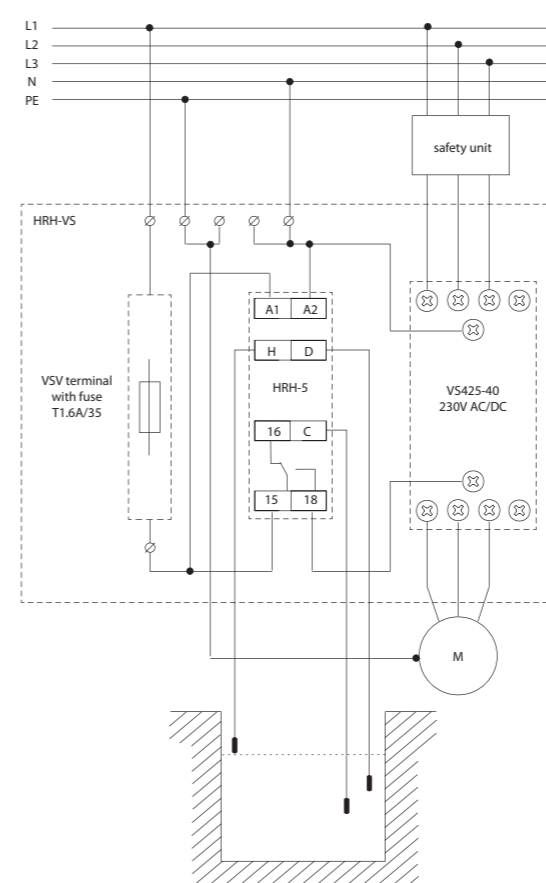

Level set HRH-MS-1A (HRH-MS-1.6A)

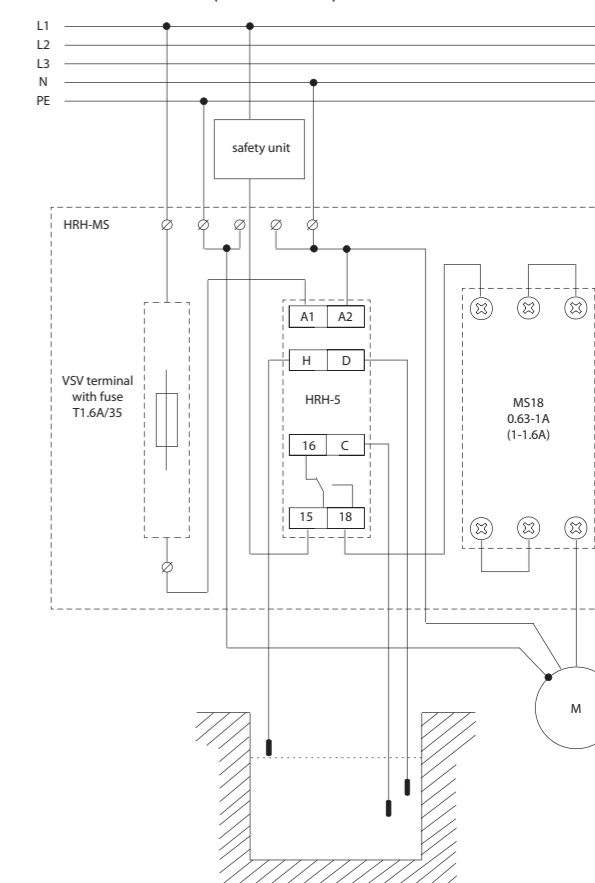

Level set HRH-MS-VS-2.5A (HRH-MS-VS-4A, HRH-MS-VS-6.3A)

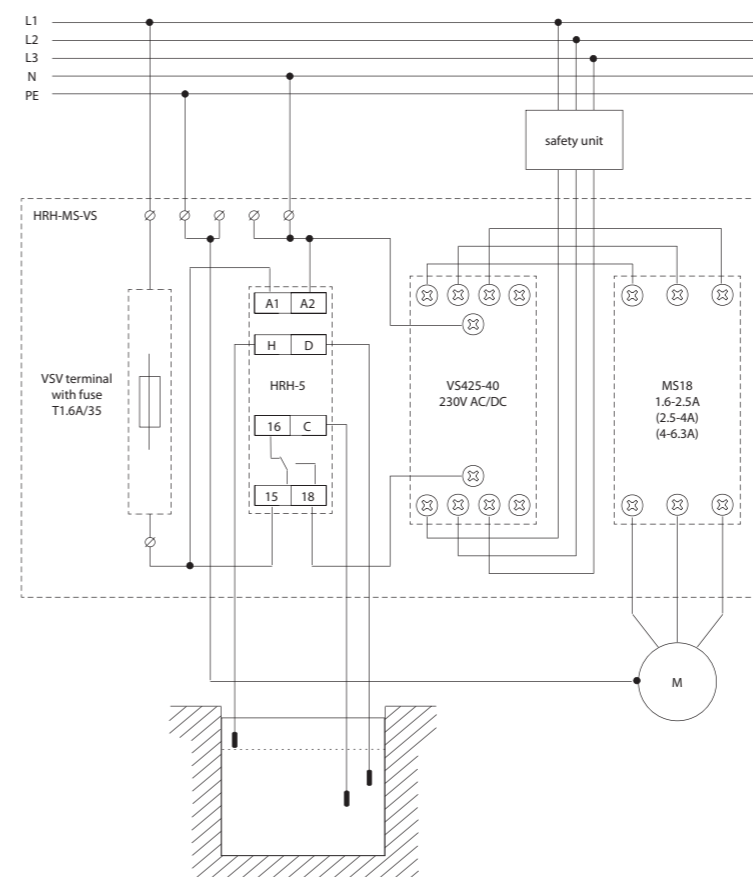



EAN code
HRH-4 /230V: 8595188117517
HRH-4 /24V: 8595188117500

Technical parameters		HRH-4
Function:		2
Voltage range:		AC/DC 230 V or AC/DC 24 V (AC 50 - 60 Hz)
Burden:		7 VA
Operating range:		-15 %; +10 %
Measuring circuit		
Sensitivity (input resistance):		adjustable in range 5 kΩ - 100 kΩ
Voltage on electrodes:		max. AC 3.5 V
Current on probes:		AC < 0.1 mA
Time response:		max. 400 ms
Max. capacity of probe cable:		800 nF (sensitivity 5 kΩ), 100 nF (sensitivity 100 kΩ)
Time delay (t):		adjustable, 0.5 - 10 sec
Time delay (t1):		1.5 sec
Accuracy		
Setting accuracy (mech.):		± 5 %
Output		
Number of contacts:		4x switching
Rated thermal current:		25 A
Loading in AC3:		4 kW / 400 V
Mechanical life:		3x10 ⁶
Other information		
Operation temperature:		-20 °C to 55 °C (-4 °F to 131 °F)
Storage temperature:		-30 °C to 70 °C (-22 °F to 158 °F)
Electrical strength (supply-output):		3.75 kV, galvanically insulated
Operating position:		any
Protection degree:		IP55
Pollution degree:		2
Dimensions:		160 x 135 x 83 mm (6.3" x 5.3" x 3.3")
Weight:		834 g (29.4 oz.)
Standards:		EN 60255-6, EN 61010-1
Recommended measuring probes:		see pg. 95

Function description

- 1) PUMP UP - in case the level falls under a lower limit (sensor D), a relay switches and a pump pumps a liquid up until it reaches an upper limit (probe H), then a relay opens and a pump stops pumping. When a level reaches a lower limit again, all process is repeated. After the device is energized, relay automatically closes and a pump pumps liquid to upper limit.
- 2) PUMP DOWN - in case a level reaches over an upper limit, a relay closes and a pump pumps liquid down. In case a level reaches a lower limit, a relay opens and a pump stops pumping. When energized, a relay is in an open state and a pump operates only after an upper limit is exceeded.
- 3) In case you combine inputs H and D and connect them to one probe, the device will keep only one level (upper and lower limit will become one). In function PUMP UP relay closes in case the level falls under a probe level. A pump pumps liquid up and in case the level reaches a probe level, a relay opens and a pump stops. The level is kept in a small range around the probe. In function PUMP DOWN relays closes in case a level reaches a probe level. A pump pumps down until the level reaches a probe, then relay opens and pump stops.

- In an easy way it automates operations of pumps depending on level.
- Control of level in wells, tanks, reservoirs...
- It is delivered as a connected set - easy installation.
- Possibility to monitor level of any type of conductive liquid.
- It serves for an automatic operation in 1-phased and 3-phased pumps.
- Set of level switch HRH-5 and a contactor VS425.
- Function choice - pumping up or down.
- Unit requires incoming over-current protection.
- Protection degree of the set is IP55.
- There is a possibility of 4 types of probes in a various design (they are not a part of this set, it is possible to deliver).
- Unit is placed in a plastic box with dimensions 160 x135 x 83 mm (6.3 x 5.3 x 3.3").

Function

Function PUMP UP

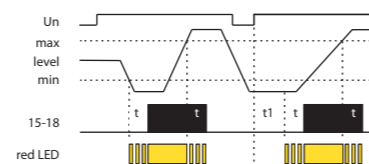

Function PUMP DOWN

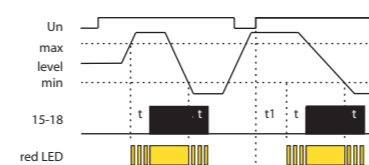

Connection

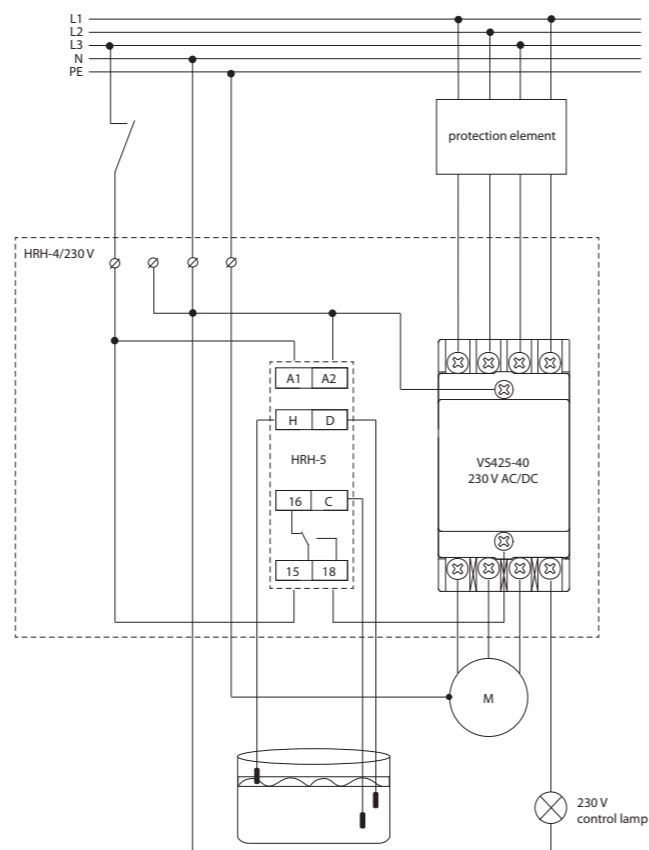

SHR-1-M, SHR-2-N, SHR-2, SHR-3 | Level sensors



EAN code
SHR-1-M: 8595188110105
SHR-2-N: 8595188111379



EAN code
SHR-2: 8595188111263



EAN code
SHR-3: 8595188111270

SHR-1-M: brass sensor

SHR-1-N: stainless steel sensor

- Sensor to control flooding.
- Electrode with diameter 4 mm (0.2") is placed in plastic cover.
- Panel or to holder mounting.
- Conductor is connected to terminal board, shrink bushing for feeder place insulation is a part of device.
- Max. wire profile: 2.5 mm² (AWG10).
- Installation: after connecting a wire to the sensor, run the shrink bushing over the wire onto the sensor.
- Heat the sensor and by shrinking the connection of sensor and wire will be hermetical.
- Weight: 9.7 g (0.3 oz.).
- Operating temperature: -25 °C to +60 °C (-13 °F to 140 °F).
- Total sensor length: 65.5mm (2.58").

Level probe SHR-2.

- Detection sensor is electrode, which in connection with switchable device is used for level detection for example in wells, tanks,....
- To be used in electric conductive fluids and mechanically polluted fluids with temperature: 1°C to 80°C (33.8 °F to 176°F).
- Stainless steel one-pole electrode reside in PVC cover, intended for tank wall mounting or mounting by socket.
- To ensure correct function of the sensor, it is necessary to have the electrode without dirt which could disable the connection of the electrode and fluid and thus lead to malfunction.
- Max. wire profile: 2.5 mm² (AWG 10).
- Recommended wire D05V-K0.75/3.2.
- Installation:
 - conductor wire is connected by feazing of two brass screws to stainless steel electrode.
 - conductor is caulked by bushing Pg7 with protection degree IP68.
- Weight: 48.6 g (1.7 oz.)
- Dimensions: max. diameter 21 mm (0.8"), length 96 mm (3.8").

SHR-2 in open state



Level probe SHR-3

- Stainless probe to be used into demanding industrial environments, designated for screwing into tank wall or cover.
- The probe is installed in horizontal, vertical or in sidelong position on tank side or in tank cover. Installation is done by soldering or by fixing nut. It is necessary to use 24 mm (1") screw. It is necessary to use an adequate torque with regards to a seal and operational overpressure in a tank.
- Sensor has connecting wire - length 3 m, which is connected to sensor to scan electrode and sensor bushing connecting wire is double-wire PVC AWG 18 (0.75 mm²), connection of wires: brown - scan electrode, blue - sensor bushing.
- Connection M18x1.5 screw.
- Protection degree IP 67.
- Sensor weight without cable: 100 g (3.3 oz.).
- Operating surroundings: place without the danger of detonation, temperature on screw: max. 95°C (203°F).
- Pressure immunity: on 25 °C (77 °F) 4 MPa, on 95 °C (203 °F) 1.5 MPa.
- Weight: 239 g (8.4 oz.).
- Material: bushing and scan electrode: stainless steel W.Nr. 1.4301, insulation insert of electrode: PTFE.
- Internal material: self-extinguishing epoxide resin.
- Operating temperature: -25 °C to 60 °C (-13 °F to 140 °F).
- Total sensor length: 65.5mm (2.58").
- Dimensions: see pg 134.

D03VV-F | Three-core cable



- Cable to probes SHR-1 and SHR-2, 3x 0.75 mm² (AWG 18) with a certification for drinking water, 1m (39.37").
- Construction:
 - bright copper stranded core of hole
 - core insulation of special PVC
 - sheath of special PVC.
- Technical specifications and usage:
 - the product meets requirements for direct and permanent contact with drinking water according to § 5 of the Act. 258/2000 Decree of the Ministry of Health. 409/2005 Sb., On hygienic requirements for products coming into direct contact with drinking water and water treatment
 - usable up to 70 °C (158 °F)
 - suitable for submersible conductivity probes for the boreholes, wells and tanks
 - suitable for probes used for level detection of conductive liquids.
 - cable capacity is max. 12.3 nF / 100 m (328')

EAN code
D03VV-F 3x0.75/3.2: 8595188165884

Technical parameters		D03VV-F 3x0.75/3.2
Rated voltage:		300 / 300 V
Test voltage:		2 kV
Capacity:		max. 12.3 nF / 100 m (328')
Core diameter with insulation:		3.2 mm (0.12")
Overall diameter of cable:		8.1 mm (0.31")
Section:		0.75 mm ² (AWG 18)
Length:		1 m (39.37")

Cross-section

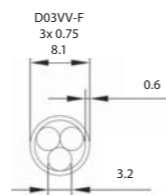

D05V-K | Power cable



- Cable to probes SHR-1 and SHR-2, 3x 0.75 mm² (AWG 18) with a certification for drinking water, 1m (39.37").
- Construction:
 - bright copper stranded core of hole
 - insulation of special PVC.
- Technical specifications and usage:
 - the product meets requirements for direct and permanent contact with drinking water according to § 5 of the Act. 258/2000 Decree of the Ministry of Health. 409/2005 Sb., On hygienic requirements for products coming into direct contact with drinking water and water treatment
 - usable up to 70 °C (158 °F)
 - suitable for probes used for level detection of conductive liquids.

EAN code
D05V-K 0.75/3.2: 8595188165945

Technical parameters		D05V-K 0.75/3.2
Rated voltage:		300 / 500 V
Test voltage:		2 kV
Capacity:		max. 12.3 nF / 100 m (328')
Core diameter with insulation:		3.2 mm (0.12")
Section:		0.75 mm ² (AWG 18)
Length:		1 m (39.37")

Analog

TER

- TER-3A**: -30 to 10 °C (-22 °F to 50 °F) external NTC.
- TER-3B**: 0 °C to 40 °C (32 °F to 104 °F) external NTC.
- TER-3C**: 30 °C to 70 °C (86 °F to 158 °F) external NTC.
- TER-3D**: 0 °C to 60 °C (32 °F to 140 °F) external NTC.
- TER-3E**: 0 °C to 60 °C (32 °F to 140 °F) external NTC.
- TER-3F**: 0 °C to 60 °C (32 °F to 140 °F) in-built NTC.
- TER-3G**: 0 °C to 60 °C (32 °F to 140 °F) external Pt100.
- TER-3H**: -15 °C to 45 °C (5 °F to 113 °F) external NTC.

TER-4: Wide and accurate range of setting -40 °C to 110 °C (-40 °F to 230 °F) in ten ranges in one device, fine temperature setting. 2 inputs for NTC sensor, 2 outputs 16 A changeover/SPDT, additional function (memory, hysteresis, indication of faulty sensor). Supply: AC 230 V or AC/DC 24 V (galv. separated).

TER-7: Monitoring heating of motor winding in range given by resistance of in-built PTC thermistor (1.8-3.3 kΩ), additional function (memory, reset), output contact 2x 8A changeover/DPDT, supply: AC/DC 24-240 V.

Thermo

- ATR**: Analog room thermostat with temperature range 5 to 40 °C (41 °F to 104 °F) night decline, flush mounted in to wiring box.
- ATF**: Analog floor thermostat with temperature range 5 to 50 °C (41 °F to 122 °F) ,temporary temperature change * in range ±10 °C / 50 °F.
- ATC**: Combined thermostat with room and floor sensor, temperature range 5 to 50 °C (41 °F to 122 °F).

TEV

- TEV-1**: Thermostat with „dead zone“, independent adjustable range -20 to 20 °C (-4 °F to 68 °F), protection against freezing, water-proof type IP65.
- TEV-2**: Thermostat for regulation of heating (cooling), adjustable range -20 to 20 °C (-4 °F to 68 °F), external sensor NTC, output contact 16A changeover/SPDT.
- TEV-3**: Thermostat for regulation of heating (cooling), adjustable range 5 to 35 °C (41 °F to 149 °F), external sensor NTC, output contact 16 A, control potentiometer and indication on panel.
- TEV-4**: Single exterior thermostat for monitoring and regulation of temperature in demanding environments. Temperature range: -30 °C to 60 °C (-30 °C to 140 °F)

Digital

Thermo

- DTR**: Digital room thermostat with temperature range 5 to 50 °C (41 °F to 122 °F) with in-built (internal) sensor. Intelligent regulation.
- DTF**: Digital floor thermostat with temperature range 5 to 50 °C (41 °F to 122 °F) with external sensor, 16 A potential-free contact.
- DTC**: Digital combined thermostat with room and floor sensor with temperature range 5 to 50 °C (41 °F to 122 °F), default programs.

TER

- TER-9**: 2 temperature inputs, 2 outputs 8A changeover/SPDT, 6 functions, in-built time switch clock, LCD with back light, galvanically sep. supply voltage AC 230 V or AC/DC 24V, 2 MODULE. Temperature range: -40 °C to 110 °C (-40 °C to 230 °F).

Therموالve

- ATV-1**: Energy-saving digital thermostat for radiators, with temperature range 8 to 28 °C (48 °F to 82 °F).

Accessories to thermostats

- Telva**: It is an appropriate control unit for a wide range of thermostatic valves.
- LKM-45**: Installation box for thermostat mounting on a surface.
- TC, TZ, Pt100**: External temperature sensors for thermostats in lengths 3m, 6m, 12m (9.9', 19.7', 39.4')
-TC/TZ: thermistor NTC 12 kΩ/ 25 °C (77 °F)
PT: element Pt100 (only TER-3G).

Hygrostat

- RHV-1**: Hygro-thermostat for humidity monitoring and regulation in range 0..90 % RH.

Hygro-thermostat

- RHT-1**: Hygro-thermostat for temperature monitoring and regulation in range 0 to 60 °C (32 °F to 140 °F) and relative humidity monitoring and regulation in range 50..90%.

Type	Design	Type				Sensor Type	Supply				Temperature range	Hysteresis	Relative humidity	Designation	Page of catalogue
		Analog	Digital	In-built	External		AC 230V	AC 24V	AC/DC 24 ..240V	Galv. separated					
TER-3A	1M-DIN	•	x	x	•	NTC	x	x	•	x	-30 ..10 °C (-22 °F to 50 °F)	0.5 - 5 °C (32.9 °F to 41 °F)	x	single thermostat into a switchboard with external sensor for temperature in cooling and against freezing	99
TER-3B	1M-DIN	•	x	x	•	NTC	x	x	•	x	0 .. 40 °C (32 °F to 104 °F)	0.5 - 5 °C (32.9 °F to 41 °F)	x	single thermostat into a switchboards with external sensor for sensing room and operational temperature	99
TER-3C	1M-DIN	•	x	x	•	NTC	x	x	•	x	+30 .. 70 °C (86 °F to 158 °F)	0.5 - 5 °C (32.9 °F to 41 °F)	x	single thermostat into a switchboards with external sensor for sensing temperature in devices (overheating...)	99
TER-3D	1M-DIN	•	x	x	•	NTC	x	x	•	x	0 .. 60 °C (32 °F to 140 °F)	0.5 - 5 °C (32.9 °F to 41 °F)	x	single thermostat into a switchboard with external sensor for sensing operational temperature of machines and devices	99
TER-3E	1M-DIN	•	x	x	•	NTC	x	x	•	x	0 .. 60 °C (32 °F to 140 °F)	1 °C (34 °F)	x	as TER-3D but with fixed hysteresis	100
TER-3F	1M-DIN	•	x	•	x	NTC	x	x	•	x	0 .. 60 °C (32 °F to 113 °F)	1 °C (34 °F)	x	single thermostat into a switchboard with in-built sensor, monitors operational temperature in a switchboard	100
TER-3G	1M-DIN	•	x	x	•	Pt100	x	x	•	x	0 .. 60 °C (32 °F to 140 °F)	0.5 - 5 °C (32.9 °F to 41 °F)	x	as TER-3D but with input for sensor Pt100	99
TER-3H	1M-DIN	•	x	x	•	NTC	x	x	•	x	-15 .. 45 °C (5 °F to 113 °F)	0.5 - 5 °C (32.9 °F to 41 °F)	x	as TER-3A but with a different temperature range - for cooling and heating	99
TER-4	3M-DIN	•	x	x	•	NTC (2x)	•	•	x	•	-40 .. 110 °C (-40 °F to 230 °F)	0.5 - 2.5 °C (32.9 °F to 37 °F)	x	two-state thermostat (2 inputs, 2 outputs), two independent or dependent thermostats, accurate setting, wide temperature range	101
TER-7	1M-DIN	•	x	x	•	PTC	x	x	•	x	x	Resistance 1.8-3.3 kΩ	x	thermistor relay for protection of motor overheating, input designated for sensor PTC in-built in motor winding	104
TER-9	2M-DIN	x	•	x	•	NTC (2x)	•	•	x	•	-40 .. 110 °C (-40 °F to 230 °F)	0.5 - 5 °C (32.9 °F to 41 °F)	x	multifunction (6thermo functions) digital thermostat with in-built time switch clock, 2 inputs/2 outputs	102
TEV-1	IP65 box	•	x	x	•	INTC	•	x	x	x	-20 .. 20 °C (-4 °F to 68 °F)	1.5 °C (35 °F)	x	thermostat with "dead zone", control of heating and protection against freezing, box for outdoor use with IP65	108
TEV-2	IP65 box	•	x	x	•	NTC	•	x	x	x	-20 .. 20 °C (-4 °F to 68 °F)	1.5 °C (35 °F)	x	single thermostat for regulation of heating, short sensor is a part of this device, protection degree IP65	109
TEV-3	IP65 box	•	x	x	•	NTC	•	x	x	x	5 .. 35 °C (41 °F to 149 °F)	1.5 °C (35 °F)	x	as TEV-2 but potentiometer and indication are placed on front panel	109
TEV-4	IP65 box	x	x	x	•	NTC	•	x	x	x	-30 .. 65 °C (-22 °F to 149 °F)	0.5 / 1.5 / 4 °C (32.9 / 35 / 39 °F)	x	single exteriors thermostat for monitoring and regulation of temperature in demanding environments	110
ATR	ELEGANT	•	x	•	x	NTC	•	x	x	x	5 .. 40 °C (41 °F to 104 °F)	1 °C (34 °F)	x	room analog thermostat line THERMO for mounting into a wiring box	105
ATF	ELEGANT	•	x	x	•	NTC	•	x	x	x	5 .. 50 °C (41 °F to 122 °F)	1 °C (34 °F)	x	floor analog thermostat line THERMO for mounting into a wiring box	105
ATC	ELEGANT	•	x	•	•	NTC	•	x	x	x	5 .. 50 °C (41 °F to 122 °F)	1 °C (34 °F)	x	room and floor (combined) analog thermostat line THERMO for mounting into a wiring box	105
DTR	ELEGANT	x	•	•	x	NTC	•	x	x	x	5 .. 50 °C (41 °F to 122 °F)	0.5 - 1 °C (32.9 °F to 34 °F)	x	room digital thermostat line THERMO for mounting into a wiring box	106
DTF	ELEGANT	x	•	x	•	NTC	•	x	x	x	5 .. 50 °C (41 °F to 122 °F)	0.5 - 1 °C (32.9 °F to 34 °F)	x	floor digital thermostat line THERMO for mounting into a wiring box	106
DTC	ELEGANT	x	•	•	•	NTC	•	x	x	x	5 .. 50 °C (41 °F to 122 °F)	0.5 - 1 °C (32.9 °F to 34 °F)	x	room and floor (combined) digital thermostat line THERMO for mounting into a wiring box	106
RHT-1	1M-DIN	•	x	•	x	built-in	x	x	•	x	0 .. 60 °C (32 °F to 140 °F)	H - 4 % T - 2.5 °C (36.5 °F)	50.. 90%	hygro-thermostat for temperature monitoring and regulation in range 0 °C to +60 °C (32 °F to 140 °F) and relative humidity in range 50.. 90%	111
RHV-1	IP65	•	x	•	x	built-in	x	x	x	x	-30 .. 60 °C (-22 °F to 140 °F)	2%, 3%, 4%	0 ... 30 % RH 30 ... 60 % RH 60 ... 90 % RH	hygro-thermostat for humidity monitoring and regulation in range 0.. 90 % RH	112
ATV-1	valve	x	•	•	x	built-in	x	x	x	x	8 .. 28 °C (46 °F to 82 °F)	x	x	thermostatic direction valves, temperature regulation +8 to +28 °C (46 °F to 82 °F)	107



EAN code
 TER-3A: 8595188138390
 TER-3B: 8595188138406
 TER-3C: 8595188138413
 TER-3D: 8595188138420
 TER-3G: 8595188138451
 TER-3H: 8595188138468

Technical parameters		TER-3
Function:	single level	
Supply terminals:	A1-A2	
Voltage range:	AC/DC 24 - 240V (galvanically unseparated) (AC 50-60Hz)	
Burden:	2 VA	
Operating range:	- 15 %; + 10 %	
Measuring circuit		
Measuring terminals:	T1 - T1	
Temperature range: (according to product type sensitivity)	TER-3A: -30 °C to 10 °C (-22 °F to 50 °F) TER-3B: 0 °C to 40 °C (32 °F to 104 °F) TER-3C: 30 °C to 70 °C (86 °F to 158 °F) TER-3D: 0 °C to 60 °C (32 °F to 140 °F) TER-3G: 0 °C to 60 °C (32 °F to 140 °F) TER-3H: -15 °C to 45 °C (5 °F to 113 °F)	
Hysteresis:	adjustable in range 0.5 to 5 °C / 0.9 to 9 °F	
Sensor:	external, thermistor NTC, except for TER-3G (Pt100)	
Sensor fault indication (short circuit / disconnect):	flashing red LED	
Accuracy		
Setting accuracy (mech.):	5 %	
Switching difference:	0.5 °C / 0.9 °F	
Temperature dependance:	< 0.1 % / °C (< 0.1 % / °F)	
Output		
Number of contacts:	1x NO-SPST (AgSnO ₂)	
Current rating:	16A / AC1, 10A / 24V DC	
Breaking capacity:	4000 VA / AC1, 300 W / DC	
Switching voltage:	250 V AC1 / 24 V DC	
Min. breaking capacity DC:	500 mW	
Output indication:	red LED	
Mechanical life:	3x10 ⁷	
Electrical life (AC1):	0.7x10 ⁵	
Other information		
Operating temperature:	-20 °C to 55 °C (-4 °F to 131 °F)	
Storage temperature:	-30 °C to 70 °C (-22 °F to 158 °F)	
Electrical strength:	2.5 kV (supply - output)	
Operating position:	any	
Mounting:	DIN rail EN 60715	
Protection degree:	IP40 from front panel / IP10 terminals	
Overvoltage category:	III.	
Pollution degree:	2	
Max. cable size (mm ²):	solid wire max. 2x 2.5 or 1x 4 with sleeve max. 1x 2.5 or 2x 1.5 (AWG 12)	
Dimensions:	90 x 17.6 x 64 mm (3.5" x 0.7" x 2.5")	
Weight:	73 g (2.6 oz.)	
Standards:	EN 60730-2-9, EN 61010-1	

Example of an order

Please specify a type of thermostat in your order (TER-3A, TER-3B .. or TER-3H) types differ in temperature range and supply voltage.

- Single thermostat for temperature monitoring and regulation in range -30 °C to +70 °C (-22 °F to 158 °F) in six ranges.
- It can be used for monitoring temperature e.g. in switchboards, heating systems, cooling systems, liquids, radiators, motors, devices, open spaces, etc.
- Function of short-circuit or sensor disconnection monitoring.
- Possibility to set function "heating"/"cooling" (setting is done by DIP switch).
- Adjustable hysteresis (sensitivity), switching by potentiometer in range 0.5 to 5 °C / 0.9 to 9 °F
- Choice of external temperature sensors with double insulation in standard lengths 3, 6 and 12 m (9.8', 19.7' and 39.4').
- It is possible to place sensor directly on terminal block - for temperature monitoring in a switchboard or in its surroundings.
- Multivoltage supply AC/DC 24 -240 V, not galvanically separated.
- Output contact 1x NO - SPST 16 A /250 V AC1.
- Red LED indicates status of output, green LED indicates energization of the device.
- 1-MODULE, DIN rail mounting.

Description

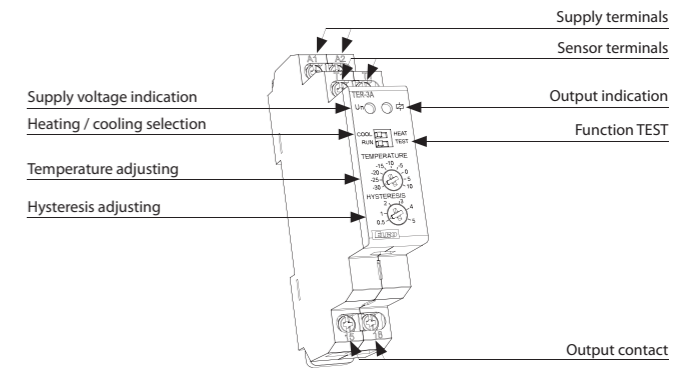

Function

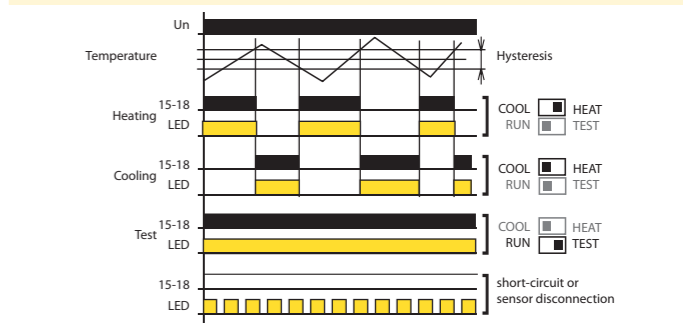

It is a single but practical thermostat with separated sensor for monitoring temperature. Device is placed in a switchboard and external sensor senses temperature of required space, object, or liquid. Supply is not galvanically separated from sensor. Sensor is double insulated. Maximal length of delivered sensor is 12 m / 39.4'. device has in-built indication of sensor damage, which means that in case of short-circuit or disconnection red LED flashes. Thanks to adjustable hysteresis, it is advantageous to regulate width of the range and thus define sensitivity of load switching. Sensed temperature is decreased by set hysteresis. When installing it is necessary to keep in mind that hysteresis is increased by temperature gradient between sensor's jacket and thermistor.

Connection Symbol

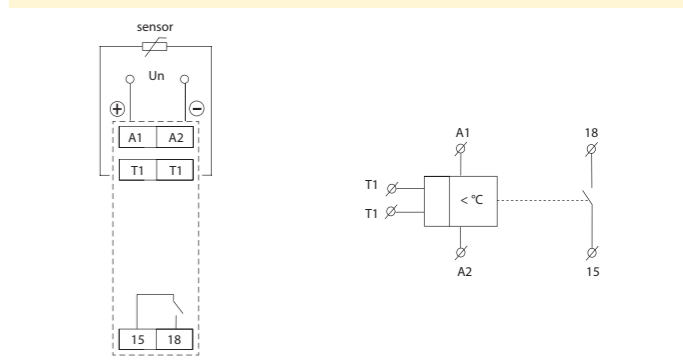



EAN code
TER-3E: 8595188138437
TER-3F: 8595188138444

Technical parameters	TER-3E	TER-3F
Function:	single level	
Supply terminals:	A1-A2	
Voltage range:	AC/DC 24 - 240 V (AC 50 - 60 Hz)	
Burden:	2 VA	
Operating range:	- 15 %; +10 %	
Measuring circuit		
Measuring terminals:	T1 - T1	x
Temperature range:	0 to +60 °C / (32 °F to 140 °F)	
Hysteresis:	fixed 1 °C / (1.8 °F)	
Sensor:	thermistor NTC	in-built
Sensor fault indic. (short-circuit / disconnection):	flashing red LED	
Accuracy		
Setting accuracy (mech.):	5 %	
Switching difference:	0.5 °C (0.9 °F)	
Temperature dependence:	< 0.1 % / °C (°F)	
Output		
Number of contacts:	1x NO- SPST (AgSnO ₂)	
Current rating:	16A / AC1, 10 A / 24 V DC	
Breaking capacity:	4000 VA / AC1, 300 W / DC	
Switching voltage:	250 V AC1 / 24 V DC	
Min. breaking capacity DC:	500 mW	
Output indication:	red LED	
Mechanical life:	3x10 ⁷	
Electrical life (AC1):	0.7x10 ⁵	
Other information		
Operating temperature:	-20 °C to 55 °C (-4 °F to 131 °F)	
Storage temperature:	-30 °C to 70 °C (-22 °F to 158 °F)	
Electrical strength:	2.5 kV (supply - output)	
Operating position:	any	
Mounting:	DIN rail EN 60715	
Protection degree:	IP40 from front panel / IP10 terminals	
Overvoltage category:	III.	
Pollution degree:	2	
Max. cable size (mm ²):	solid wire max. 2x 2.5 or 1x 4 with sleeve max. 1x 2.5 or 2x 1.5 (AWG 12)	
Dimensions:	90 x 17.6 x 64 mm (3.5" x 0.7" x 2.5")	
Weight:	73 g (2.58 oz.)	74 g (2.61 oz.)
Standards:	EN 60730-2-9, EN 61010-1	

- Single thermostat for temperature monitoring and regulation in range 0 to +60 °C (32 °F to 140 °F).
- It can be used for temperature monitoring e.g. in switchboards, heating systems, liquids, radiators, motors, devices, open spaces, etc.
- Fixed hysteresis at 1 °C / (1.8 °F).
- TER-3E: choice of external temperature sensors with double insulation in standard lengths 3 (9.8'), 6 (19.7') and 12 m (39.4').
- TER-3F: sensor is a part of device, serves for monitoring temperature in a switchboard.
- Supply voltage AC /DC 24 - 240 V.
- Output contact 1x NO- SPST 16 A / 250 V AC1.
- Output status is indicated by red LED.
- 1-MODULE, DIN rail mounting.

Description

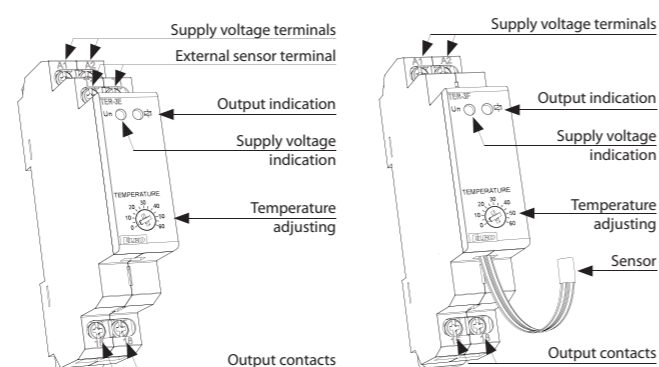

Function

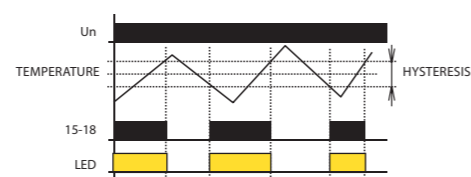

It is a single thermostat for temperature monitoring with separated sensor (except for TER-3F). Device is located in a switchboard and external sensor senses temperature of required space, object or liquid. Supply is not galvanically separated from sensor but sensor is double insulated. Maximal length of sensor cable is 12 m (39.4'). Temperature sensing is decreased by set hysteresis. When installing it is necessary to keep in mind that hysteresis is increased by temperature gradient between sensor's jacket and thermistor.

Connection

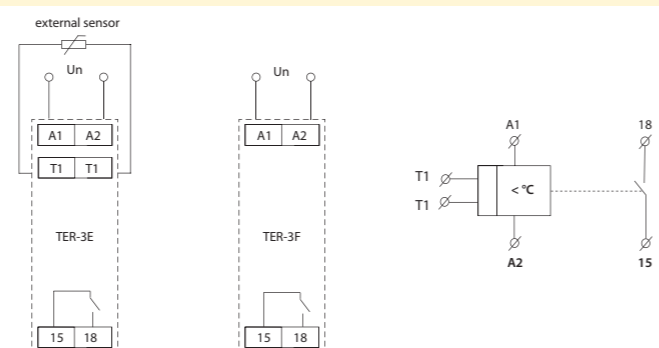

Example of an order

Please specify a type of thermostat in your order (TER-3E, TER-3F).



EAN code
TER-4 /230V: 8594030337806
TER-4 /24V: 8594030338148

Technical parameters	TER-4
Function:	double thermostat
Supply terminals:	A1-A2
Voltage range:	AC 230 V (AC 50-60 Hz), AC/DC 24V galvanically separated
Burden:	max. 4.5 VA
Supply voltage tolerance:	- 15 %; + 10 %
Measuring circuit	
Measuring terminals:	T1-T1 and T2-T2
Temperature ranges (set via switch individually for each level):	-40 to -25 °C / -40 to 77 °F 35 to 50 °C / 95 to 122 °F -25 to -10 °C / 77 to 50 °F 50 to 65 °C / 122 to 149 °F -10 to 5 °C / 50 to 41 °F 65 to 80 °C / 149 to 176 °F 5 to 20 °C / 41 to 70 °F 80 to 95 °C / 176 to 203 °F 20 to 35 °C / 70 to 95 °F 95 to 110 °C / 203 to 230 °F
Fine temperature setting:	0-15 °C, in selected range
Hysteresis for T1:	adjustable, 0.5 or 2.5 °C / 0.9 or 4.5 °F (DIP switch)
Hysteresis for T2:	adjustable, 0.5 or 2.5 °C / 0.9 or 4.5 °F (DIP switch)
Sensor:	thermistor NTC 12 kΩ / 25 °C (77 °F)
Sensor failure indication:	yellow LED
Accuracy	
Setting accuracy (mech.):	5 %
Repeat accuracy:	1 °C / (1.8 °F)
Temperature dependence:	< 0.1 % / °C (°F)
Output	
Number of contacts:	2x changeover/ SPDT (AgNI / Silver Alloy)
Current rating:	16A / AC1
Breaking capacity:	4000 VA / AC1, 384 W / DC
Inrush current:	30 A / < 3 s
Switching voltage:	250 V AC1 / 24 V DC
Min. breaking capacity DC:	500 mW
Output indication:	red LED
Mechanical life:	3x10 ⁷
Electrical life (AC1):	0.7x10 ⁵
Other information	
Operating temperature:	-20 °C to 55 °C (-4 °F to 131 °F)
Storage temperature:	-30 °C to 70 °C (-22 °F to 158 °F)
Electrical strength:	4 kV (supply - output)
Operating position:	any
Mounting:	DIN rail EN 60715
Protection degree:	IP40 from front panel / IP20 terminals
Overvoltage category:	III.
Pollution degree:	2
Max. cable size (mm ²):	solid wire max. 1x 2.5 or 2x 1.5 / with sleeve max. 1x 1.5 (AWG 12)
Dimensions:	90 x 52 x 65 mm (3.5" x 2" x 2.6")
Weight:	238 g (8.4 oz.)
Standards:	EN 60730-2-9, EN 61010-1

Symbol

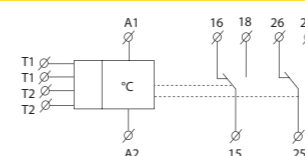

- Two-state thermostat for temperature monitoring and regulation in a wide range -40 °C to +110 °C (-40 °F to 230 °F) with a switch for temperature ranges shift and fine temperature setting (high accuracy of setting).
- It can be used for temperature monitoring in e.g. switchboards, heating systems, cooling systems, open spaces, objects, liquids, radiators, etc.
- 2 thermo inputs for sensor NTC 12 kΩ / 25 °C (77 °F).
- Possibility to choose if both thermostats should work independently or dependently (by DIP switch).
- Function of short-circuit or sensor disconnection monitoring.
- Possibility to set functions "heating" / "cooling" (setting is done by DIP switch).
- Adjustable hysteresis (sensitivity) of switching 0.5 or 2.5 °C (0.9 or 4.5 °F) (DIP switch).
- Choice of external thermo sensors with double insulation in standard lengths 3, 6 and 12 m (9.8', 19.7' and 39.4').
- It is possible to place the sensor directly on terminal block - to monitor temperature in a switchboard or in its surroundings.
- Galvanically separated supply AC 230 V or AC/DC 24 V.
- 2 independent output with changeover contacts/ SPDT 16 A / 250 V AC1.
- Output status indicated by red LED, faulty status of sensor by yellow LED.
- 3-MODULE, DIN rail mounting.

Description

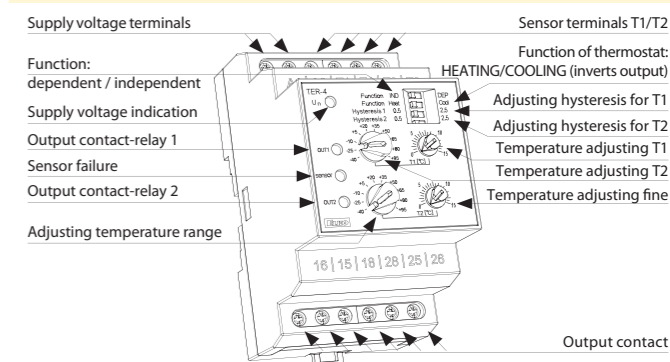

Function

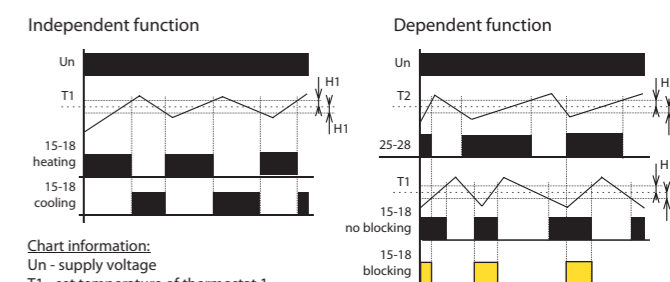

Chart information:

Un - supply voltage
T1 - set temperature of thermostat 1
T2 - set temperature of thermostat 2
H1 - set hysteresis of thermostat 1
H2 - set hysteresis of thermostat 2
15-18 output contact of thermostat 1
25-28 output contact of thermostat 2

Blocking function:

When DIP switch 4 is in position ON, condition for thermostat switching is switching output 15-18 at both individual thermostats (series function). Thus it is possible to use e.g. first thermostat as operational and the other as an emergency one. Output 25-28 operates normally, according to T2.

Connection

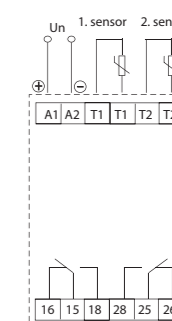

This device includes 2 thermostats in one. Thermostat has 2 thermo inputs, 2 outputs and individual temperature setting. It offers two possibilities of use. Firstly it can be used as two individual thermostats (e.g. for monitoring two temperature levels of one device or as a control of individual devices), secondly it is possible to set depending function of both thermostats, when thermostat 2 blocks thermostat No.1 Advantage of this thermostats is a wide temperature range - 40... 110°C (-40 to 230 °F) (in one device) with very good mechanical accuracy of setting. It is due to 10-state switch for thermo ranges and its scale by 15°C (27 °F). It is possible to use fine tuning by potentiometer by 0-15°C (0-27 °F) with accuracy ±1°C (1.8 °F). Device has in-built control of sensor fault (yellow LED). It is possible to set hysteresis 0.5 or 2.5 °C (0.9 or 4.5 °F).

It is possible to operate the thermostat only with one sensor. In that case it is necessary to connect a resistor 10 kΩ to the other input. This is included in the package.



EAN code
TER-9 /230V: 8595188124478
TER-9 /24V: 8595188129190

Technical parameters		TER-9
Supply		
Number of function:	6	
Supply terminals:	A1 - A2	
Voltage range:	AC 230 V (AC 50 - 60 Hz) galvanically separated, AC/DC 24V galvanically unseparated	
Burden:	max. 4 VA	
Operating range:	-15 %; +10 %	
Type backup battery:	CR 2032 (3V)	
Measuring circuit		
Measuring terminals:	T1-T1 and T2-T2	
Temperature range:	-40..+110 °C (-40..+230 °F)	
Hysteresis (sensitivity):	in an adjustable range 0.5.. 5 °C (0.9.. 9 °F)	
Difference temperature:	adjustable 1.. 50 °C (34..122 °F)	
Sensor:	thermistor NTC 12 kΩ at 25 °C (77 °F)	
Sensor failure indication:	displayed on the LCD	
Accuracy		
Measuring accuracy:	5 %	
Repeat accuracy:	< 0.5 °C (0.9 °F)	
Temperature dependence:	< 0.1 % / °C (°F)	
Output		
Number of contacts:	1x changeover for each output / SPDT, (AgNi)	
Current rating:	8 A / AC1	
Max. breaking capacity:	2000 VA / AC1, 240 W / DC	
Switching voltage:	250 V AC1 / 30 V DC	
Output indication:	symbol ON/OFF	
Mechanical life:	1x10 ⁷	
Electrical life (AC1):	1x10 ⁵	
Time circuit		
Power back-up:	up to 3 year	
Accuracy:	max. ±1 s per day, at 23°C (73.4 °F)	
Min. switching interval:	1 min	
Data stored for:	min. 10 years	
Program circuit		
Number of memory places:	100	
Program:	daily, weekly, yearly	
Data readout:	LCD display, with backlight	
Other information		
Operating temperature:	-10 °C to 55 °C (14 °F to 131 °F)	
Storage temperature:	-30 °C to 70 °C (-22 °F to 158 °F)	
Electrical strength:	4 kV (power supply - output)	
Operating position:	any	
Mounting:	DIN rail EN 60715	
Protection degree:	IP20 terminals, IP40 from front panel	
Overvoltage category:	III.	
Pollution degree:	2	
Max. cable size (mm ²):	solid wire max.1x 2.5 or 2x1.5 / with sleeve max. 1x2.5 (AWG 12)	
Dimensions:	90 x 35.6 x 64 mm (3.5 x 1.4 x 2.5")	
Weight:	(230 V) 127 g (4.4 oz.) (24 V) 120 g (4.2 oz.)	
Standards:	EN 61812-1; EN 61010-1; EN 60730-2-9; EN 60730-1; EN 60730-2-7	

- Digital thermostat with 6 functions and built-in time switch clock with day, week and year program. You can also limit temperature functions and courses this way in real time.
- Complex control of home and water heating, solar heating, etc.
- Two thermostats in one, two temperature inputs, two outputs with dry contact.
- Maximum universal and variable thermostat including all ordinary thermostat functions.
- Functions: two independent thermostats, dependent thermostat, differential thermostat, two level thermostat, zone-based thermostat, dead zone thermostat.
- Program setting of output functions, calibration of sensors according to reference temperature (offset).
- The thermostat is subject to the digital clock programs.
- Wide operating range of temperature settings, the possibility of measuring in °C and °F.
- Clear display of set and measured data on a backlit LCD.
- Power supply: AC 230 V or 24 V AC/DC (based on type of device).
- The time switch clock has a battery backup, which retains data in case of a power outage (reserve backup time - up to 3 years).
- Easy replacement of the backup battery through the plug-in module, no disassembling is required.
- Output contact 1x changeover / SPDT 8 A / 250 V AC1 for each output.
- 2-MODULE, DIN rail mounting.

Device description

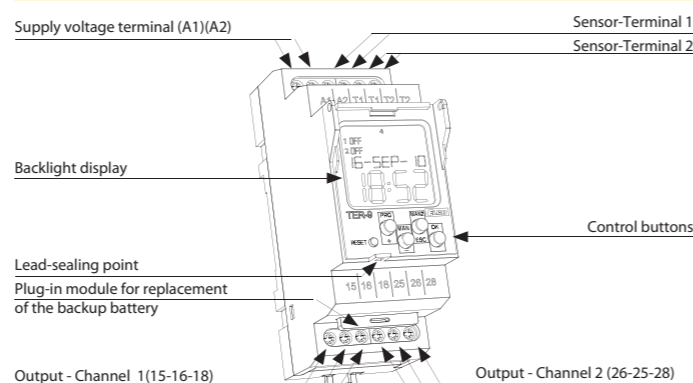

Description of visual elements on the display

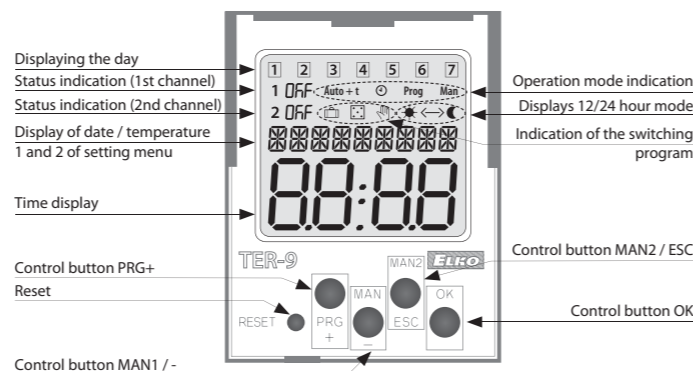

Connection Symbol

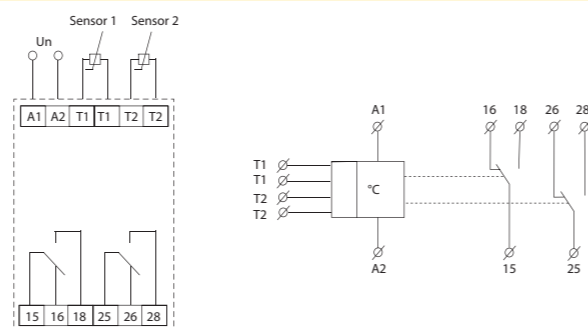

2 independent single-stage thermostats

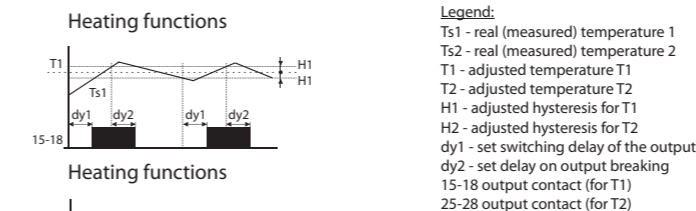

Legend:
Ts1 - real (measured) temperature 1
Ts2 - real (measured) temperature 2
T1 - adjusted temperature T1
T2 - adjusted temperature T2
H1 - adjusted hysteresis for T1
H2 - adjusted hysteresis for T2
dy1 - set switching delay of the output
dy2 - set delay on output breaking
15-18 output contact (for T1)
25-28 output contact (for T2)

Classic function of thermostat, output contact switched until adjusted temperature is reached. Hysteresis eliminates frequent switching - output oscillation.

Depending functions of 2 thermostats

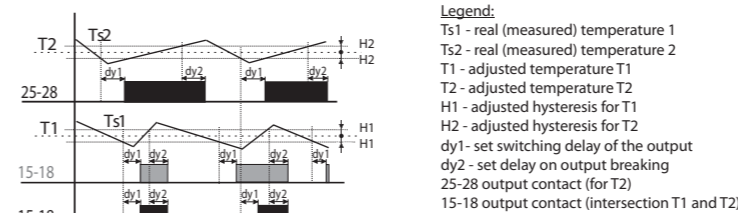

Legend:
Ts1 - real (measured) temperature 1
Ts2 - real (measured) temperature 2
T1 - adjusted temperature T1
T2 - adjusted temperature T2
H1 - adjusted hysteresis for T1
H2 - adjusted hysteresis for T2
dy1 - set switching delay of the output
dy2 - set delay on output breaking
25-28 output contact (for T2)
15-18 output contact (intersection T1 and T2)

Output 15-18 is closed, if temperature of both thermostats is below an adjusted level. When any thermostat reaches adjusted level, the contact 15-18 opens. Serial inner connection of thermostats (logic function AND).

Differential thermostat

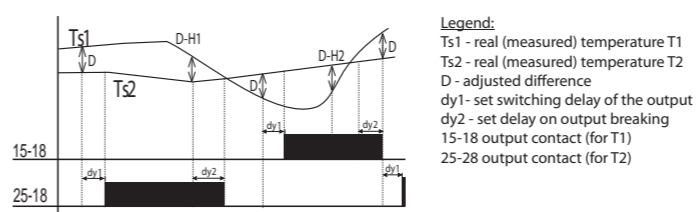

Legend:
Ts1 - real (measured) temperature T1
Ts2 - real (measured) temperature T2
D - adjusted difference
dy1 - set switching delay of the output
dy2 - set delay on output breaking
15-18 output contact (for T1)
25-28 output contact (for T2)

Switching of output corresponds with input, which has lower temperatures when difference is exceeded. Differential thermostat is used for keeping two identical temperature e.g. in heating systems (boiler and reservoir), solar systems (collector - reservoir, exchanger), water heating (water heater, water distribution)etc.

2-stage thermostat

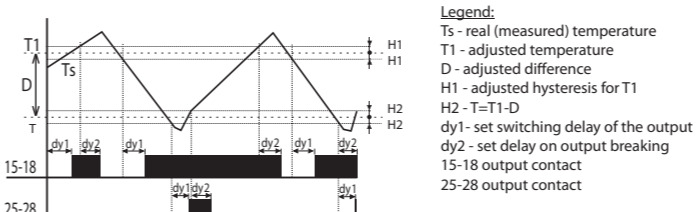

Legend:
Ts - real (measured) temperature
T1 - adjusted temperature
T2 - adjusted temperature
D - adjusted difference
H1 - adjusted hysteresis for T1
H2 - T1-D
dy1 - set switching delay of the output
dy2 - set delay on output breaking
15-18 output contact
25-28 output contact

Typical example of use for two-stage thermostat is e.g. in boiler-room, where there are two boilers from which one is main and the other one is auxiliary. The main boiler is managed according to set temperature and auxiliary boiler is switched in case temperature falls under set difference. Thus it helps to the main boiler in case outside temperature dramatically falls. In the range of set difference (D) output 15-18 functions as normal thermostat to input 1 (type 1). In case temperature falls under set difference, second output switches too.

Thermostat with "WINDOW"

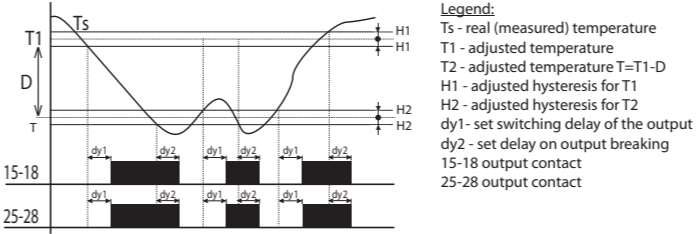

Legend:
Ts - real (measured) temperature
T1 - adjusted temperature
T2 - adjusted temperature T=T1-D
H1 - adjusted hysteresis for T1
H2 - adjusted hysteresis for T2
dy1 - set switching delay of the output
dy2 - set delay on output breaking
15-18 output contact
25-28 output contact

Output is closed (heating) only if temperature is within adjusted range. If temperature is out of range, the contact opens. T is set as T1-D. The function is used for protection of gutters against freezing.

Thermostat with dead zone

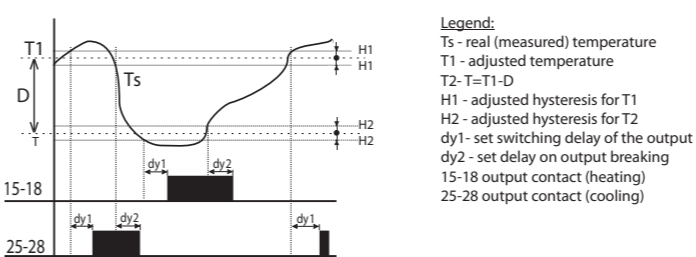

Legend:
Ts - real (measured) temperature
T1 - adjusted temperature
T2 - T1-D
H1 - adjusted hysteresis for T1
H2 - adjusted hysteresis for T2
dy1 - set switching delay of the output
dy2 - set delay on output breaking
15-18 output contact (heating)
25-28 output contact (cooling)

In case of thermostat with a „dead zone“, it is possible to set temperature T1 and a difference (respectively a width of dead zone D). If temperature is higher than T1, output contact of cooling switches ON; if the temperature gets below T1, the contact switches OFF. If the temperature gets below temperature T, the contact of heating switches ON and it switches OFF when temperature T is exceeded. This function can be used for example for automatic air warming and cooling in ventilation so the sit is always within the range T1 and T.



EAN code
TER-7: 8595188137164

Technical parameters		TER-7
Function:	monitoring temperature of motor winding	
Supply terminals:	A1-A2	
Voltage range:	AC/ DC 24 - 240 V (AC 50 - 60 Hz)	
Burden:	max. 2 VA	
Operating range:	-15 %; +10 %	
Measuring circuit		
Measuring terminals:	Ta-Tb	
Cold sensor resistance:	50 Ω - 1.5 kΩ	
Upper level:	3.3 kΩ	
Bottom level:	1.8 kΩ	
Sensor:	PTC temperature of motor winding	
Sensor failure indication:	blinking red LED	
Accuracy		
Accuracy in repetition:	< 5 %	
Switching difference:	± 5 %	
Temperature dependence:	< 0.1 % / °C	
Output		
Number of contacts:	2x changeover / DPDT (AgNi / Silver Alloy)	
Current rating:	8 A / AC1	
Breaking capacity:	2000 VA / AC1, 192 W / DC	
Inrush current:	10 A / < 3 s	
Switching voltage:	250 V AC1 / 24 V DC	
Min. breaking capacity DC:	500 mW	
Mechanical life:	3x10 ⁷	
Electrical life (resistive):	0.7x10 ⁵	
Other information		
Operating temperature:	-20 °C to 55 °C (-4 °F to 131 °F)	
Storage temperature:	-30 °C to 70 °C (-22 °F to 158 °F)	
Electrical strength:	4 kV (supply - output)	
Operating position:	any	
Mounting:	DIN rail EN 60715	
Protection degree:	IP40 from front panel / IP20 terminals	
Overvoltage category:	III.	
Pollution degree:	2	
Max. cable size (mm ²):	solid wire max. 1x 2.5 or 2x 1.5 / with sleeve max. 1x 2.5 (AWG 12)	
Dimensions:	90 x 17.6 x 64 mm (3.5" x 0.7" x 2.5")	
Weight:	83 g (2.9 oz.)	
Standards:	EN 60730-2-9, EN 61010-1	

Note

Sensors could be in series in abide with conditions in technical specification - switching limits.

Warning!: In case of supply from the main, neutral wire must be connected to terminal A2.

- It monitors motor coil temperature.
- Fixed levels of switching.
- PTC sensor is used for sensing, it is in-built in motor winding by its manufacturer or there is used an external PTC sensor.
- MEMORY function - relay is blocked in an error state until operator intervention (press RESET button).
- RESET of faulty state:
 - a) button on the front panel
 - b) by external contact (remote by two wires).
- Function of short-circuit or sensor disconnection monitoring, red LED flashing indicates faulty sensor.
- Output contact: 2x changeover / DPDT 8 A / 250 V AC1.
- Red LED shines and indicates exceeded temperature.
- Terminals of sensor are galvanically separated, they can be shorted out by terminal PE without damaging the device.
- Multivoltage supply AC/DC 24 - 240 V.
- 1-MODULE, DIN rail mounting.

Description

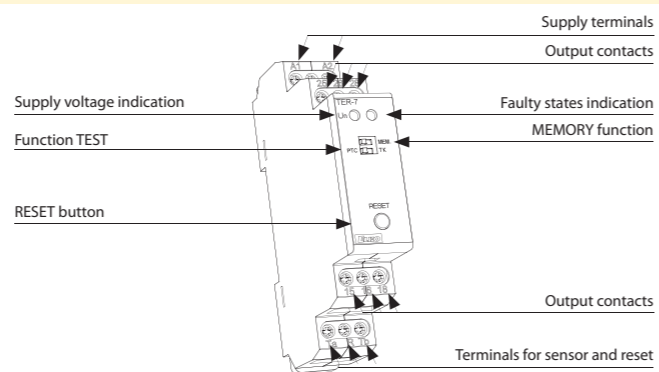

Function

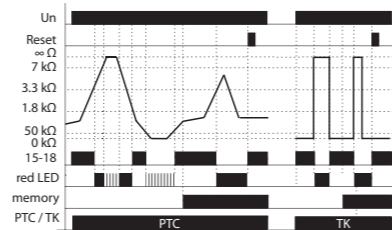

The device controls temperature of motor winding with PTC thermistor which is mostly placed in motor winding or very close to it. Resistance of PTC thermistor run to max 1.5 kΩ in cold stage. By temperature increase the resistance goes strongly up and by overrun the limit of 3.3 kΩ the contact of output relay switch off - mostly contactor controlling a motor. By temperature decrease and thereby decrease of thermistor resistance under 1.8 kΩ the output contact of relay again switches on. The relay has function "Control of sensor fault". This controls interruption or disconnection of sensor. When switch is in position "TK" monitoring of faulty sensor is not functional - it is possible to connect bimetal sensor with only 2 states: ON or OFF. The device can work with bi-metal sensor in this position. Other safety unit is function "Memory". By temperature overrun (and output switches off) the output is hold in faulty stage until service hit. This brings the relay to normal stage (with RESET button) on front panel or by external contact (remote).

Connection

Symbol

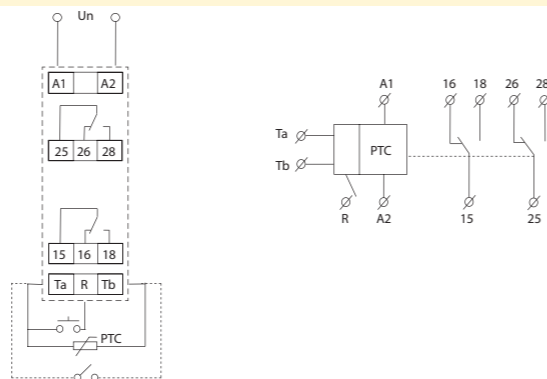

EAN code - DEVICE:
ATR: 8595188125000
ATF: 8595188130165
ATC: 8595188130172
To devices is necessary to order additionally - frame in design ELEGANT and external sensor (except ATR)

EAN code - SET:
ATR, white frame Elegant: 8595188136228
ATF, white frame Elegant, termosensor TC-3m: 8595188135870
ATC, white frame Elegant, termosensor TC-3m: 8595188135887

Technical parameters	ATR	ATF	ATC
Supply			
Power supply and tolerance:	AC 230 V ± 10 %		
Consumption, frequency:	6.5 VA/ 50 - 60 Hz		
Measuring			
Temperature range:	5 to 40 °C (41 °F to 104 °F)	5 to 50 °C (41 °F to 122 °F)	
Accuracy:	± 2 °C / 36 °F		
Hysteresis:	± 1 °C / 34 °F		
Temperature sensor:	room	floor	room + floor
Night decline:	adj. ± 7 °C / 45 °F	adj. ± 10 °C / 50 °F	fix - 5 °C / 41 °F
Offset / calibration:	adj. ± 7 °C / 45 °F		adj. ± 10 °C / 50 °F
Setting			
Room temperature setting:	main knob	x	main knob
Floor temperature setting:	x	main knob	auxiliary button 2
Offset setting:	auxiliary button 1		
Night decline setting:	auxiliary button 2		x
Night decline switching:	internal / external	internal pushbutton	
Display			
Power supply indication:	green LED 1		
Output ON indication:	red LED 1		
Night decline indication:	red / orange LED 2	red LED 2	
Indication of faulty floor sensor:	x	LED 1 flashing	
Indication - exceeded temp. / ext. sensor:	x		LED 1 flashing
Output			
Type:	potential-free contact NO-SPST, material of contact - AgNi		
Max. loadability:	16 A / 250 V, 4000 VA for AC1		
Contact separation:	galvanic		
Mechanical life:	3x10 ⁷		
Electrical life (AC1):	0.7x10 ⁵		
Other information			
Operating temperature:	-10 °C to 55 °C (14 °F to 131 °F)		
Storage temperature:	-20 °C to 70 °C (-4 °F to 158 °F)		
Electrical strength:	4 kV		
Mounting:	installation box with min. depth 30 mm / 1.18", Ø min. 65 mm / 2.6"		
Protection degree:	IP 30 in standard conditions*		
Max. cable size (mm ²):	solid wire 1x 2.5 / 1.5 with sleeve (AWG 12)		
Dimensions:	84 x 89 x 56.4 mm (3.3" x 3.5" x 2.22")		
Weight:	110 g (3.9 oz.)		
Standards:	EN 60730-2-9, EN 61010-1		

* - see page 38

Accessories

See page 114.

- **ATR** - Analog Thermo Room:
 - Room thermostat with temperature range 5 to 40 °C (41 °F to 104 °F) with a built-in sensor.
- **ATF** - Analog Thermo Floor:
 - Floor thermostat with temperature range 5 to 50 °C (41 °F to 122 °F) with external sensor.
 - Function „temporary temperature change“ in range ±10 °C (50 °F) (decreasing / increasing temperature).
- **ATC** - Analog Thermo Combined:
 - Room and floor thermostat, sensors are connected in series and block each other.
 - Function „temporary temperature change“, fix -5 °C / 23 °F (night decline).
 - Temperature range 5 to 50 °C (41 °F to 122 °F) for both sensors, adjustable separately.
 - It is possible to use it without external sensor.

- **ATR, ATF, ATC**
 - Night decline is activated by a pushbutton on device or external contact (only ATR).
 - Night decline setting is done by an auxiliary button 2 (under main button, only ATR/ATF).
 - Offset setting (calibration ± 10 °C / 50 °F) with „known“ thermometer.
 - External sensor (TC-3.3 m / 9.84') is a part of delivery (only ATF/ATC), it is possible to extend its length up to 100 m (328').
 - Design ELEGANT®, wide range of colors, possibility to combine more frames together.

Description

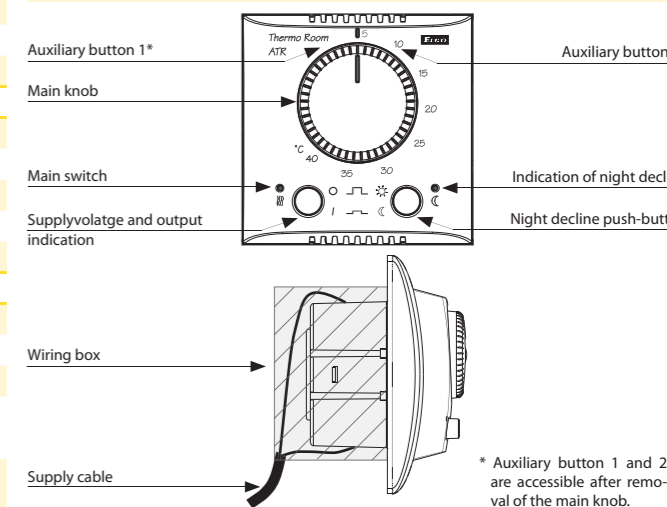

Connection

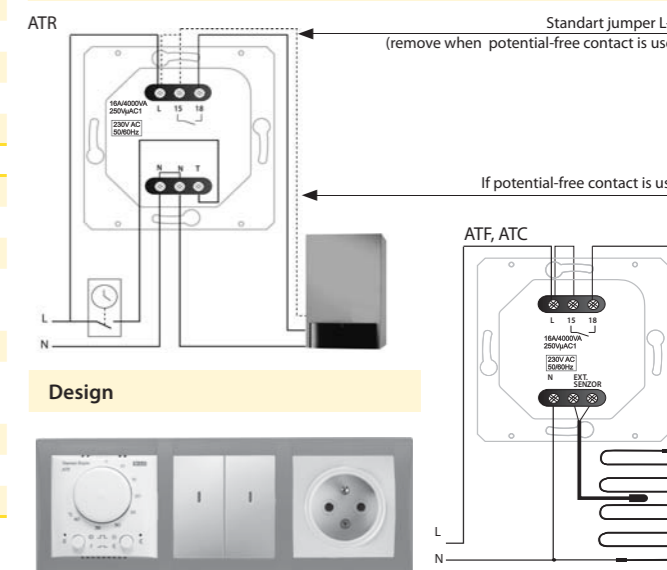

Design



Complete offer of switching devices line ELEGANT can be found in an individual catalogue ELEGANT Home switches, which can be sent to you upon request.



EAN code - DEVICE:
DTR: 8595188125017
DTF: 8595188135924
DTC: 8595188135931
To devices is necessary to order additionally - frame in design ELEGANT and external sensor (except DTR)

EAN code - SET:
DTR, white frame Elegant: 8595188136235
DTF, white frame Elegant, termosensor TC-3m: 8595188135863
DTC, white frame Elegant, termosensor TC-3m: 8595188135856

Technical parameters	DTR	DTF	DTC
Supply			
Power supply and tolerance:	AC 230 V ± 15 %		
Consumption, frequency:	1.5 VA, 50 - 60 Hz		
Backup:	rechargeable accumulator LIR2032 (40 mAh) charging time from 0 to 100 %: 3 hours backup time when capacity is 100 %: 72 hours		
Measuring			
Temperature range:	5 to 50 °C (41 to 122 °F)		
Accuracy:	± 0.5 °C (± 32.9 °F)		
Hysteresis:	adjustable 0.5 °C or 1 °C (32.9 or 33.8 °F)		
Temperature sensor:	room (internal)	floor (external)	room (internal) and floor (external)
Adjusting			
Min. temperature cycle:	0.5 °C (32.9 °F)		
Min. time cycle:	10 min.		
Number of programs:	4; pre- set program 1		
Number of events:	2 - 6 in a program		
Offset / calibration:	adjustable ± 0.5 °C (32.9 °F)		
Display			
LCD display:	26 x 24 mm, with backlight (ON or OFF permanently)		
Displaying date:	current time, set / current temperature, day in a week, output status		
Output indication:	red LED and symbol on LCD		
Output			
Type:	potential- free contact NO - SPST, material of contact - AgNi (Silver Allow)		
Max. loadability:	16 A / 250 V, 4000 VA by AC1		
Contact separation:	galvanic, electrical strength 4 kV		
Mechanical life:	3x10 ⁷		
Electrical life:	0.7x10 ⁵		
Other information			
Operating position:	-10 °C to 55 °C (14 °F to 131 °F)		
Storing position:	-20 °C to 70 °C (-4 °F to 158 °F)		
Electical strenght:	4 kV		
Mounting:	wiring box with min. depth 30 mm / 1.18 ", Ø min. 65 mm / 2.6 "		
Protection degree:	IP 30 in standard conditions*		
Max. cable size (mm ²):	solid wire 1x 2.5 / 1.5 with sleeve (AWG 12)		
Dimensions:	84 x 89 x 54.3 mm (3.3 " x 3.5 " x 2.14 ")		
Weight:	120 g (0.26 oz.)		
Standards:	EN 60730-2-9, EN 61812-1, EN 61010-1		

* - see page 38

Design

Complete offer of switching devices line ELEGANT can be found in an individual catalogue ELEGANT Home switches, which can be sent to you upon request.

- DTR - Digital Thermo Room:**
 - Room thermostat with temperature range 5 to 50 °C (41°F to 122 °F) with a built-in sensor.
- DTF - Digital Thermo Floor:**
 - Floor thermostat with temperature range 5 to 50 °C (41 °F to 122 °F) with external sensor.
- DTC - Digital Thermo Combined:**
 - Combined thermostat with room and floor sensors and temperature range 5 to 50 °C (41 °F to 122 °F).
 - Choice of temperature display from internal or external sensors.
 - By program it is possible to choose, which sensor is active and if it should function in serial or in parallel.
- DTF, DTC**
 - External sensor (TC-3, 3m) is a part of delivery (only ATF/ATC), it is possible to extend its length up to 100 m (328').
 - Monitoring of disconnection or short-circuit of external sensor, fault is displayed.

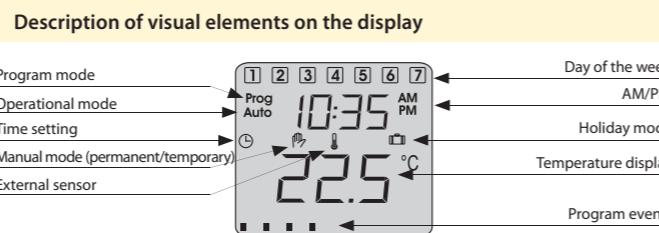
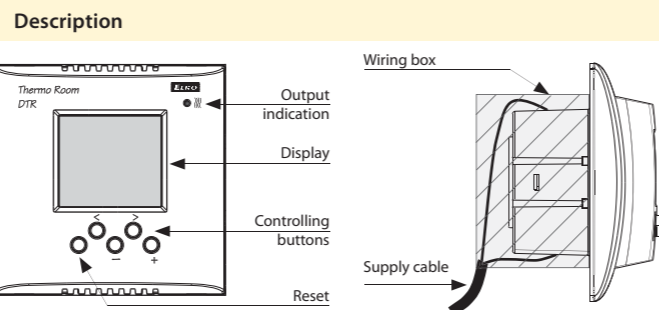

- Other functions of DTR, DTF, DTC**
- rechargeable backup battery in case of power failure (e.g. the high tariff of electric heating)
 - push-button lock to prevent unwanted manipulation with thermostat
 - the possibility of display settings - current or set temperature
 - „freezing protection“ in case temperature drops below 5 °C (41 °F) thermostat always switches heating on
 - choice of function heating or cooling
 - easy and intuitive control by four push-buttons
 - automatic shift summer / winter time
 - holiday mode - it is possible to set temperature and time from 1 hour to 99 days without any intervention into program settings or turning heating off (suitable in case of planned absence holiday...)
 - wall switch buttons in ELEGANT design, wide variety of colors and combination of multiframes

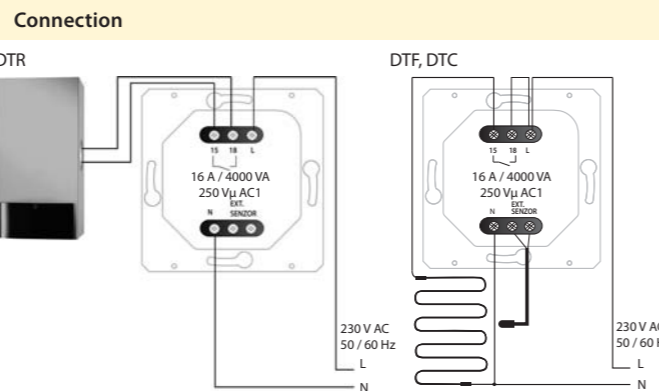

Accessories

See page 114.



EAN code
ATV-1: 8595188160889
USB programming adapter: 8595188160995

Technical parameters	ATV-1
Operating voltage:	3 V / DC (2 AA batteries 1.5 V / DC AA)
Temperature range:	8 to 28 °C (46 to 82 °F)
Color:	white
Dimensions (L x W x H):	76.5 x 53.5 x 63 mm (3" x 2.1" x 2.4")
Design:	thermostatic direction valves, electronic

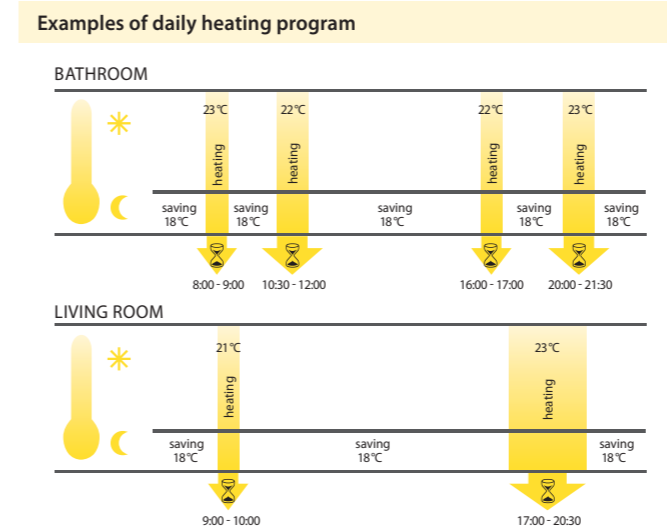

Adapters

Type of valve	Type of adapter
Heimeier, Junkers Landys+Gyr, MNG, Honeywell, Braukmann thread size M 30x1.5	No adapter necessary + enclosed pin; only for RAV
Danfoss RAV (the valve plunger must be fitted with the enclosed pin) Danfoss RA	
Danfoss RAVL	

- This energy-saving digital thermo-valve is a programmable regulation device for various heaters, but mainly radiators.
- It can be used to regulate temperature in closed rooms, thus helping to lower heat energy consumption.
- Functions:
 - Manual mode - measuring and checking a manually set temperature.
 - Automatic mode - control between two temperatures based on a set time program:
 - comfort temperature (factory settings 21 °C / 70 °F)
 - energy-saving temperature (factory settings 16 °C / 61 °F).
- Intervals of heating and energy-saving operation can be set using a freely adjustable time program.
 - 8 individually programmable switching times per day:
 - 4 heating intervals
 - 4 energy-saving intervals.
- The device features very quiet operation and long battery life (up to 5 years).
- Quick and easy installation.

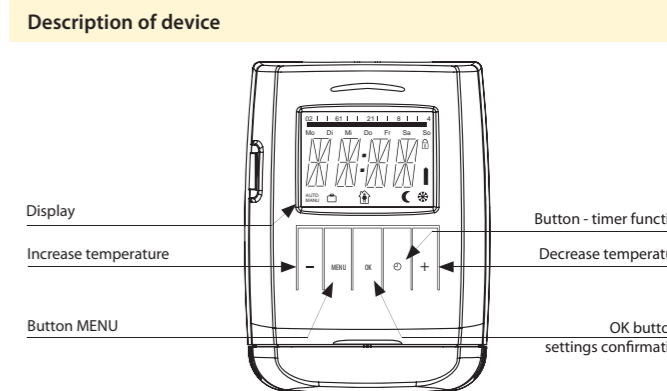

- Other functions**
1. Time function - the desired temperature can be set for a certain adjustable time interval.
 2. Vacation function - while you're gone, you can set and maintain the desired temperature.
 3. Open window function - when the temperature drops, the heating valve automatically closes in order to save energy.
 4. Child safety block - blocking against undesired interference with the thermostat.
 5. Freeze protection - if the temperature drops below 6 °C (43 °F), the valve opens until the temperature again exceeds 8 °C (46 °F). This keeps heaters from freezing.

Adjustment ATV-1

- manual
- via USB programming adapter PROGmatic

Using the programming port, in seconds your settings will be transferred into the thermostat.





- Two-level thermostat with function "WINDOW" meaning that output is switched in case the measured temperature is within set range (adjustable in range -20.. +20 °C / -4 °F to +68 °F).
- Used as protection against freezing (water-shoots, pavements, drives, pipes, etc.) heating is on when temperature falls under set upper level (e.g. +5 °C / +41 °F) and off in case it falls under lower level (e.g. -10 °C / -50 °F, when heating is not able effectively operate).
- Thermostat is placed in water-proof box with IP65, which allows installation outside, with in-built sensor TC-0.
- Thermostat status is indicated by LED (3 colors) under transparent cover.
- Function monitoring short-circuit and sensor disconnection (break).
- Output changeover contact 16 A / SPDT (AC-1).

EAN code
TEV-1: 8595188129121

Technical parameters		TEV-1
Function:	two-level thermostat	
Supply terminals:	L - N	
Voltage range:	230 V AC / 50 - 60 Hz	
Input:	max. 2.5 VA	
Tolerance of voltage range:	±15 %	
Measuring circuit		
Measuring terminals:	T - T	
Temperature ranges		
thermostat 1:	-20 to 20°C (-4 °F to 68 °F)	
thermostat 2:	-20 to 20°C (-4 °F to 68 °F)	
Hysteresis (sensitivity):	3°C (± 1.5 °C) / 37.4 °F (± 34.7 °F)	
Sensor:	thermistor NTC 12 kΩ / 25 °C (77 °F)	
Faulty sensor indication:	red LED flashing	
Accuracy		
Accuracy of settings (mech.):	5 %	
Dependence on temperature:	< 0.1 % / °C (°F)	
Output		
Number of contacts:	1x changeover / SPDT (AgNi / Silver Alloy)	
Current rating:	16 A / AC1	
Max. breaking capacity:	4000 VA / AC1, 384 W / DC	
Peak current:	30 A / < 3 s	
Switched voltage:	250 V AC1 / 24 V DC	
Min. switching output DC:	500 mW	
Output indication:	LED	
Mechanical life:	3x10 ⁷	
Electrical life:	0.7x10 ⁵	
Other information		
Operation temperature:	-30 °C to 50 °C (-22 °F to 140 °F)	
Operation position:	any	
Protection degree:	IP65	
Overvoltage category:	III.	
Pollution level:	2	
Max. cable size (mm ²):	solid wire 2.5 / with sleeve 1.5 (AWG 12)	
Dimensions:	110 x 135 x 66 mm (4.33" x 5.3" x 6.6")	
Weight:	238 g (8.4 oz.)	
Standards:	EN 60730-2-9, EN 61010-1	

Connection

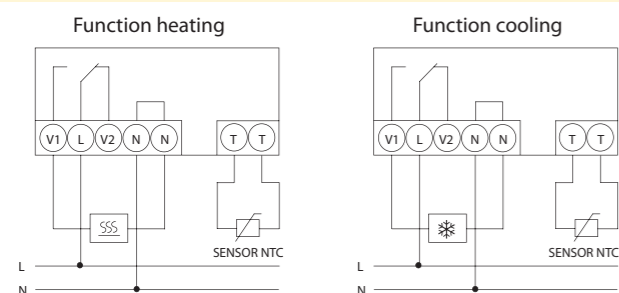

Description

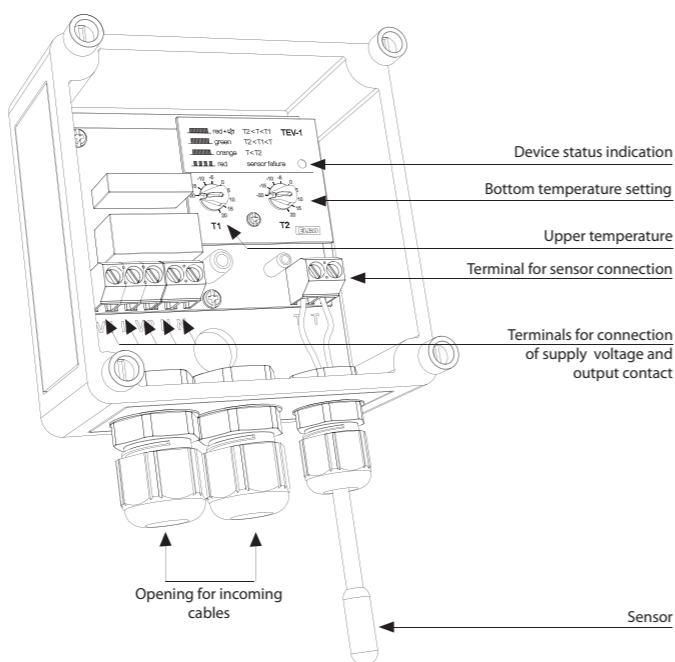

Function

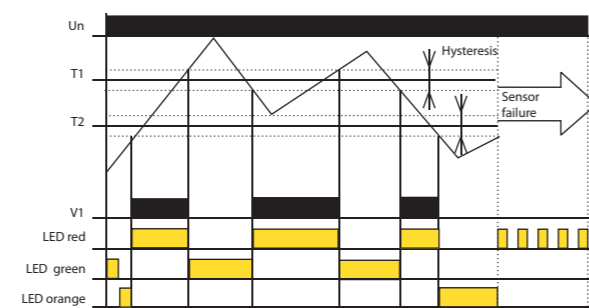

TEV-1 is a double thermostat designated for system of protection of roof water-shoots against freezing. The device is placed in a waterproof box (IP65), sensor with double insulation, which is a part of the device, senses ambient temperature. The device operates as zonal thermostat with independent setting of upper and bottom operational temperature. In case the ambient temperature is higher than T1 (upper temperature), thermostat switches heating of watershoots off (icing melts down). In case the ambient temperature is lower than T2 (bottom temperature), thermostat also switches heating off (to big freezing-heating cannot manage to melt the ice).

Symbol

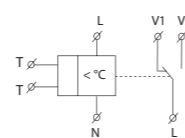

EAN code
TEV-2: 8595188129251
TEV-3: 8595188129268

Technical parameters		TEV-2	TEV-3
Function:	one-level thermostat		
Supply terminals:	L - N		
Voltage range:	230 V AC / 50 - 60 Hz		
Input:	max. 2.5 VA		
Tolerance of voltage range:	± 15 %		
Measuring circuit			
Measuring terminals:	T - T		
Temperature ranges:	-20 to 20°C (-4 to 68 °F)		5 to 35°C (41 to 95 °F)
Hysteresis (sensitivity):	3 °C (± 1.5 °C) / 37.4 °F (± 34.7 °F)		
Sensor:	thermistor NTC 12 kΩ		
Faulty sensor indication:	red LED flashing		
Accuracy			
Accuracy of settings (mech.):	5 %		
Dependence on temperature:	< 0.1 % / °C (°F)		
Output			
Number of contacts:	1x changeover / SPDT (AgNi / Silver Alloy)		
Current rating:	16 A / AC1		
Max. breaking capacity:	4000 VA / AC1, 384 W / DC		
Peak current:	30 A / < 3 s		
Switched voltage:	250 V AC1 / 24 V DC		
Min. switching output DC:	500 mW		
Output indication:	red LED		
Mechanical life:	3x10 ⁷		
Electrical life (AC1):	0.7x10 ⁵		
Other information			
Operation temperature:	-30 to 50 °C (-22 °F to 122 °F)		
Operation position:	any		
Protection degree:	IP65		
Overvoltage category:	III.		
Pollution level:	2		
Max. cable size (mm ²):	solid wire 2.5 / with sleeve 1.5 (AWG 12)		
Dimensions:	110 x 135 x 66 mm (4.33" x 5.3" x 2.3")		
Weight:	266 g (9.38 oz.)		277 g (9.77 oz.)
Standards:	EN 60730-2-9, EN 61010-1		

Connection

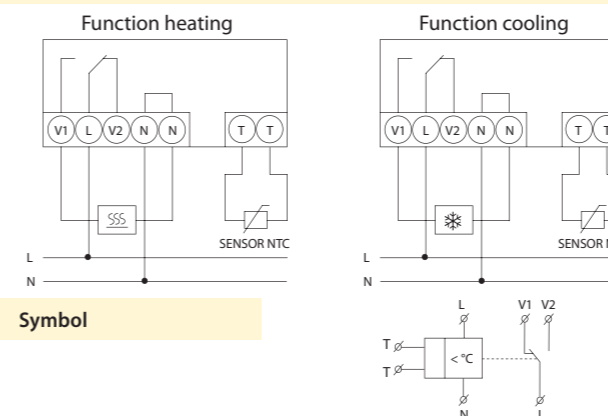

Symbol

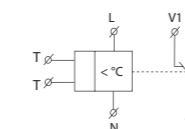

- Single thermostat with possibility of temperature management in adjustable range (it is possible to modify this range or make a special one on request).
- Used to regulate heating (or cooling) in demanding environments (outside, humidity, dustiness, etc.).
- Thermostat is placed in water-proof box with IP65 protection, which enables installation outside, with in-built sensor TC-0.
- TEV-2: control and indication elements are placed under transparent cover.
- TEV-3: control and indication elements are placed directly on the cover (for easy orientation and frequent change of temperature).
- Thermostat status is indicated by LED (2 colours).
- Function of monitoring sensor disconnection and short-circuit.
- Output changeover / SPDT contact 16 A (AC-1).

Description TEV-2 (without cover)

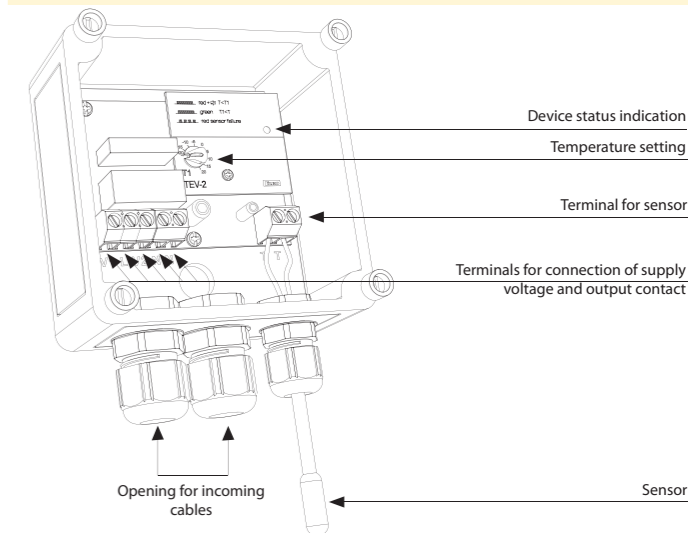

Description TEV-3 (cover)

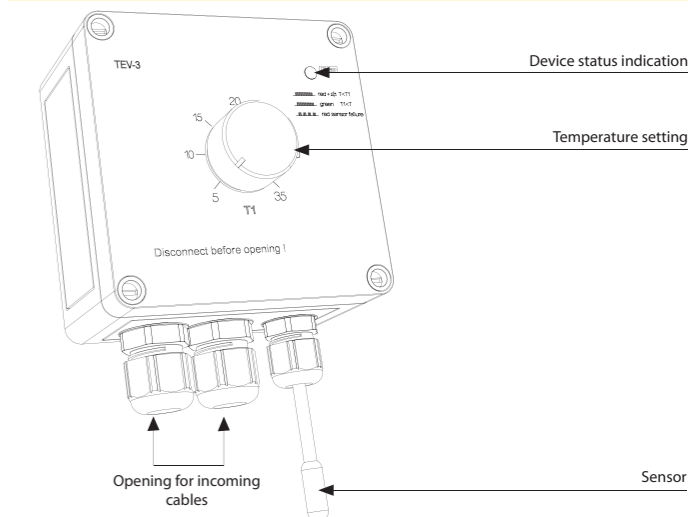

Function TEV-2, TEV-3

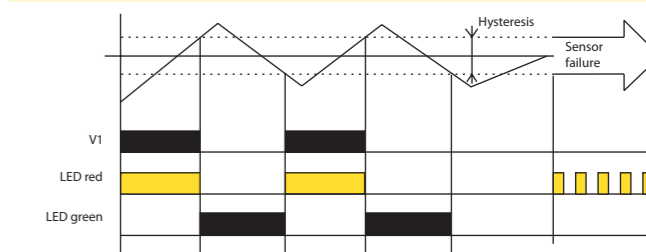

TEV-2 and TEV-3 are universal single thermostats for universal use. In case ambient temperature is higher than set temperature relay is open (function HEATING), for cooling function (opposite function) is possible to use NC contact of relay (V2).



EAN code
TEV-4: 8595188140577

Technical parameters		TEV-4
Supply		
Supply terminals:	L - N	
Voltage range:	AC 230V / 50 - 60Hz	
Tolerance of voltage range:	- 15% .. +10%	
Input (apparent / loss):	max. 6VA / 0.7W	
Function		
setting by jumper J3		
Function - ❄️:	cooling	
Function - 🔥:	heating	
Temperature setting		
by jumper J2		
- range 1:	-30 °C to 0 °C (-22 °F to 32 °F)	
- range 2:	0 °C to 30 °C (32 °F to 86 °F)	
- range 3:	30 °C to 60 °C (86 °F to 140 °F)	
Slight temperature setting:	potentiometer	
Hysteresis		
0.5 / 1.5 / 4 °C (32.9 / 34.7 / 39.2 °F)		
Hysteresis setting:	by jumper J1	
Output		
Output contact:	1 x NO-SPST (AgSnO ₂)	
Current rating:	12 A / AC1	
Max. breaking capacity:	3000 VA / AC1, 384 W / DC	
Peak current:	30 A / < 3 s	
Switched voltage:	250 V AC / 24 V DC	
Min. switching output:	500 mW	
Mechanical life:	3 x 10 ⁷	
Electrical life:	0.7 x 10 ⁵	
Other information		
Operation temperature:	-30 °C to 65 °C (-22 °F to 149 °F)	
Storing temperature:	-30 °C to 70 °C (-22 °F to 158 °F)	
Electrical strength:	4kV (supply-output)	
Operation position:	sensor-side down	
Protection degree:	IP65	
Overvoltage category:	III.	
Pollution degree:	2	
Max. cable size (mm ²):	max. 1x 2.5, max. 2x 1.5/ with sleeve max. 1x 2.5 (AWG 12)	
Suggested power-supply cable:	CYKY 3x2.5 (CYKY4x1.5)	
Dimensions:	153 x 62 x 34 mm (6" x 2.4" x 1")	
Weight:	148 g (5.2 oz.)	
Standards:	EN 60730-2-9, EN 61010-1	

Function

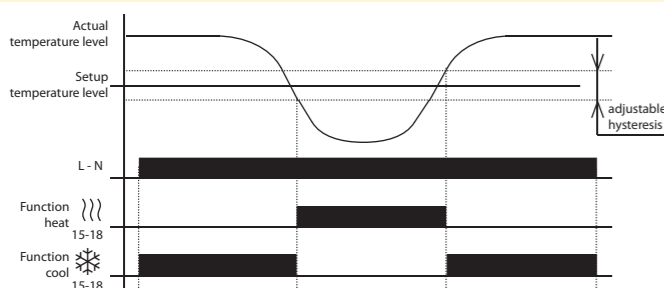

- Single point thermostat for monitoring and regulation of temperature in demanding environments (humid and contaminated, aggressive and defective, industrial workshops, washing rooms, green-houses, cellars and cooling boxes...).
- External version in IP65, box for mounting on the wall.
- Built-in thermo-sensor is integrated in the device.
- Two functions adjustable by jumper: heating and cooling.
- 3 adjustable (by jumper) ranges of temperature, and fine adjustment through potentiometer.
- 3 adjustable (by jumper) levels of hysteresis.
- Supply voltage 230 V AC.
- Potentialless NO-SPST contact 12 A AC1 switching.

Description

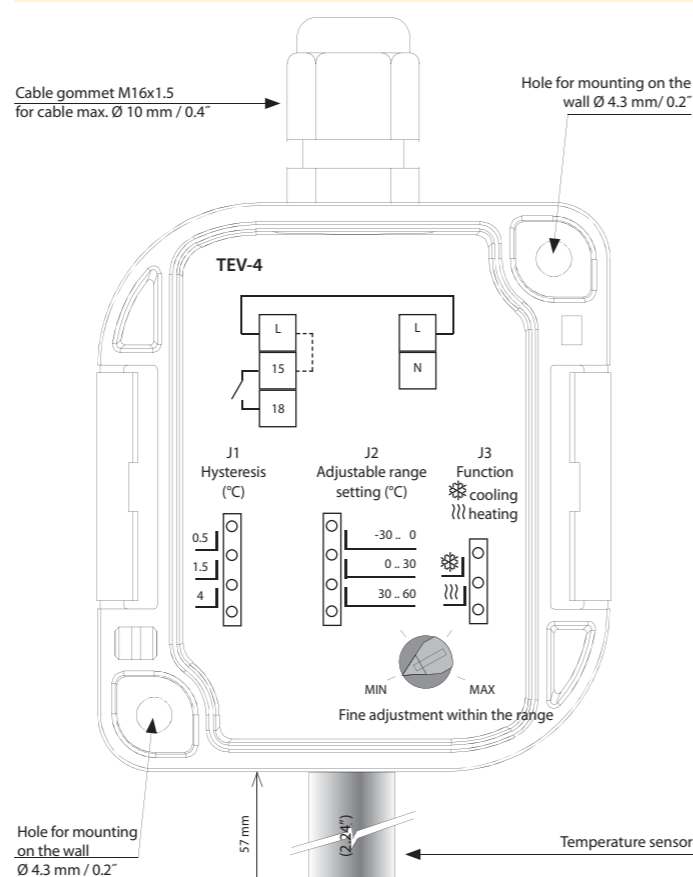

Connection

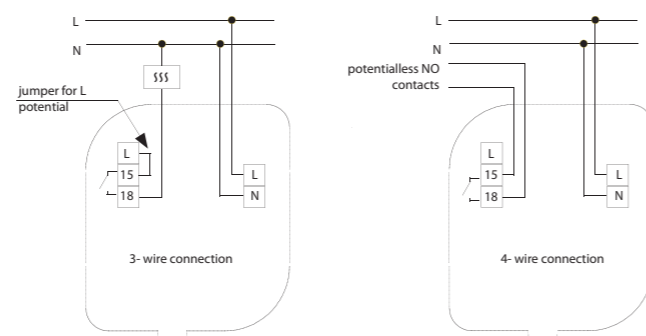

Description of function

Device is standardly supplied with jumper L-15 (3-wire connection). For the correct function of device is necessary sensor-side down device mounting.



EAN code
RHT-1: 8595188137263

Technical parameters		RHT-1
Function:		
hygro-thermostat		
Supply terminals:		
A1 - A2		
Input:		
1VA		
Voltage range:		
24-240V AC / DC (AC 50 - 60 Hz)		
Tolerance of voltage range:		
-15%; +10%		
Measuring circuit		
Temperature range:		
0 °C to 60 °C (32 °F to 140 °F)		
Humidity range:		
50.. 90%		
Temperature hysteresis:		
2.5 °C (4.5 °F)		
Humidity hysteresis:		
4%		
Sensor:		
internal		
Indication of sensor's fault:		
red LED flashing		
Accuracy		
Setting accuracy (mechanical):		
5%		
Long-term stability of humidity:		
typical < 0.8% / year		
Output		
Number of contacts:		
1x NO-SPST (AgSnO ₂)		
Current rating:		
16A / AC1, 10A / 24V DC		
Switched output:		
4000 VA / AC1, 300W / DC		
Switched voltage:		
250V AC1 / 24V DC		
Output indication:		
red LED shines		
Mechanical life:		
3x10 ⁷		
Electrical life:		
0.7x10 ⁵		
Other information		
Operational temperature:		
-20 °C to 60 °C (-4 °F to 140 °F)		
Storing temperature:		
-30 °C to 70 °C (-22 °F to 158 °F)		
Electrical strength:		
2.5 kV (supply-output)		
Operational position:		
vertical, with correct orientation		
Mounting:		
DIN rail EN 60715		
Protection degree:		
IP40 from front panel, IP10 on terminals		
Overvoltage category:		
III.		
Pollution degree:		
2		
Max. cable size (mm²):		
max. 2x 2.5, max. 1x 4 with sleeve max. 1x 2.5, max. 2x 1.5 (AWG 12)		
Dimensions:		
90 x 17.6 x 64 mm (3.5" x 0.7" x 2.5")		
Weight:		
69 g (2.4 oz.)		
Standards:		
EN 60730-2-9, EN 61010-1		

- Hygro-thermostat for temperature monitoring and regulation in range 0 °C to 60 °C (32 °F to 140 °F) and relative humidity monitoring and regulation in range 50..90%.
- Possibility of setting of up to 8 conditions for contact switching and function permanently ON/OFF.
- Sensor is a part of the device - designated for measuring in switchboards.
- Function of sensor control (damage, disturbances...).
- Fixed setting of temperature hysteresis at 2.5 °C (4.5 °F) and humidity at 4%.
- Output state is indicated by red LED.
- Supply voltage AC/DC 24-240 V.
- Output contact 1x NO-SPST 16A/250 V AC1.
- 1-MODULE, DIN rail mounting.

Device description

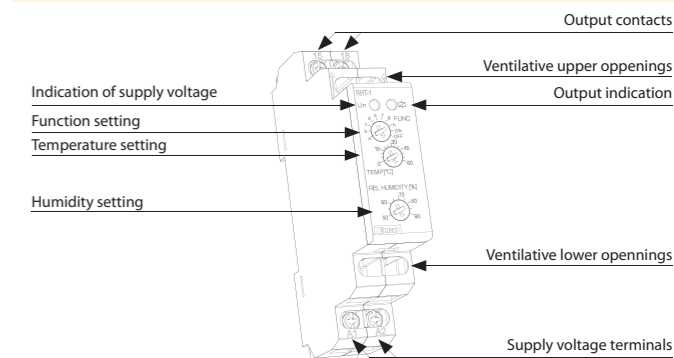

Funcions

Choice of function Relay switched under the following conditions

Choice of function	Relay switched under the following conditions
A	T > Tset or RH > RHset
B	T < Tset or RH > RHset
C	T > Tset or RH < RHset
D	T < Tset or RH < RHset
E	T < Tset a RH < RHset
F	T > Tset a RH < RHset
G	T < Tset a RH > RHset
H	T > Tset a RH > RHset
ON	relay permanently ON
OFF	relay permanently OFF

This device is designated for monitoring of parameters of environment (meaning temperature and relative humidity) in switchboards. It enables setting of eight conditions of contact closing and therefore it is usable for various types of load (e.g. fans, heating, air-conditioning, dehydrating units...).

While installing it is necessary to take into account the fact that hysteresis rises by persistence of measured values between sensor and ambient environment.

The device is equipped by sensor fault detection. In case of sensor fault, exceeding allowed limits (for temperature -30°C/ -22 °F and +80°C/ 176 °F; for humidity 5% and 95%) or in case of faulty internal communication higher than 50% (due to e.g. high ambient disturbances) contact opens and sensor fault is indicated. Sensor fault doesn't have influence on function permanently ON or permanently OFF.

Note: In case the conditions for switching are not applied, relay is open.

Symbol

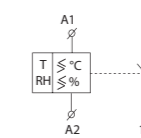

Connection





EAN code
RHV-1: 8595188140584

Technical parameters		RHV-1
Supply		
Supply terminals:	L - N	
Voltage range:	AC 230V / 50 - 60Hz	
Input voltage range:	- 15% .. +10%	
Input (apparent/loss):	max. 6VA / 0.7W	
Setting function		
Setting function Jumper J3		
Function -	moistening	
Function -	drying	
Set. the scale of relative humidity		
Humidity setting Jumper J2		
- range 1:	0 ... 30 % RH	
- range 2:	30 ... 60 % RH	
- range 3:	60 ... 90 % RH	
Slight setting of relative humidity:	Relative Humidity Setting Potentiometer	
Hysteresis		
2, 3, 4 % from setup rate		
Hysteresis setting:	Jumper J1	
Output		
Output contact:	1x NO-SPST (AgSnO ₂)	
Current rating:	12 A / AC1	
Switching output:	3000 VA / AC1, 384 W / DC	
Peak current:	30 A / < 3 s	
Switched voltage:	250 V AC / 24 V DC	
Min. switching output:	500 mW	
Mechanical life:	3 x 10 ⁷	
Electrical life:	0.7 x 10 ⁵	
Other information		
Operation temperature:	-30 °C to 60 °C (-22 °F to 140 °F)	
Storing temperature:	-30 °C to 70 °C (-22 °F to 158 °F)	
Electrical strength:	4kV (supply-output)	
Operation position:	sensor-side down	
Protection degree:	IP65	
Overvoltage category:	III.	
Pollution degree:	2	
Max. cable size (mm ²):	max. 1x2.5, max. 2x1.5/ with sleeve max. 1x2.5 (AWG 12)	
Suggested power-supply cable:	CYKY 3x2.5 (CYKY4x1.5)	
Dimensions:	153 x 62 x 34 mm (6" x 2.4" x 1.3")	
Weight:	148 g (5.2 oz.)	
Standards:	EN 60730-2-9, EN 61010-1	

Function

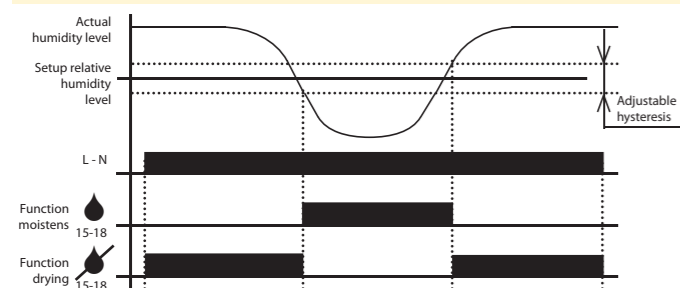

- Single hygrostat is used for regulation of humidity in harsh environments (washdown, greenhouse, refrigeration).
- External version in IP65, box for mounting on the wall.
- Built-in hygro-sensor is integrated in the device.
- Two functions adjustable by jumper: moistening and drying.
- 3 adjustable (by jumper) levels of hysteresis.
- Supply voltage 230V AC.
- NO contact closure 12A/AC1.

Description

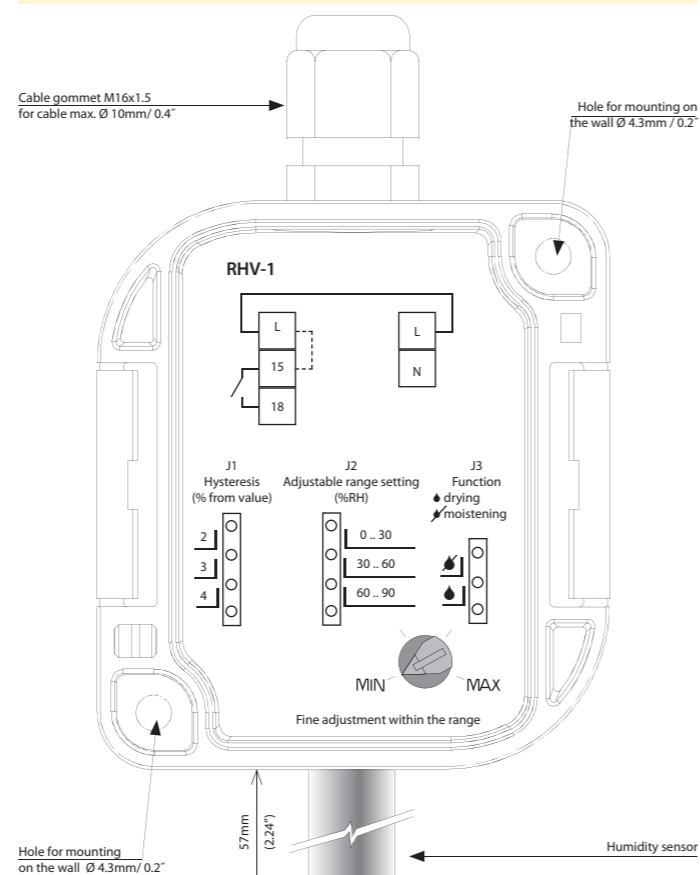

Connection

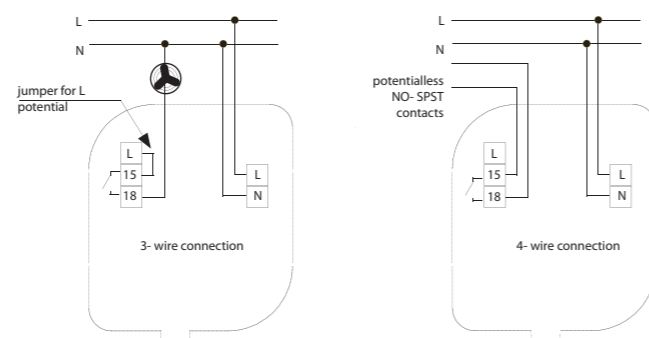

Description of function

Device is supplied with a standard jumper.
For the device to operate correctly, it must be mounted with the sensor side down.

Accessories

TC, TZ, Pt100 | Thermo sensors



EAN code	TC-0:	TZ-0:	Pt100-3:
TC-0:	8595188110075	8595188140591	8595188136136
TC-3:	8595188110617	8595188110600	8595188136143
TC-6:	8595188110082	8595188110594	8595188136150
TC-12:	8595188110099	8595188110587	

Technical parameters	TC	TZ	Pt100
Range:	0 °C to +70 °C (32 °F to 158 °F)	-40 °C to +125 °C (-40 °F to 257 °F)	-30 °C to +200 °C (-22 °F to 392 °F)
Scanning element:	NTC 12K 5 %	NTC 12K 5 %	Pt100
In air/ in water:	(τ65) 92 s / 23 s	(τ65) 62 s / 8 s	(τ0.5) - / 7 s
In air/ in water:	(τ95) 306 s / 56 s	(τ95) 216 s / 23 s	(τ0.9) - / 19 s
Cable material:	High temperature PVC	Silicone copper	Silicone Copper
Terminal material:	High temperature PVC	Nickel plated copper	Copper
Protection degree:	IP 67	IP 67	IP 67
Insulation:	-	-	double insulation silicone

Types of temperature sensors:

- length:	TC-0	TZ-0	-
- weight:	100 mm	110 mm	-
- length:	TC-3	TZ-3	Pt100-3
- weight:	5 g	4.5 g	3 m
- length:	108 g	106 g	68 g
- length:	TC-6	TZ-6	Pt100-6
- weight:	6 m	6 m	6 m
- length:	213 g	216 g	149 g
- length:	TC-12	TZ-12	Pt100-12
- weight:	12 m	12 m	12 m
- length:	466 g	418 g	249 g

τ65 (95): time, which sensor needs to heat up on 65 (95) % of ambient temperature of environment, in which is located.

- Thermister temperature sensors are made of Negative Temperature Coefficient (NTC) embedded in a PVC or metal sleeve with a thermally-conductive sealer.

• Sensor TC

- lead-in cable to sensor TC is made of wire CYSY 2D x 0.5 mm/ 0.02".

• Sensor TZ

- cable VO3SS-F 2D x 0.5 mm /0.02" with silicone insulation for use in high temperature applications.

- silicone insulation for use in high temperature applications.

• Sensor Pt100

- shielded silicon 2x 0.22 mm² (AWG 21), shielding connected with a case.

Resistive values of sensors in dependance on temperature

Temperature (°C/°F)	Sensor NTC (kΩ)	Sensor Pt100 (Ω)
20 / 68	14.7	107.8
30 / 86	9.8	111.7
40 / 104	6.6	115.5
50 / 122	4.6	119.4
60 / 140	3.2	123.2
70 / 158	2.3	127.1

Tolerance of sensor NTC 12 kΩ is ± 5% by 25 °C/ 77°F.

Long-term resistance stability by sensor Pt100 is 0.05% (10 000 hours)

Diagramm of sensor warm up via air

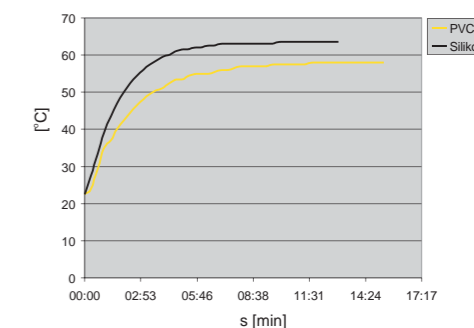

PVC -reaction to water temperature from 22.5 °C to 58 °C (from 72.5 °F to 136.4 °F).

Silicone - reaction to water temperature from 22.5 °C to 63.5 °C (from 72.5 °F to 144.5 °F).

TELVA 230V, TELVA 24V | Termodrive



EAN code
 TELVA 230V, NC: 8595188166010
 TELVA 230V, NO: 8595188166027
 TELVA 24V, NC: 8595188166034
 TELVA 24V, NO: 8595188166041

Technical parameters	TELVA 230V	TELVA 24V
Operating voltage:	230V, 50/60 Hz	24V, 50/60 Hz
Switching current max:	300 mA for max. 2 min	250 mA for max. 2 min
Operating current:	8 mA	75 mA
Closing / opening time:	cca 3 min.	cca 3 min.
Power input:	1.8 W	1.8 W
Protection:	IP 54/II	IP 54/II
Settings:	4 mm	4 mm
Stopping force:	100 N ±5 %	100 N ±5 %
Cable length:	1 m	1 m
Connecting wire:	2 x 0.75 mm ²	2 x 0.75 mm ²
Media temperature:	0.. +100 °C	0.. +100 °C
Color:	white RAL 9003	white RAL 9003
Dimensions h/w/d:	55+5 x 44 x 61 mm	55+5 x 44 x 61 mm

- The thermo-regulation drive TELVA is used to control underfloor and radiator hot-water heating.
- It is known for its quiet operation. It has a built-in valve position indicator.
- By mounting using the VA valve adapter, the thermo-regulation drive TELVA is applicable for a wide range of thermostatic valves available on the market.
- Design:
 - without voltage open (NO)
 - without voltage closed (NC)
- Types of thermo actuators:
 - TELVA 230V, NO
 - TELVA 230V, NC
 - TELVA 24V, NO
 - TELVA 24V, NC

- Type of use:
 Underfloor heating - wireless controller RFTC-50/G measures the room temperature, and based on the set program, sends a command to the switching unit RFSA-66M to open / close the thermo-regulation drive TELVA at the distribution.rozdělovači.

It is generally supplied with a valve adapter VA-80 in low design with bar M30 x 1.5 (white-gray), which may not be compatible with all types of valves.

LKM-45 | Installation box



EAN code
 LKM-45: 8595188130806

- recommended installation boxes for mounting Thermo thermostats to the wall
- dimensions: 98 x 98 x 45 mm (3.85 x 3.85 x 1.77")
- color: white

Usage



Installation contactors VS

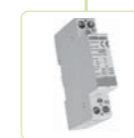

VS120
 Number of contacts:
 1x20 A
 Configuration of
 switching and breaking
 contacts: 10, 01.



VS220
 Number of contacts:
 2x20 A
 Configuration of
 switching and breaking
 contacts: 20, 11, 02.



VS420
 Number of contacts:
 4x20 A
 Configuration of
 switching and breaking
 contacts: 40, 31.



VS425
 Number of contacts:
 4x25 A
 Configuration of
 switching and breaking
 contacts:
 40, 31, 22, 04.



VS440
 Number of contacts:
 4x40 A
 Configuration of
 switching and breaking
 contacts:
 40, 31, 22, 04.



VS463
 Number of contacts:
 4x63 A
 Configuration of
 switching and breaking
 contacts:
 40, 31, 22.

Installation contactors with manual control VSM



VSM220
 Number of contacts:
 2x20 A
 Configuration of
 switching and breaking
 contacts: 20, 11, 02.

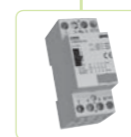

VSM425
 Number of contacts:
 4x25 A
 Configuration of
 switching and breaking
 contacts:
 40, 31, 22, 04.

Accessories



VSK-11
 Auxiliary contacts:
 1x switching,
 1x breaking.



VSK-20
 Auxiliary contacts:
 2x switching.

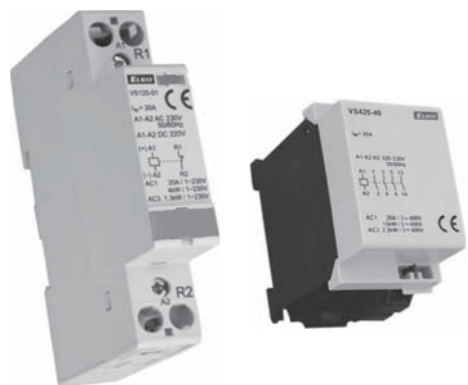

- For switching electric circuits, especially for resistive loads and three-phase induction motors:
 - number of contacts VS120: 1
 - number of contacts VS220: 2
 - number of contacts VS420, VS425, VS440, VS463: 4
- It is produced in configuration of switching and breaking contacts:
 - VS120: 10, 01
 - VS220: 20, 11, 02
 - VS420: 40, 31
 - VS425: 40, 31, 22, 04
 - VS440: 40, 31, 22, 04
 - VS463: 40, 31, 22
- Protection IP20 - on request we deliver covers that ensure protection IP40 for all terminals.
- DIN rail or panel mounting.

EAN code see page 120

Technical parameters	VS120	VS220	VS420	VS425	VS440	VS463
Rated insulation voltage (Ui):	230 V	230 V	415 V	440 V	440 V	440 V
Rated thermo-current I _m (in AC):	20 A	20 A	20 A	25 A	40 A	63 A
Switched operation						
AC-1 for 400 V, 3 phase:	x	x	13 kW	16 kW	26 kW	40 kW
AC-1 for 230 V:	4 kW, 1 phase	4 kW, 1 phase	7.5 kW, 3 phase	9 kW, 3 phase	16 kW, 3 phase	24 kW, 3 phase
AC-3 for 400 V, 3 phase:	x	x	2,2 kW	4 kW	11 kW	15 kW
AC-3 for 230 V:	1.3 kW only NO, 1 phase	1.3 kW only NO, 1 phase	1.1 kW, 3 phase	2.2 kW, 3 phase	5.5 kW, 3 phase	8.5 kW, 3 phase
AC-7a for 400 V, 3 phase:	x	x	13 kW	16 kW	26 kW	40 kW
AC-7a for 230 V:	4 kW, 1 phase	4 kW, 1 phase	7.5 kW, 3 phase	9 kW, 3 phase	16 kW, 3 phase	24 kW, 3 phase
AC-7b for 400 V, 3 phase:	x	x	2,2 kW	4 kW	11 kW	15 kW
AC-7b for 230 V:	1.3 kW only NO, 1 phase	1.3 kW only NO, 1 phase	1.1 kW, 3 phase	2.2 kW, 3 phase	5.5 kW, 3 phase	8.5 kW, 3 phase
AC-15 for 400 V, 1 phase:	4 A	4 A	4 A	4 A	4 A	4 A
AC-15 for 230 V, 1 phase:	6 A	6 A	6 A	6 A	6 A	6 A
DC1 U _e = 24 V:	20 A	20 A	20 A	25 A	40 A	63 A
DC1 U _e = 110 V:	6 A	6 A	2 A	6 A	4 A	4 A
DC1 U _e = 220 V:	0.6 A	0.6 A	0.5 A	0.6 A	1.2 A	1.2 A

Loadability of modular contactors see page 119

The max. number of switching for max. load:	600 switch/hr.	600switch/hr.	600 switch/hr.	600 switch/hr.	600 switch/hr.	600 switch/hr.
---	----------------	---------------	----------------	----------------	----------------	----------------

Electrical life in 230 / 400 V						
AC-1-resistive load :	0.2x10 ⁶	0.2x10 ⁶	0.2x10 ⁶	0.2x10 ⁶	0.1x10 ⁶	0.1x10 ⁶
AC-3-power load:	0.3x10 ⁶	0.3x10 ⁶	0.3x10 ⁶	0.5x10 ⁶	0.15x10 ⁶	0.15x10 ⁶
AC-5a - high-intensity discharge lamp:	0.1x10 ⁶ by 30 μF	0.1x10 ⁶ by 30 μF	0.3x10 ⁶ by 36 μF	0.1x10 ⁶ by 36 μF	0.1x10 ⁶ by 220 μF	0.1x10 ⁶ by 330 μF
AC-5b - incandescent lamps :	0.1x10 ⁶ by 2 kW	0.1x10 ⁶ by 2 kW	0.1x10 ⁶ by 2 kW	0.1x10 ⁶ by 2 kW	0.1x10 ⁶ by 4 kW	0.1x10 ⁶ by 5 kW
AC-7a - resistive household devices:	0.2x10 ⁶	0.2x10 ⁶	0.2x10 ⁶	0.2x10 ⁶	0.1x10 ⁶	0.1x10 ⁶
AC-7b - inductive household devices:	0.3x10 ⁶	0.3x10 ⁶	0.3x10 ⁶	0.3x10 ⁶	0.15x10 ⁶	0.15x10 ⁶
Minimal load:	≥ 17 V, ≥ 50 mA	≥ 17 V, ≥ 50 mA	≥ 17 V, ≥ 50 mA	≥ 17 V, ≥ 50 mA	≥ 17 V, ≥ 50 mA	≥ 24 V, ≥ 100 mA
Short circuit protection with the fuse char. aM:	20 A	20 A	20 A	25 A	63 A	80 A
Coordination Type according EN 60 947-4-1:	2	2	2	2	2	2
Electrical strenght:	4 kV	4 kV	4 kV	4 kV	4 kV	4 kV

Contacts - max. cable size						
Solid conductor:	AWG 7 (10 mm ²)	AWG 7 (10 mm ²)	AWG 10 (2.5 mm ²)	AWG 7 (10 mm ²)	AWG 3 (25 mm ²)	AWG 3 (25 mm ²)
Stranded conductor:	6 mm ²	6 mm ²	2.5 mm ²	6 mm ²	16 mm ²	16 mm ²
Maximal torque:	1.2 Nm	1.2 Nm	1.2 Nm	1.2 Nm	3.5 Nm	3.5 Nm

Coil - max. cable size						
Solid conductor:	AWG 10 (2.5 mm ²)	AWG 10 (2.5 mm ²)	AWG 10 (2.5 mm ²)	AWG 10 (2.5 mm ²)	AWG 10 (2.5 mm ²)	AWG 10 (2.5 mm ²)
Stranded conductor:	2.5 mm ²	2.5 mm ²	2.5 mm ²	2.5 mm ²	2.5 mm ²	2.5 mm ²
Max. torque:	0.6 Nm	0.6 Nm	0.6 Nm	0.6 Nm	0.6 Nm	0.6 Nm

Operating						
Coil control voltage:	AC/DC 24 V, 230 V	AC/DC 24 V, 48 V, 110 V, 230 V	AC 12 V, 24 V, 48 V, 110 V, 230 V	AC/DC 24 V, 48 V, 110 V, 230 V	AC/DC 24 V, 110 V, 230 V	AC/DC 24 V, 110 V, 230 V
Coil permanent supply +/- 10 %:	2.1 VA/2.1 W	2.1 VA/2.1 W	5 VA/1.5 W	2.6 VA/2.6 W *	5 VA/5 W	5 VA/5 W
Coil gear supply +/- 10 %:	2.1 VA/2.1 W	2.1 VA/2.1 W	30 VA/25 W	2.6 VA/2.6 W *	5 VA/5 W	5 VA/5 W
Mounting side-by-side:	max. 2 contactors**	max. 2 contactors**	max. 2 contactors**	max. 2 contactors**	max. 2 contactors**	max. 2 contactors**
Operational temperature:	-5 ... +55 °C (23.. 131 °F)					
Storing temperature:	-30... +80 °C (-22.. 176 °F)					
Weight:	120 g (4.2 oz.)	130 g (4.6 oz.)	170 g (6 oz.)	213 g (7.5 oz.)	400 g (14 oz.)	400 g (14 oz.)
Dimensions:	17.5 x 85 x 60 mm (0.7"x 3.35"x 2.4")	17.5 x 85 x 60 mm (0.7"x 3.35"x 2.4")	35 x 62.5 x 57 mm (1.4"x 2.7"x 2.24")	35 x 85 x 60 mm (1.4"x 3.35"x 2.4")	53.3 x 84 x 60 mm (2.1"x 3.31"x 2.4")	53.3 x 84 x 60 mm (2.1"x 3.31"x 2.4")
Standards:	IEC 60947-4-1, IEC 60947-5-1, IEC 61095, EN 60947-4-1, EN 60947-5-1, EN 61095, VDE 0660					

* 3.8 VA/3.8 W for -04 version of contacts

** Note: In case several contactors are mounted close to each other, you need to use an installation spacer between every other contactor.

VS120



VS220

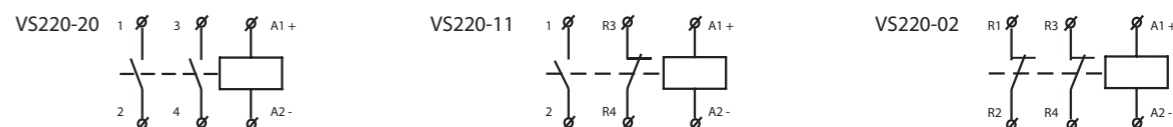

VS420

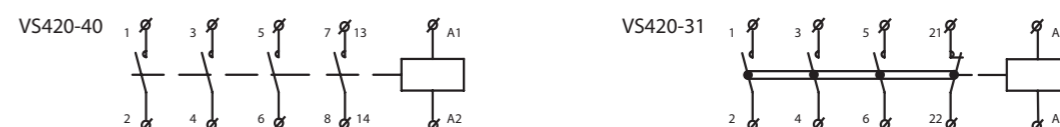

VS425

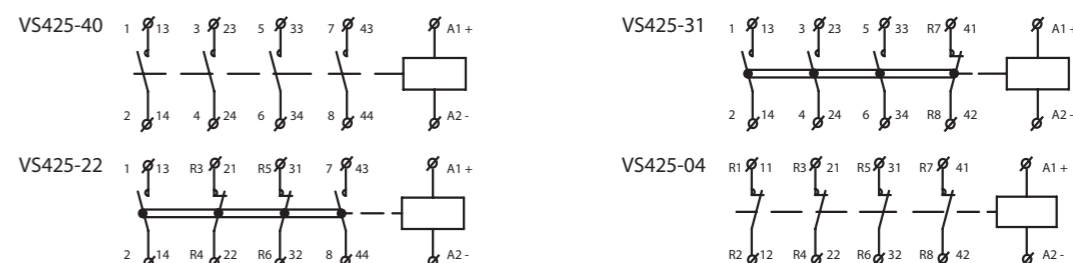

VS440

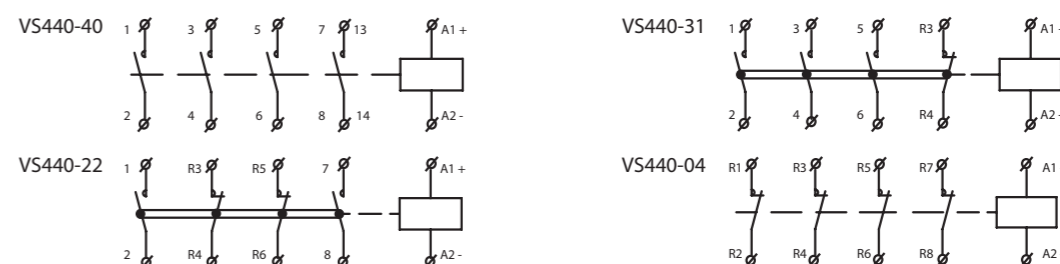

VS463

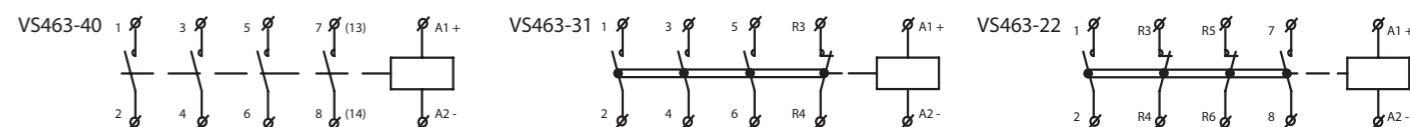

Auxiliary contacts for VS425, VS440, VS463 and VSM220, VSM425

Datas of auxiliary contacts for VSK-11 and VSK-20

Ambient temperature:	-5 °C to +55 °C (23 °F to 131 °F)
Rated insulation voltage (Ui):	500 V
Electrical strength:	4 kV
Rated current 230 V (AC 15):	6 A
Rated current 400 V (AC 15):	4 A
Max. switching frequency:	6 A
The max. number of switching for max. load:	600 sep./hod.
Minimal load:	≥ 12 V, ≥ 10 mA
Short circuit protection with the fuse char. aM:	6 A
Solid/ Stranded conductor (max):	2.5 mm ² / 2.5 mm ² (AWG 10)
Maximal torque:	0.8 Nm
Weight:	10 g (0.35 oz.)
Dimensions:	10 x 85 x 60 mm (0.4"x 3.35"x 2.4")

Connection of auxiliary contact VSK-11 and VSK-20

EAN code see page 120

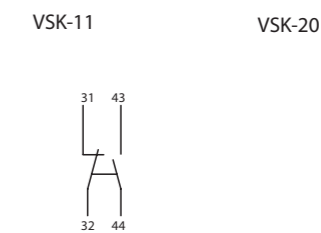

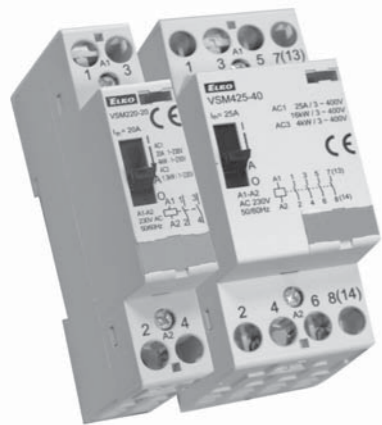

EAN code see page 120

Technical parameters	VSM220	VSM425
Rated insulation voltage (Ui):	230 V	440 V
Rated thermo-current I _{th} (in AC):	20 A	25 A
Switched operation		
AC-1 for 400 V:	x	16 kW, 3 phase
AC-1 for 230 V:	4 kW, 1 phase	9 kW, 3 phase
AC-3 for 400 V:	x	4 kW, 3 phase
AC-3 for 230 V:	1.3 kW only NO, 1 phase	2.2 kW, 3 phase
AC-7a for 400 V:	x	16 kW, 3 phase
AC-7a for 230 V:	4 kW, 1 phase	9 kW, 3 phase
AC-7b for 400 V:	x	4 kW, 3 phase
AC-7b for 230 V:	1.3 kW only NO, 1 phase	2.2 kW, 3 phase
AC-15 for 400 V:	4 A	4 A
AC-15 for 230 V:	6 A	6 A
DC1 U _e = 24 V:	20 A	25 A
DC1 U _e = 110 V:	6 A	6 A
DC1 U _e = 220 V:	0.6 A	0.6 A
Loadability of modular contactors see page 119		
The max. number of switching for max. load:	600 switch/hr.	600 switch/hr.
Electrical life in 230 / 400 V		
AC-1-resistive load :	0.2x10 ⁶	0.2x10 ⁶
AC-3-power load:	0.3x10 ⁶	0.5x10 ⁶
AC-5a - high-intensity discharge lamp:	0.1x10 ⁶ by 30 μF	0.1x10 ⁶ by 36 μF
AC-5b - incandescent lamps :	0.1 10 ⁶ by 1.5 kW	0.1x10 ⁶ by 1.5 kW
AC-7a - resistive household devices:	0.2x10 ⁶	0.2x10 ⁶
AC-7b - inductive household devices:	0.3x10 ⁶	0.5x10 ⁶
Minimal load:	≥ 17 V, ≥ 50 mA	≥ 17 V, ≥ 50 mA
Short circuit protection with the fuse char. aM:	20 A	25 A
Coordination Type according EN 60 947-4-1:	2	2
Electrical strenght:	4 kV	4 kV
Contacts - max. cable size		
Solid conductor:	AWG 7 (10 mm ²)	AWG 7 (10 mm ²)
Stranded conductor:	6 mm ²	6 mm ²
Maximal torque:	1.2 Nm	1.2 Nm
Coil - max. cable size		
Solid conductor:	AWG 10 (2.5 mm ²)	AWG 10 (2.5 mm ²)
Stranded conductor:	2.5 mm ²	2.5 mm ²
Max. torque:	0.6 Nm	0.6 Nm
Operating		
Coil control voltage:	AC 12 V, 24 V, 110 V, 230 V	AC 12 V, 24 V, 42 V, 230 V
Coil permanent supply +/- 10 %:	2.8 VA/1.2 W	5.5 VA/1.6 W
Coil gear supply +/- 10 %:	12 VA /10 W	33 VA/25 W
Mounting side-by-side:	max. 2 contactors*	max. 2 contactors*
Operational temperature:	-5 ... +55 °C (23.. 131 °F)	
Storing temperature:	-30... +80 °C (-22.. 176 °F)	
Weight:	140 g (4.9 oz.)	260 g (9.17 oz.)
Dimensions:	17.5 x 85 x 60 mm (0.7 x 3.35 x 2.4")	35 x 85 x 60 mm (1.4 x 3.35 x 2.4")
Standards:	IEC 60947-4-1, IEC 60947-5-1, IEC 61095, EN 60947-4-1, EN 61095, VDE 0660	

- Special version of installation contactors with not only basic functions but also with manual control.
- For switching accumulative appliances for heating and service water warming.
- Description of individual positions of manual control.
 - AUTO: common function as with installation contactors without manual control.
 - 1: shifting from AUTO to 1: operational contacts are closed and back contacts are open until there is another impulse to a contactor coil.
 - 0: contacts are open (operational contact) or closed (stand-by contact) regardless voltage.
- Optical indicator: ON-OFF.
- It is produced in configuration of making and breaking contacts:
 - VSM220: 20, 11, 02
 - VSM425: 40, 31, 22, 04
- It is possible to connect auxiliary contacts VSK to contactors VSM220, VSM425.

Connection VSM220 VSM220 - only AC supply voltage

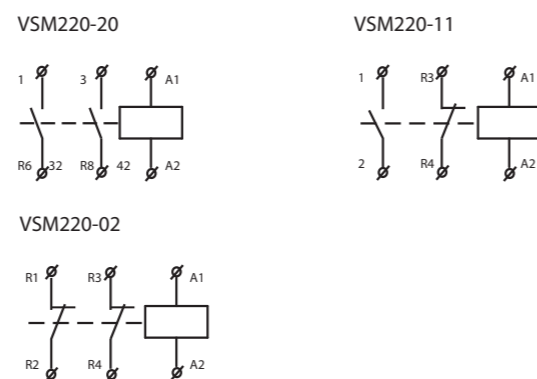

Connection VSM425 VSM425 - only AC supply voltage

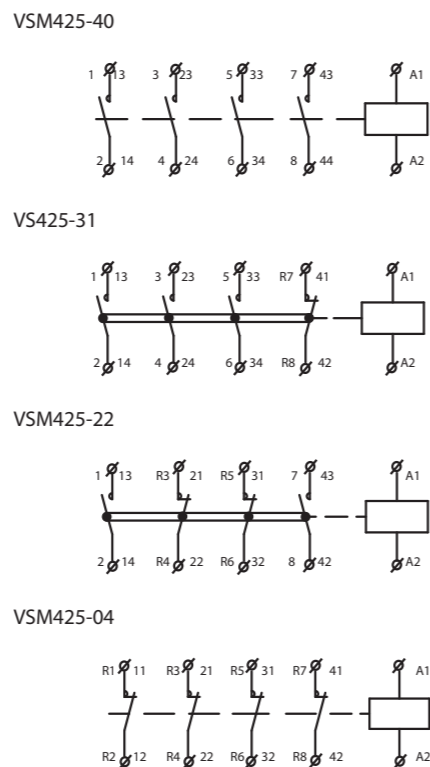

Auxiliary contacts VSK-11 and VSK-20

Datas of auxiliary contacts for VSK-11 and VSK-20 see page 117

TYPE OF LIGHT	OPERATION (W)	I (A)	Number of lights on one contactor's contact							
			VS120	VS220	VS420	VS425	VS440	VS463	VSM220	VSM425
Incandescent lamps	60	0.26	33	33	33	33	65	85	33	33
	100	0.43	20	20	20	20	40	50	20	20
	200	0.87	10	10	10	10	20	25	10	10
	500	2.17	3	3	3	3	8	10	3	3
	1000	4.35	1	1	1	1	4	5	1	1
Flourescent lamps	18	0.37	22	22	22	24	90	140	22	24
	24	0.35	22	22	22	24	90	140	22	24
	36	0.43	17	17	17	20	65	95	17	20
	58	0.67	14	14	14	17	45	70	14	17
	Flourescent lamps lead-lag circuit	18	0.11	2 x 30	2 x 30	2 x 30	2 x 40	2 x 100	2 x 150	2 x 30
	24	0.14	2 x 24	2 x 24	2 x 24	2 x 31	2 x 78	2 x 118	2 x 24	2 x 31
	36	0.22	2 x 17	2 x 17	2 x 17	2 x 24	2 x 65	2 x 95	2 x 17	2 x 24
	58	0.35	2 x 10	2 x 10	2 x 10	2 x 14	2 x 40	2 x 60	2 x 10	2 x 14
Flourescent lamps parallel correction	18	0.12	7	7	7	8	48	73	7	8
	24	0.15	7	7	7	8	48	73	7	8
	36	0.2	7	7	7	8	48	73	7	8
	58	0.32	4	4	4	5	31	47	4	5
	Flourescent lamps with electronic ballast units (EVG)	1 x 18	0.09	25	25	25	35	100	140	25
	1 x 36	0.16	15	15	15	20	52	75	15	20
	1 x 58	0.25	14	14	14	19	50	72	14	19
	2 x 18	0.17	12	12	12	17	50	70	12	17
	2 x 36	0.32	7	7	7	10	26	38	7	10
	2 x 58	0.49	7	7	7	9	25	36	7	9
High-pressure mercury-vapour lamps uncorrected	50	0.61	14	14	14	18	38	55	14	18
	80	0.8	10	10	10	13	29	42	10	13
	125	1.15	7	7	7	9	20	29	7	9
	250	2.15	4	4	4	5	10	15	4	5
	400	3.25	2	2	2	3	7	10	2	3
700	5.4	1	1	1	2	4	6	1	2	
1000	7.5	1	1	1	1	3	4	1	1	
High-pressure mercury-vapour lamps parallel correction	50	0.28	4	4	4	5	31	47	4	5
	80	0.41	4	4	4	5	27	41	4	5
	125	0.65	3	3	3	4	22	33	3	4
	250	1.22	1	1	1	2	12	18	1	2
	400	1.95	1	1	1	1	9	13	1	1
700	3.45	-	-	-	-	5	7	-	-	
1000	4.8	-	-	-	-	4	5	-	-	
Halogen metal vapour lamps uncorrected	35	0.53	18	18	18	22	43	60	18	22
	70	1	10	10	10	12	23	32	10	12
	150	1.8	5	5	5	7	12	18	5	7
	250	3	3	3	3	4	7	10	3	4
	400	3.5	3	3	3	3	6	9	3	3
1000	9.5	1	1	1	1	2	3	1	1	
2000	16.5	-	-	-	-	1	1	-	-	
Halogen metal-vapour lamps parallel correction	35	0.25	5	5	5	6	36	50	5	6
	70	0.45	2	2	2	3	18	25	2	3
	150	0.75	1	1	1	1	11	15	1	1
	250	1.5	-	-	-	1	6	9	-	1
	400	2.5	-	-	-	1	6	8	-	1
1000	5.8	-	-	-	-	2	3	-	-	
2000	11.5	-	-	-	-	1	2	-	-	
High-pressure sodium-vapour lamps uncorrected	150	1.8	5	5	5	6	17	22	5	6
	250	3	3	3	3	4	10	13	3	4
	400	4.7	2	2	2	2	6	8	2	2
	1000	10.3	-	-	-	1	3	3	-	1
	High-pressure sodium-vapour lamps parallel correction	150	0.83	1	1	1	1	11	16	1
250		1.5	-	-	-	1	6	10	-	1
400		2.4	-	-	-	-	4	6	-	-
1000		6.3	-	-	-	-	2	3	-	-
Low-pressure sodium-vapour lamps uncorrected		18	0.35	22	22	22	27	71	90	22
	35	1.5	7	7	7	9	23	30	7	9
	55	1.5	7	7	7	9	23	30	7	9
	90	2.4	4	4	4	5	14	19	4	5
	135	3.5	3	3	3	4	10	13	3	4
180	3.3	3	3	3	4	10	13	3	4	
Low-pressure sodium-vapour lamps parallel correction	18	0.35	6	6	6	7	44	66	6	7
	35	0.31	1	1	1	1	11	16	1	1
	55	0.42	1	1	1	1	11	16	1	1
	90	0.63	1	1	1	1	8	12	1	1
	135	0.94	-	-	-	-	4	7	-	-
180	1.16	-	-	-	-	5	8	-	-	

* Note: In case several contactors are mounted close to each other, you need to use a installation spacer between every other contactor.

EAN codes for VS

VS120	VS220	VS420
VS120-01 24V AC/DC: 8595188129848	VS220-02 24V AC/DC: 8595188129381	VS420-31 24V AC: 8595188129442
VS120-01 230V AC/DC: 8595188123105	VS220-02 110V AC/DC: 8595188138628	VS420-31 110V AC: 8595188129466
	VS220-02 230V AC/DC: 8595188121422	VS420-31 230V AC: 8595188121446
VS120-10 24V AC/DC: 8595188129367		
VS120-10 230V AC/DC: 8595188123112	VS220-11 24V AC/DC: 8595188129374	VS420-40 12V AC: 8595188129459
	VS220-11 48V AC/DC: 8595188129398	VS420-40 24V AC: 8595188129435
	VS220-11 110V AC/DC: 8595188130790	VS420-40 48V AC: 8595188138581
	VS220-11 230V AC/DC: 8595188121408	VS420-40 230V AC: 8595188121439
	VS220-20 24V AC/DC: 8595188125253	
	VS220-20 48V AC/DC: 8595188129411	
	VS220-20 110V AC/DC: 8595188129428	
	VS220-20 230V AC/DC: 8595188121392	
VS425	VS440	VS463
VS425-04 24V AC/DC: 8595188129527	VS440-04 24V AC/DC: 8595188129299	VS463-22 24V AC/DC: 8595188129794
VS425-04 48V AC/DC: 8595188129558	VS440-04 110V AC/DC: 8595188129305	VS463-22 230V AC/DC: 8595188121514
VS425-04 110V AC/DC: 8595188160032	VS440-04 230V AC/DC: 8595188121484	
VS425-04 230V AC/DC: 8595188121682		VS463-31 24V AC/DC: 8595188129596
	VS440-22 24V AC/DC: 8595188129787	VS463-31 110V AC/DC: 8595188137904
VS425-13 230V AC/DC: 8595188129473	VS440-22 230V AC/DC: 8595188121477	VS463-31 230V AC/DC: 8595188121507
VS425-22 24V AC/DC: 8595188129541	VS440-31 24V AC/DC: 8595188129572	VS463-40 24V AC/DC: 8595188129589
VS425-22 230V AC/DC: 8595188121675	VS440-31 230V AC/DC: 8595188121460	VS463-40-48V AC/DC: 8595188160612
		VS463-40 110V AC/DC: 8595188140652
VS425-31 24V AC/DC: 8595188129497	VS440-40 24V AC/DC: 8595188129565	VS463-40 230V AC/DC: 8595188121491
VS425-31 48V AC/DC: 8595188137898	VS440-40 110V AC/DC: 8595188138567	
VS425-31 110V AC/DC: 8595188129534	VS440-40 230V AC/DC: 8595188121453	
VS425-31 230V AC/DC: 8595188121668		
VS425-40 24V AC/DC: 8595188129480		
VS425-40 48V AC/DC: 8595188136174		
VS425-40 230V AC/DC: 8595188121651		

EAN codes for VSM

VSM220	VSM425
VSM220-02 24V AC: 8595188129817	VSM425-04 24V AC: 8595188129831
VSM220-02 230V AC: 8595188128100	VSM425-04 230V AC: 8595188128155
VSM220-11 24V AC: 8595188129800	VSM425-22 24V AC: 8595188129336
VSM220-11 230V AC: 8595188128094	VSM425-22 230V AC: 8595188128148
VSM220-20 12V AC: 8595188138369	VSM425-31 24V AC: 8595188129824
VSM220-20 24V AC: 8595188128117	VSM425-31 230V AC: 8595188128131
VSM220-20 110V AC: 8595188160223	
VSM220-20 230V AC: 8595188128087	VSM425-40 12V AC: 8595188160049
	VSM425-40 24V AC: 8595188128162
	VSM425-40 230V AC: 8595188128124

EAN codes for VSK

VSK-11:	8595188121613
VSK-20:	8595188121606

Main regulations for correct use of products	122
Product loadability	123
Electro-magnetic compatibility of products	125
EMC chart	126
Overview of tested types of light sources and the loads	127
Products packing	128
Dimensions	129
Examples of usage	136
Support of project designing	145

To ensure correct and perfect function of a device and its safe operation, it is necessary to ensure and observe several main regulations:

- 1. Device supply**
 - it is necessary to ensure continuous supply of the device without drops and voltage peaks. It is mainly important for device (e.g. dimmers) where there is synchronization managed by sine wave of the main and fault in the main ca cause unreliable function of the device
 - it is necessary to observe correct connection of terminals, and in case of DC supply voltage also polarity
 - it is necessary to observe allowed tolerance of the size of supply voltage which is given by technical parameters of individual devices

- 2. Protection of the device**
 - it is necessary to ensure protection of the device by adequate elements of overvoltage protection – by fuses, by surge arrestors

- 3. Elimination of disturbances on input circuits**
 - it is recommended to eliminate disturbances on control inputs of devices by suitable elements (R-C elements) and thus minimize creation of inductive voltage on incoming wires
 - pay attention when connecting control inputs and keep in mind max. current and min. voltage at rest, which can cause spontaneous switching of device (e.g. connected glow lamps)

- 4. Operating conditions**
 - to assure the granted life and correct functions of device, there is not recommended to leave the device in extreme conditions that could negative way influence the correct device functions - permanent temperature influence over 70°C, aggressive exhalations, chemicals, high relative humidity over 95%, high electromagnetic field or microwave radiation
 - for error-free function it is necessary to avoid device placement close to electromagnetic interference source
 - all mentioned products fulfill the EMC requirements in accordance with EU Directive 89/336/EEC. Notwithstanding it is necessary to pay attention when devices are connected to circuit with electrical appliances that produce electromagnetic interference (contactors, motors), and pay attention to close power cables. It is recommended that device connecting cables (supply and control inputs) are possibly short and go separately from power cables. In case the device is connected to circuit with contactors or motors, it is necessary to protect the device with appropriate extern protection components - RC members, varistors or surge voltage protector.
 - when you use AL wires, it is necessary to follow requirements of ČSN standard 370606: 1959 and ČSN 370606 amendment 2: 1992

- 5. Device handling and using**
 - input terminals do not fill-in with high power (for serial terminals max 0.5 N/m), do not give excessive pressure to carrier terminal parts to avoid damage of inner device construction
 - protect the device before falls and excessive vibrations that could damage relays contacts
 - do not overload input relay's contacts, especially when using loads with other category then AC1
 - when at switching of big loads the relay contacts get sealed it is necessary to use inserted contactor or power relay tuned to required load for given application

Description of used protection elements in device

All time and monitoring relays from our assortment are equipped with protective elements (varistors) against possible overvoltage in supply main. Limit voltage of used varistors is 275 V. At short-time overvoltage in supply main varistor decrease its leak resistor and accumulate arisen overvoltage. When this overvoltage behave as short-time peak, varistor is able to react and protect the device against negative influences. As other protection elements there are used transils and zener diodes that eliminate overvoltage impulses in supply and input circuits of device (e.g. when switching inductive loads). In case of switching inductive loads it is recommended to separate a supply of power element (motors, contactors etc.) from supply of measuring and control device inputs.

On the charts bellow you can see oscilographic running of disconnecting of loads (contactors) and reaction of protective elements to arisen voltage pikes.

Process of disconnection of contactor with coil on 230V/AC without R-C member

Process of disconnection of contactor with coil on 230V/AC and R-C member 390 Ohm-330 nF

Process of disconnection of contactor with coil and limited varistor on 230V/AC

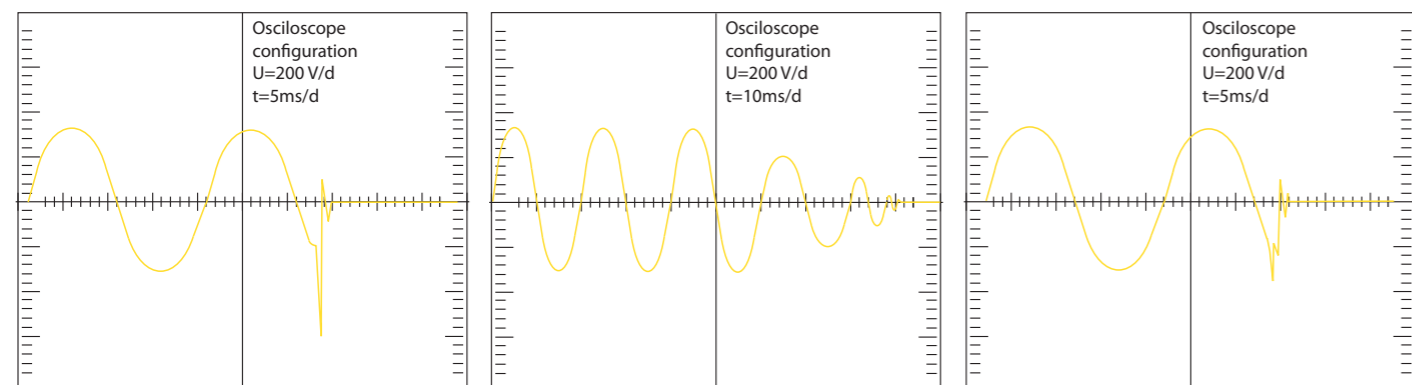

PRODUCT	SOU-2	RHV-1; SOU-3; TEV-4	CRM-4; CRM-42; HRH-7; MR-41; MR-42; SHT-1; SHT-1/2; SHT-3; SHT-3/2; SHT-4; SHT-6; SMR-B; SOU-1; RHT-1; TER-3A; TER-3B; TER-3C; TER-3D; TER-3E; TER-3F; TER-3G; TER-3H; VS116K; VS116U; VS316/24V; VS316/230V	CRM-82TO; CRM-83J; CRM-93H; PRM-2H; PRM-92H; TER-7; VS308K; VS308U; CRM-61; HRH-5; HRN-54; HRN-54N; HRN-55; HRN-55N; HRN-56; HRN-57; HRN-57N; PRI-32; PRI-51; PRI-52; PRI-53; HRF-10; TER-9	HRH-6	ATC; ATF; ATR; DTC; DTF; DTR; COS-1; CRM-2H; CRM-2HE; CRM-2T; CRM-81J; CRM-91H; CRM-91HE; HRH-1; HRN-33; HRN-34; HRN-35; HRN-37; HRN-41; HRN-42; HRN-43; HRN-43N; HRN-63; HRN-64; HRN-67; PDR-2; PRI-41; PRI-42; PRM-91H; SJR-2; TER-4; TEV-1; TEV-2; TEV-3
CONTACT	Material of contact AgSnO ₂ contact 8A	Material of contact AgSnO ₂ contact 12A	Material of contact AgSnO ₂ contact 16A	Material of contact AgNi contact 8A	Material of contact AgNi contact 10A	Material of contact AgNi contact 16A
TYPE OF LOAD						
AC1	250V / 8A	250V / 12A	250V / 16A	250V / 8A	250V / 10A	250V / 16A
AC2	250V / 5A	250V / 3.7A	250V / 5A	250V / 3A	250V / 3A	250V / 5A
AC3	250V / 4A	250V / 2.2A	250V / 3A	250V / 2A	250V / 2A	250V / 3A
AC5a uncompensated	x	230V / 2.2A (510VA)	230V / 3A (690VA)	230V / 1.5A (345VA)	230V / 2A (460VA)	230V / 3A (690VA)
AC5a compensated	x	230V / 2.2A (510VA) till max output C=14UF	230V / 3A (690VA) till max output C=14UF	x	x	x
AC5b	250W	1 120W	1000W	300W	500W	800W
AC6a	250V / 4A	x	x	x	x	x
AC7b	250V / 1A	250V / 2.2A	250V / 3A	250V / 1A	250V / 2A	250V / 3A
AC12	250V / 1A	250V / 7.5A	x	250V / 1A	250V / 6A	250V / 10A
AC13	x	250V / 4.5A	x	x	250V / 3.8A	250V / 6A
AC14	250V / 4A	250V / 4.5A	250V / 6A	250V / 3A	250V / 3.8A	250V / 6A
AC15	250V / 3A	250V / 4.5A	250V / 6A	250V / 3A	250V / 3.8A	250V / 6A
DC1	30V / 8A	24V / 12A	24V / 10A	24V / 8A	24V / 10A	24V / 16A
DC3	30V / 3A	24V / 4.5A	24V / 3A	24V / 3A	24V / 3.8A	24V / 6A
DC5	30V / 2A	24V / 3A	24V / 2A	24V / 2A	24V / 2.5A	24V / 4A
DC12	30V / 8A	24V / 12A	24V / 6A	24V / 8A	24V / 10A	24V / 16A
DC13	30V / 2A	24V / 1.5A	24V / 2A	24V / 2A	24V / 1.3A	24V / 2A
DC14	x	24V / 1.5A	x	x	24V / 1.3A	24V / 2A

Problematic choice of suitable relay contact for a particular load switched with a product is described below. Mostly we experience problems with incorrect choice of load (meaning incorrect relay for a particular load) which results in permanent switching of contact (sealing) or damage on relay contact – which then results in malfunction. What load can you use? Detailed types of load according to standard EN 60947 are described in charts below – categories of use.

Category of use	Typical use	EN
AC current, $\cos\phi = P/S$ (-)		
AC-1	Non-inductive or slightly inductive load, resistance furnace Includes all appliances supplied by AC current with power factor ($\cos\phi$) ≥ 0.95 Examples of usage: resistance furnace, industrial loads	60947-4
AC-2	Motors with slip-ring armature, switching off	60947
AC-3	Motors with short-circuit armature, motor switching when in operation This category applies to switching off motors with short-circuit armature while in operation. While switching, contactor switches current which is 5 up to 7 times rated current of motor.	60947-4
AC-4	Electro-motors with short-circuit armature: start up, braking by backset, changeover	60947
AC-5a	Switching of electrical gas-filled lights, fluorescent lights	60947-4
AC-5b	El. bulb switching Enables low contact loading due to resistance of cold fiber is many times smaller than the one of hot fiber.	60947-4
AC-6a	Switching of transformers	60947-4
AC-6b	Switching of capacitors	60947-4
AC-7a	Switching low inductive loads of home appliances and similar applications	60947
AC-7b	Load of motors for home appliances	60947
AC-8a	Switching of hermetically sealed motors of cooling compressors with manual reset switches against overload Hermetically sealed cooling compressors have to be placed in one box without external shaft or shaft padding and motor must operate with cooling liquid	60947
AC-8b	Switching of hermetically sealed motors of cooling compressors with manual reset switches against overload Hermetically sealed cooling compressors have to be placed in one box without external shaft or shaft padding and motor must operate with cooling liquid	60947
AC-12	Switching of semiconductor loads with separation transformers	60947-5
AC-13	Switching of semiconductor loads with separation transformers	60947-5-1
AC-14	Switching of low electro-magnetic loads (max.72 VA)	60947-5-1
AC-15	Management of alternating electro-magnetic loads This category applies to switching inductive loads with input for closed electro-magnetic circuit higher than 72 VA Use: switching coils of contactors	60947-5
AC-20	Connecting and disconnecting in unloaded states	60947-3
AC-21	Switching resistive loads, including low loading	60947-3
AC-22	Switching of mixed resistive and inductive loads, including low overloading	60947-3
AC-23	Switching of motor loads or other high inductive loads	60947-3
AC-53a	Switching of motors with short-circuit armature with semiconductor contactors	60947

Note: Category AC 15 replaces formerly used category AC 11

DC current, $t = L/R$ (s)

DC-1	Non-inductive or low inductive load, resistive furnaces	60947-4
DC-3	Shunt motors: start-up, braking by backset, reversion, resistive braking	60947-4-1
DC-5	Series motor: start-up, braking by backset, reversion, resistive braking	60947-4-1
DC-6	Non-inductive or low inductive loads, resistive furnaces – el. bulbs	60947-4-1
DC-12	Management of resistive loads and fixed loads with insulation by opto-electric element	60947-5-1
DC-13	Switching of electromagnets	60947-5-1
DC-14	Switching of electromagnetic loads in circuits with limiting resistor	60947-5-1
DC-20a(b)	Switching and breaking without load(a: frequent switching ,b: occasional switching)	60947-3
DC-21a(b)	Switching ohmic loads including limiting overloading (a: frequent switching ,b: occasional switching)	60947-3
DC-22a(b)	Switching of compound ohmic and inductive loads including limited overloads (e.g. shunt motors) (a: frequent switching, b: random switching)	60947-3
DC-23	Switching of highly inductive loads (e.g. series motors)	60947-3

How can you distinguish for which load is our product (relay) designated?

Our company record this information on a products and also in our catalogue, instruction manual and other promotional and technical material (website etc.). It is important to realize that it is not always possible to point out load because of lack of information about the device (user cannot measure $\cos\phi$) or it is not possible because of inconstancy of parameters of switched device. Manufacturer of relays records always guaranteed parameters in ideal conditions which are done by a norm (temperature, pressure, humidity, etc.) and reality can be in a lot of cases different. Category of use (classification) of a particular relay is done by material of output contacts.

Basic types of materials which are used for production of contacts for high-performance relay are:

- AgCd – suitable for switching ohmic loads. Before of harmfulness of Cd, this type of contact is remitted
- AgNi – designated for switching resistive loads , good quality switching and conducting (contact doesn't oxidate) small currents/voltages ,it is not designated for surge currents and loads with inductive component
- AgSn or AgSnO₂ –suitable for switching loads with inductive component , not suitable for switching small currents/voltages, it is more resistive to surge currents, suitable for DC voltage switching, less suitable for switching loads of ohmic type
- Wf (wolfram)-special contact designated for switching surge currents with inductive component
- with gold (AgNi/Au)- Used for "improving" contacts for low currents/ voltages , prevents oxidation

Electromagnetic compatibility (EMC) is a new scientific field which was founded in the 60s last century. It had been known only to a small number of specialists working in a military and cosmic research.

Electromagnetic compatibility EMC is defined as an ability of a device, system or a machine to show the correct operation even in an environment in which there are other sources of electromagnetic signals (natural or artificial), and also an ability not to influence negatively the environment by its own "electromagnetic action" and not to radiate signals that would disturb other devices. It is an indicator of good quality and reliability. Breach of such EMC requirements may cause several damages with catastrophic consequences.

When testing EMC of a device or system (technical and biological), it is based on so called "fundamental chain of EMC" shown in the picture. This chain shows a system problematic of EMC and we inspect all three components.

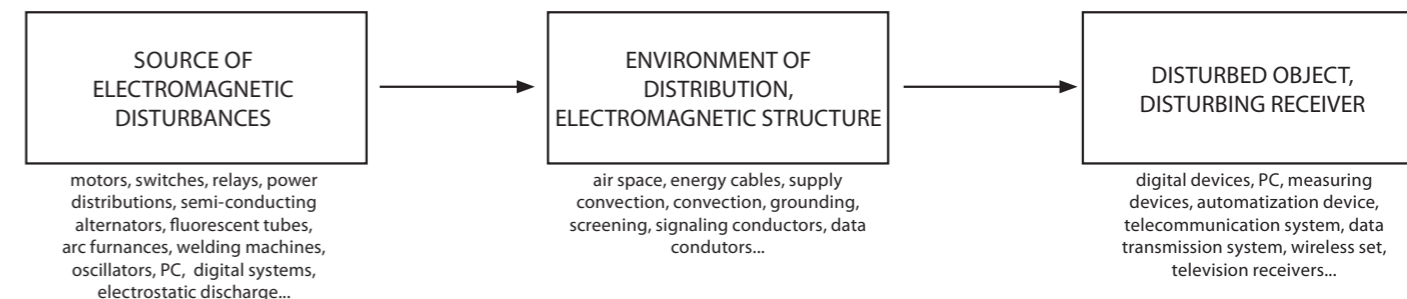
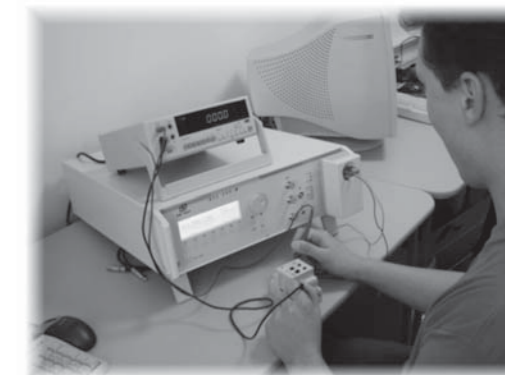

Test SURGE

For guarantee the immunity of our devices against to electromagnetic disturbance we are doing EMC tests and according results we are still innovating our product to be according the EMC norms with reserve.

The most important test is immunity against gust of high-energy voltage and current impulse (SURGE), what is made according the norm IEC 61000-4-5.

By this our products are controlled in case of short time pulse, what is applied as to input as to output circuits of devices, to switching inputs, sensing inputs, etc. Our products pass all criterias and are fully competitive to foreign products.

Test SURGE is used in practice mainly for 1-phase devices with take-off current to 16 A. It makes use of voltage impulse 1,2/50 ms no load and current impulse 8/20 ms for short time. Size of used voltage impulse is 0.5 kV, 1 kV, 2 kV and 4 kV, size of used current impulse is 2kA on 4kV with choice of changing polarity. For testing by impulses is as coup mode specify capacitive coupling.

Test BURST

Other very important test is test immunity against quick short-lived effect (couple of impulses- BURST), which dissimulated influence if industry disturbance. Test is made according to the norm IEC 61000-4-4.

Disturbance signal is injected to supply circuits and communication cabling. Coupling is made by 1-phase capacitive circuit or coupling capacitive ribband to supply, signalling or data convection of tested device. Size of testing impulses is 0.5 kV, 1 kV, 2 kV and 4 kV in positive and negative polarity. Repeat frequency is 2.5 kHz, or 5 kHz. Period of testing 0 - 6 minut by steps for 0.1s.

Test POWERFAIL

For right function of products in industry is important POWERFAIL test - simulation of decreasing and failure of supply voltage. It is made according to the IEC 61000-4-11.

Short-time supply decreasing are random decreasing of supply voltage, which are more than 10 - 15 % of its nominal size and have short time existing 0.5 - 50 periodes of basic frequency 50 Hz.

Short breaks of voltage are short time decreasing over 100 %. Mentioned changes of supply circuit voltage are made in practise by disturbance in mains (high voltage, low voltage) and breaks on load of the main.

Test of EMC emissions

Electronic devices must be designed not to be a source of oversize electric or electromagnetic disturbances in its surroundings. Test is executed according to standard EN 55022. Emissions are measured by wires or by air.

Test of electromagnetic high-frequency field and HF signal coming from the main

The purpose of this test is to verify immunity of the device against electromagnetic fields that are created by radio transmitters or by any other device which transmits electromagnetic energy by uninterrupted waves (walkie-talkies, radio and TV transmitters.)

Test is carried out against disturbances in the main and emissions. We apply testing level 3 which for HF field means intensity of field 10 V/m and for HF signal it is voltage level 10 V.

Test of electrostatic discharge

It is a test of resistance against discharges of electrostatic energy caused by servicing or by surrounding objects. Such discharge can damage a device or its components.

Test is carried out by direct or indirect application of discharges to a tested device. Test is carried out according to a standard EN 61000-4-2. Direct influence of discharges is targeted into such places and surfaces that are accessible to servicing during common use. Indirect influence of discharge is done by horizontal and vertical coupling board.

The device is treated by at least ten individual discharges for positive and negative polarity. Testing levels are 2kV, 4kV, 6kV, 8kV, 15kV.

Company ELKO EP has its own test laboratory in which it carries out pre-certification for conditions that must be met by each of our products. Thus customers gets not only a product of a high quality, which is ensured by many years of experience in the field of switching relays, but also a product which can operate in demanding conditions of industrial environment. Product, tested this way, guarantees reliability and functionality to customer's full satisfaction.

PRODUCT	STANDARD		
	levels according to CSN EN 61000-4-4	levels according to CSN EN 61000-4-5	EMC; EMISE according to norm:CSN EN
Time relays			
CRM-81J/230V	3	3	55022/A
CRM-81J/UNI	3	3	55022/A
CRM-83J/230V	3	3	55022/A
CRM-83J/UNI	3	3	55022/A
CRM-82TO	3	3	55022/A
SJR-2/230V	3	3	55022/B
SJR-2/UNI	3	3	55022/A
CRM-2T/230V	3	3	55022/B
CRM-2T/UNI	3	3	55022/A
CRM-2H/230V	3	3	55022/A
CRM-2H/UNI	3	3	55022/A
CRM-91HE/UNI	3	3	55022/A
CRM-2HE/UNI	3	3	55022/A
CRM-91H/230V	3	3	55022/B
CRM-91H/UNI	3	3	55022/A
CRM-93H/230V	3	3	55022/B
CRM-93H/UNI	3	3	55022/A
CRM-95	-	3	61000-6-3
CRM-61	3	2	61000-6-3
SHT-1	3	3	55022/A
SHT-1/2	3	3	55022/A
SHT-3	3	3	55022/A
SHT-3/2	3	3	55022/A
PDR-2A/230V	2	3	61000-6-3
PDR-2A/UNI	3	3	61000-6-3
PDR-2B/230V	2	3	61000-6-3
PDR-2B/UNI	3	3	61000-6-3
PRM-91H/8	3	3	55022/B
PRM-91H/11	3	3	55022/B
PRM-92H	2	3	55022/A
PRM-2H	2	3	55022/A
SMR-T	2	2	61000-6-3
SMR-H	2	2	55022/A
SMR-B	2	2	61000-6-3
CRM-4	3	3	55022/B
CRM-42	3	3	55022/A
Power and auxiliary relays			
VS116K	3	3	55022/A
VS116U	3	2	55022/A
VS308K/230V	3	3	61000-6-3
VS308K/UNI	3	2	55022/B
VS308U	3	2	55022/A
VS316/24V	3	-	-
VS316/230V	3	3	55022/B
Dimmers			
DIM-2	2	2	61000-6-3
DIM-5	2	2	61000-6-3
DIM-14	2	2	55022/B
DIM-6	2	2	55014-1
DIM6-3M-P	2	2	55014-1
DIM-15	2	2	55014-1
SMR-S	2	2	55022/A
SMR-U	2	2	55022/B
LIC-1	2	2	550015

PRODUCT	STANDARD		
	levels according to CSN EN 61000-4-4	levels according to CSN EN 61000-4-5	EMC; EMISE according to norm:CSN EN
Power supplies			
PS-10-12; PS-10-24	3	3	55022/B
PS-30-12; PS-30-24	3	3	55022/B
PS-100-12; PS-100-24	3	3	55022/B
PS-30R	3	3	55022/A/B
ZSR-30	3	3	61000-6-3
ZNP-10-12V	-	3	55022/B
ZNP-10-24V	-	3	55022/B
Other modular devices			
SOU-1/230V	3	3	61000-6-3
SOU-1/UNI	3	2	55022/A
SOU-2	3	3	61000-6-3
SOU-3	3	3	55022/B
MR-41/230V	3	3	55022/A
MR-41/UNI	3	3	55022/A
MR-42/230V	3	3	55022/A
MR-42/UNI	3	3	55022/A
Monitoring relays			
HRN-41	3	3	61000-6-3
HRN-42	3	3	61000-6-3
HRN-33	3	3	55022/A
HRN-34	3	-	-
HRN-35	3	3	55022/A
HRN-37	3	3	55022/A
HRN-63	3	3	55022/A
HRN-64	3	-	-
HRN-67	-	-	-
HRN-55	3	3	55022/B
HRN-55N	3	3	55022/B
HRN-57	3	3	55022/B
HRN-57N	3	3	55022/B
HRN-54	3	3	55022/B
HRN-54N	3	3	55022/B
HRN-56/120	3	3	55022/B
HRN-56/208	3	3	55022/B
HRN-56/240	3	3	55022/B
HRN-56/400	3	3	55022/B
HRN-56/480	3	3	55022/A
HRN-56/575	3	3	55022/A
HRN-43	3	3	55022/A
HRN-43N	3	3	55022/A
PRI-32	3	3	61000-6-3
PRI-51/1	3	3	61000-6-3
PRI-51/2	3	3	61000-6-3
PRI-51/5	3	3	61000-6-3
PRI-51/8	3	3	61000-6-3
PRI/16	3	3	61000-6-3
PRI-51/0.5	3	-	-
PRI-52	3	3	55022/A
PRI-41	3	3	61000-6-3
PRI-42	3	3	61000-6-3
HRN-1/230V	3	3	55022/A
HRH-1/24V	3	3	55022/A
HRN-1/110V	3	3	55022/A
HRN-5	3	3	61000-6-3

PRODUCT	STANDARD		
	levels according to CSN EN 61000-4-4	levels according to CSN EN 61000-4-5	EMC; EMISE according to norm:CSN EN
HRH-4/230V	3	3	55022/B
HRH-4/24V	3	3	55022/B
HRH-6/AC	3	3	61000-6-3
HRH-6/DC	3	-	-
COS-1	3	3	55022/A
Thermostats			
TER-3A	3	3	55022/B
TER-3B	3	3	61000-6-3
TER-3C	3	3	55022/B
TER-3D	3	3	61000-6-3
TER-3E	3	3	55022/B
TER-3F	3	3	55022/B
TER-3G	3	3	55022/B
TER-3H	3	3	55022/B
TER-4/230V	3	3	55022/B
TER-4/24V	3	3	-
TER-9/230V	3	3	55022/B
TER-9/24V	3	3	-
TER-7	3	3	55022/B
ATR; ATC; ATF	2	2	55022/B
DTR; DTC; DTF	2	2	55022/B
TEV-1	3	3	55022/B
TEV-2	3	3	55022/B
TEV-3	3	3	55022/B
TEV-4	3	3	55022/B
RHT-1	3	3	55022/B
RHV-1	3	3	55022/B

As is our good tradition, we have always been seeking for a maximum universality of our products. We have successfully developed a dimmer DIM-15 and SMR-M, and because the LED lighting dimming - as well as dimming of energy saving lamps - is a relatively new area and there are not so many manufacturers who produce dimmable energy saving resources, we will gradually test and expand the chart below. We welcome your feedback and cooperation in addressing us your comments and new types.

Type	Light sources ELKO Lighting	Socket	Dimmable	The maximum number of units can be connected to dimmers				
				SMR-M	LIC-1	DIM-14	DIM-15	DIM-6
DLB-E27-806-2K7		E27	yes	11	21	36	21	145
DLB-E27-806-5K		E27	yes	11	21	36	21	145
DLSL-GU10-350-3K		GU10	yes	25	45	74	45	300
LSL-GU10-350-3K		GU10	yes	13	25	40	25	165
LSL-GU10-350-5K		GU10	yes	13	25	40	25	165









Please note:

May lead to different results based on the state of network cable length and other factors.

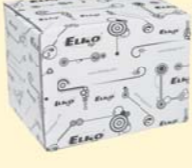
This table contains the results of tests that were conducted internally and therefore is ONLY for customers only informative.

The products were tested in test laboratories ELKO EP, and therefore the company assumes no responsibility for any imitation test environment.

Type	Light sources from manufacturers	Socket	Dimmable	Type	Light sources from manufacturers	Socket	Dimmable
	Brilum LED line 18led	GU-10D	yes		Led Philips Master 7W	GU-10	no
	Brilum LED line	GU-10P	yes		Philips LEDspot MV 4W GU10 40D	GU-10	yes
	Brilum LED line JCR-27D 48Led	E27	yes		Philips LEDspot MR 16 LV 4W GU5,3 24D	GU-5.3	no
	Elim SMD-W12	GU-10	yes		Philips LEDspot MV 3W GU10 25D	GU-10	no
	Elim SDW21	GU-10	yes		Energetic BULB Warm White 250 Lumen	E27	yes
	Elim SMD-W20	GU-10	no		Energetic BULB Clear Warm White 250 Lumen	E27	yes
	Panlux E27L1-81120/T	E27	no		Energetic Warm White Reflector GU10 600 CD	GU-10	yes
	LED LAMPJDRE27	E27	yes		Energetic Cool White Reflector GU10 550 CD	GU-10	yes
	Brilum Led line white 21led	GU10D	yes		Energetic Warm White Dimmer 1200 Lumen	E27	yes
	Osram dulux el.dimmable lumilux warm white 1230lm	E27	yes		Energetic Wram White 3 Step Dimmer 1300 Lumen	E27	no
	Megaman dimmerable 2700K DEC01	E14	yes		Energetic Wram White 3 Step Dimmer 520 Lumen	E27	no
	Lumee GU 10-60-CW-120	GU-10	yes		TR-0WGE-05	E27	no
	Lumee GU 10-P-60-CW-120	GU-10	yes		Paulmann reflector electrobnic 7W GU 10	GU-10	no
	Lumee JDRE 14-60-CW-120	E14	yes		Osram parathom classic A 40	E27	no
	Lumee Ball-80-CW	E14	yes		Osram parathom classic B 25	E14	no
	Philips Master 20W	E27	no		Osram parathom PAR16	GU-10	no
	Led Osram Decospot 0.75W	GU-10	no		EMOS 48led 2W	E14	yes
					EMOS dimmable saving fluorescent lamps 20W	E27	yes

Products	Packing	Design
COS-1, DCDA-33/RGB; HRH-1, HRN-41, HRN-42, HRN-43, PDR-2, PRI-41, PRI-42, PS-12, PS-24, PS-R, ZSR-30, ZNP-10, ZTR-10, HRN-56/480, 575	 Packing of 3-MODULE relay - 1 pc	
SHT-1, SHT-3, SHT-1/2, SHT-3/2	 Packing of 2-MODULE relay - 1 pc	
PRM-91H, PRM-92H, PRM-2H	 Packing of plug - in relay - 2 pc	
SOU-1, SOU-2, LIC-1, LIC-2, CRM-91HE, CRM-2HE	 Packing of 1-MODULE relay with accessories	
CRM-81J, CRM-83J, CRM-82TO, CRM-61, CRM-9S, CRM-2H, CRM-2T, CRM-4, CRM-42, SOU-1, DIM-2, DIM-5, DIM-14, HRH-5, HRN-33, HRN-34, HRN-35, HRN-55, HRN-55N, HRN-54, MR-41, MR-42, PRI-51, SJR-2, TER-3, TER-7, HRN-56, HRN-63, HRN-64, HRN-67, VS116K, VS116U, VS308K, VS316/24, VS316/230, USS, VS	 Packing of 1-MODULE relay - 10 pc	

1-MODULE DESIGN

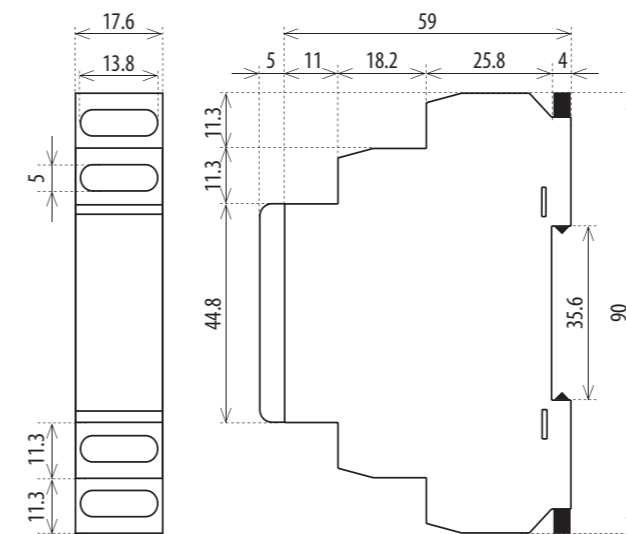

PRI-32

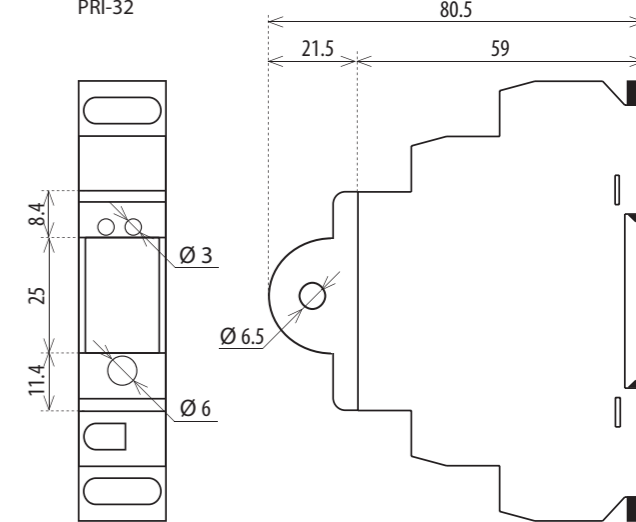

front panels 1-MODULE, examples of use:

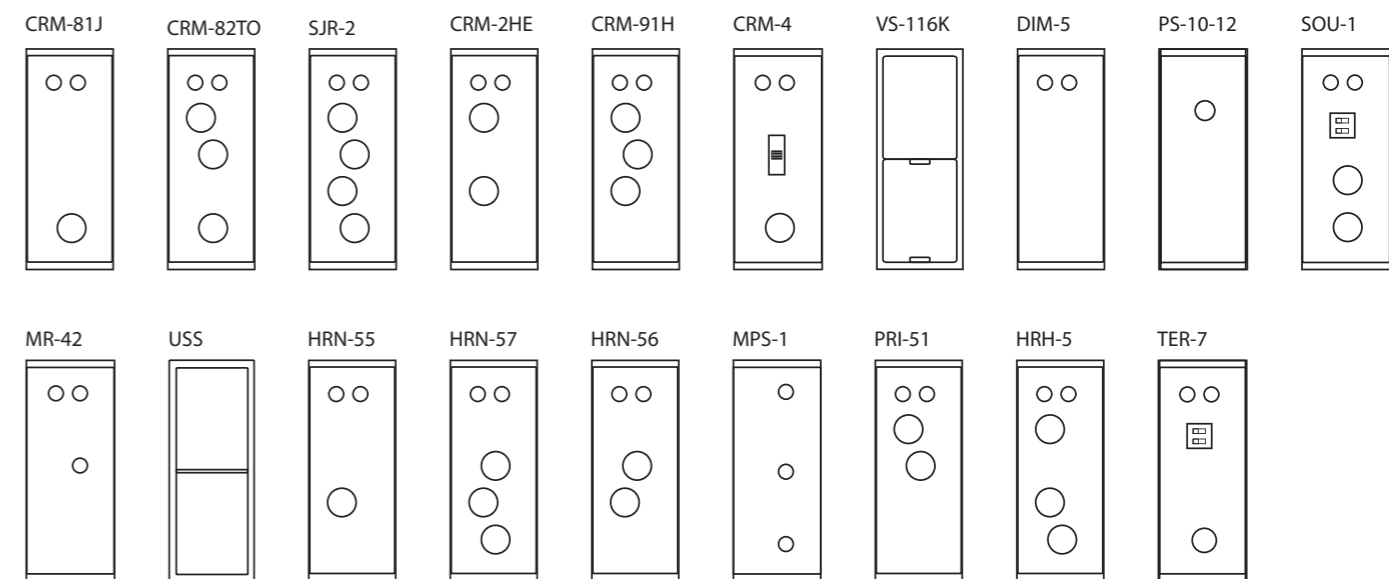

2-MODULE DESIGN

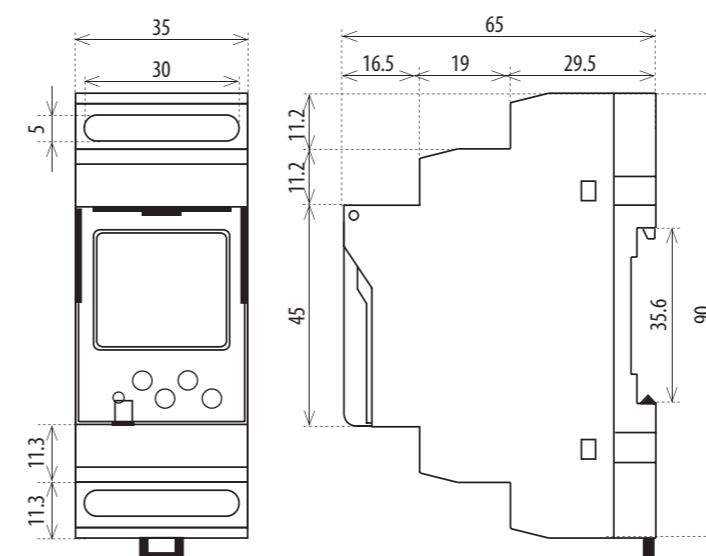

Temperature sensor

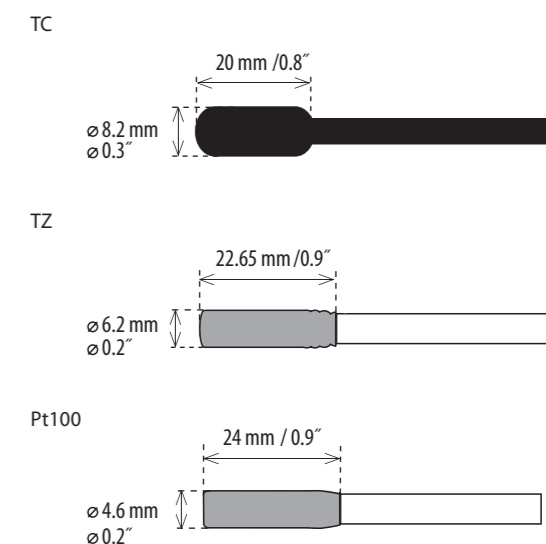

3-MODULE DESIGN

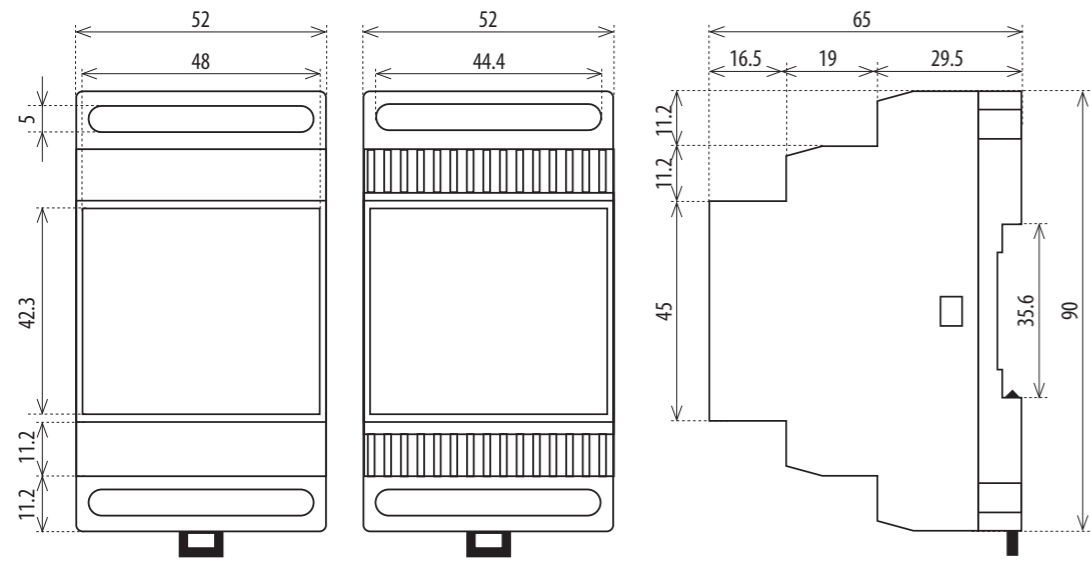

front panels 3-MODULE, examples of use:

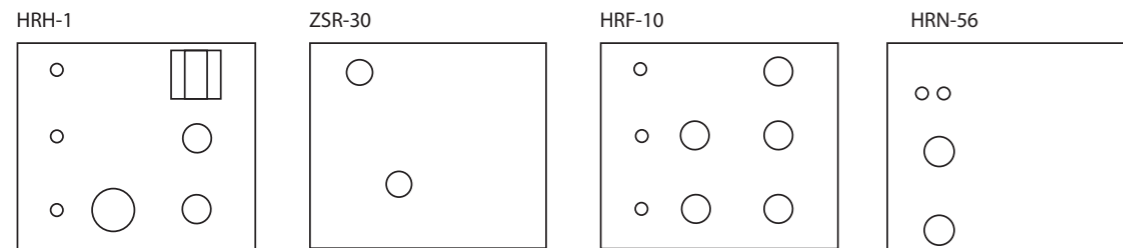
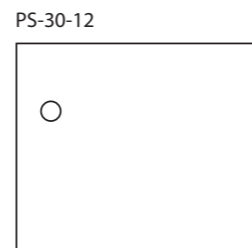
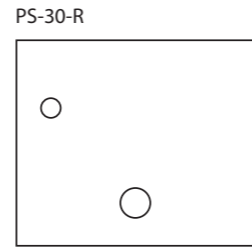
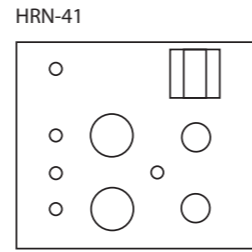

6-MODULE DESIGN

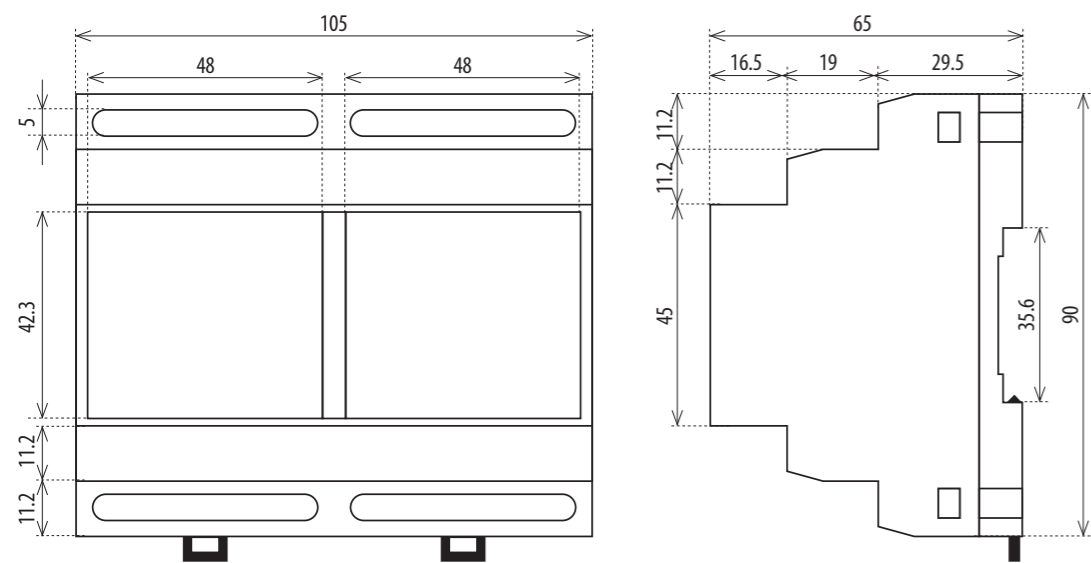

front panels 6-MODULE, examples of use:

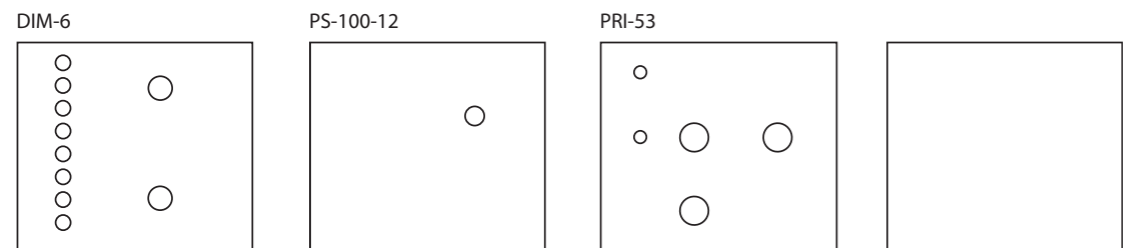

SMR-T, SMR-H, SMT-K

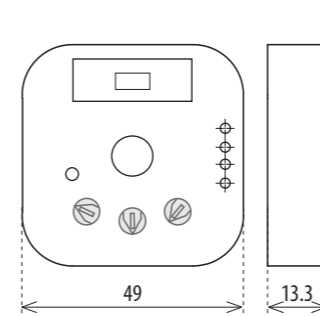

SMR-S, SMR-U

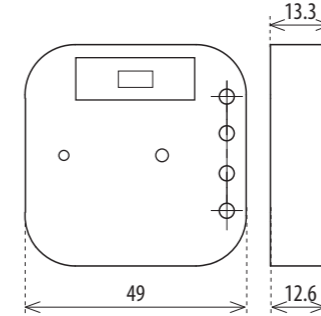

SMR-B

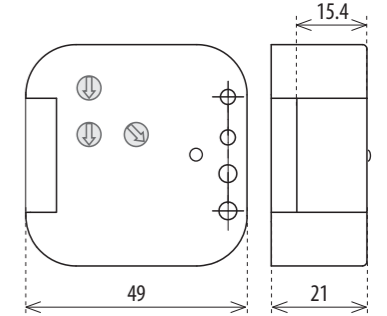

VS116/B

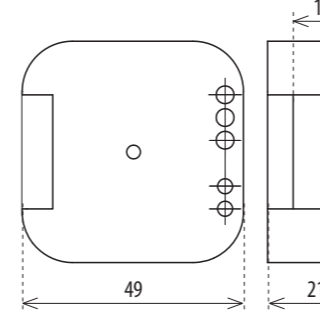

SMR-M

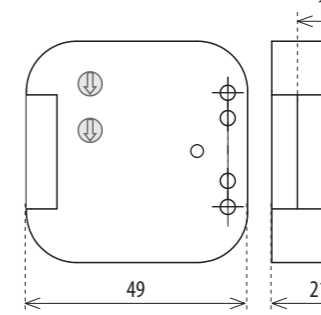

PSB

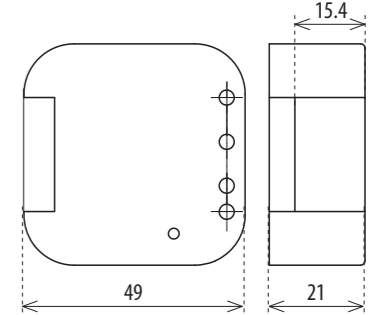

ATR, ATF, ATC

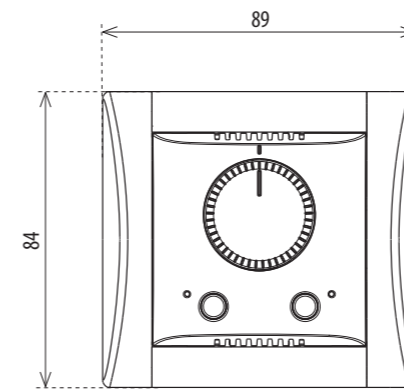

DTR, DTF, DTC

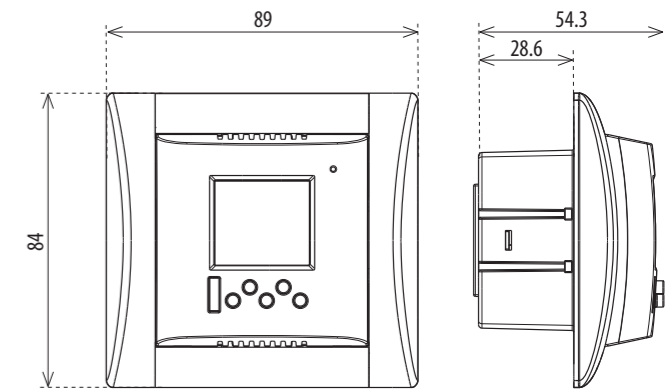

RHV-1, TEV-4

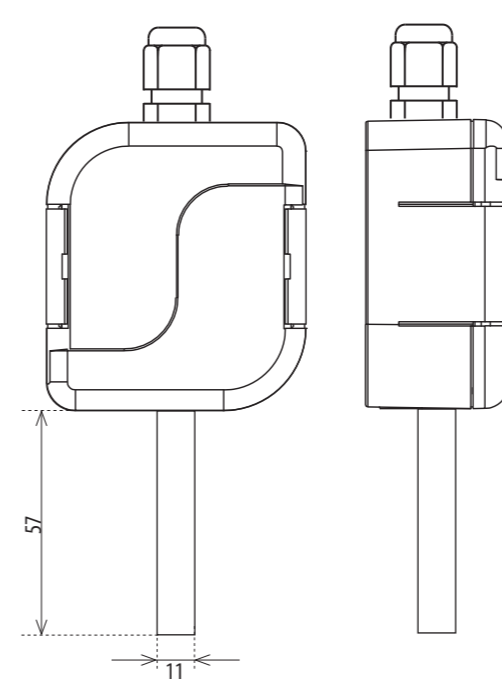

SOU-3

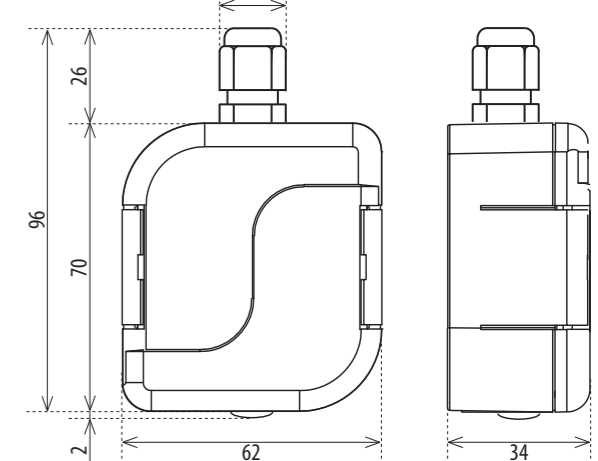

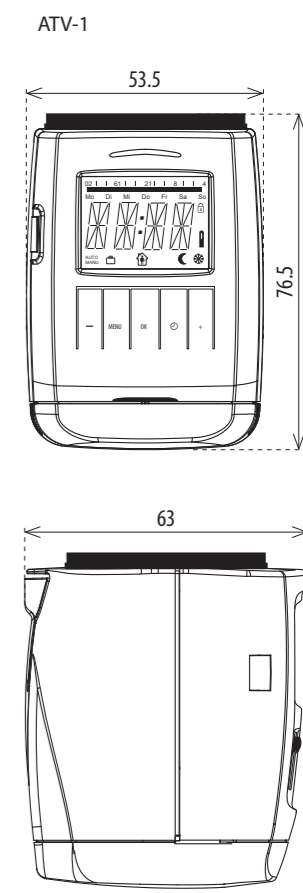
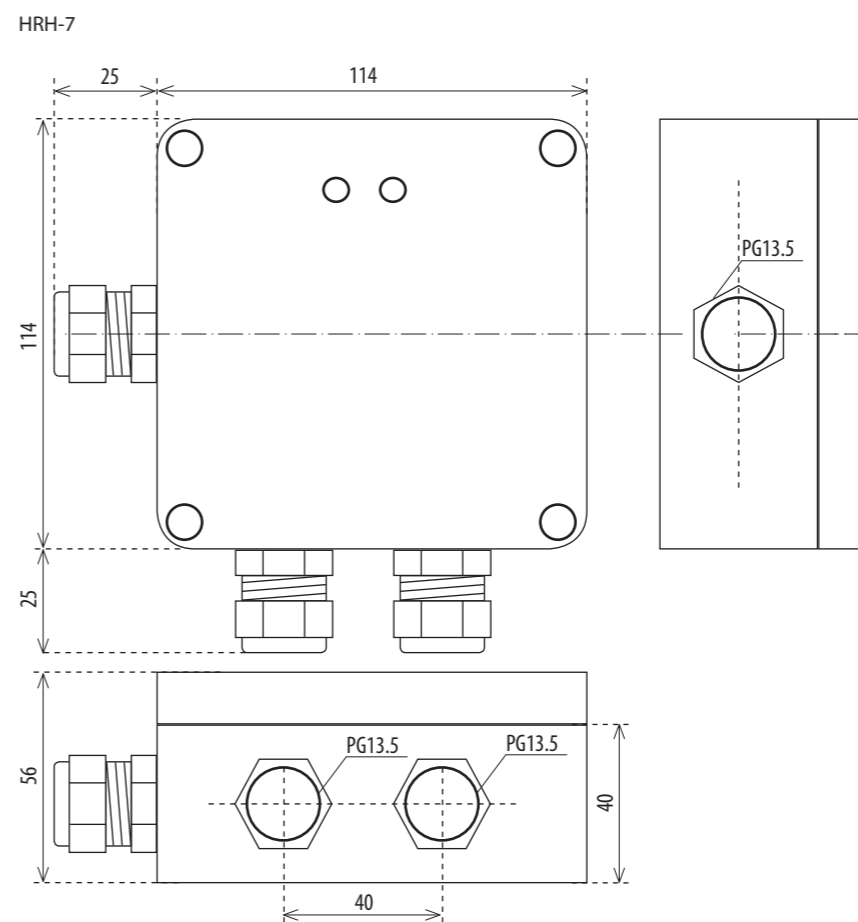
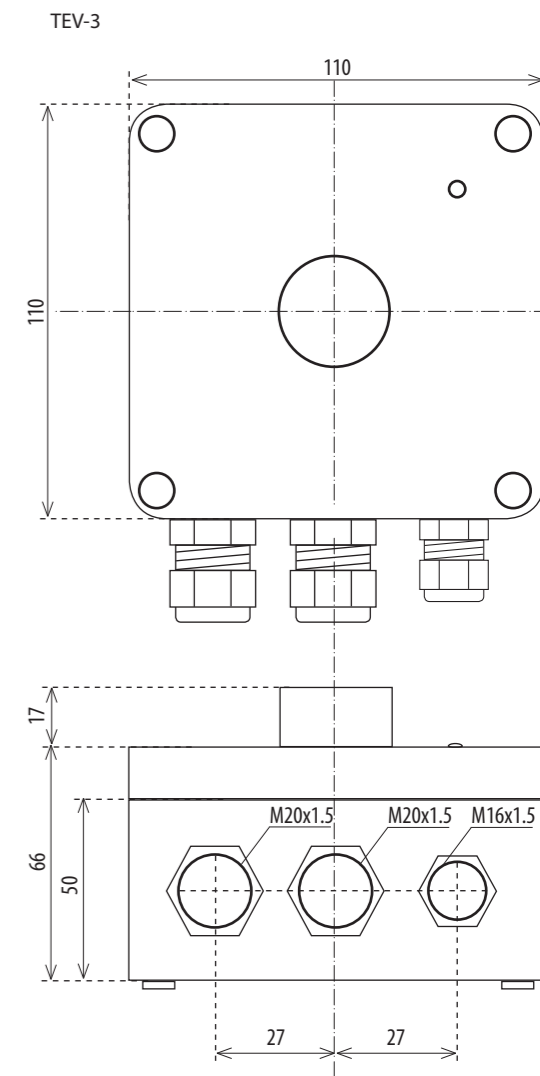
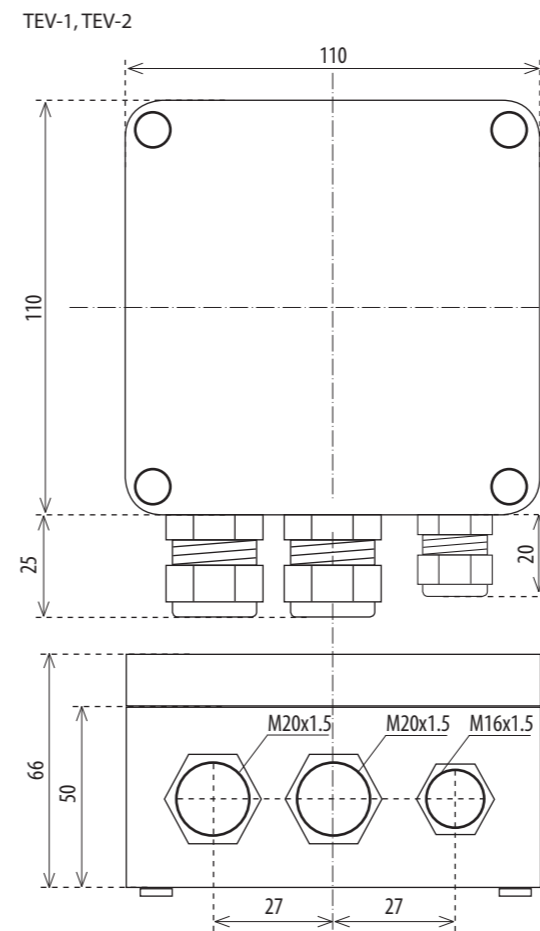
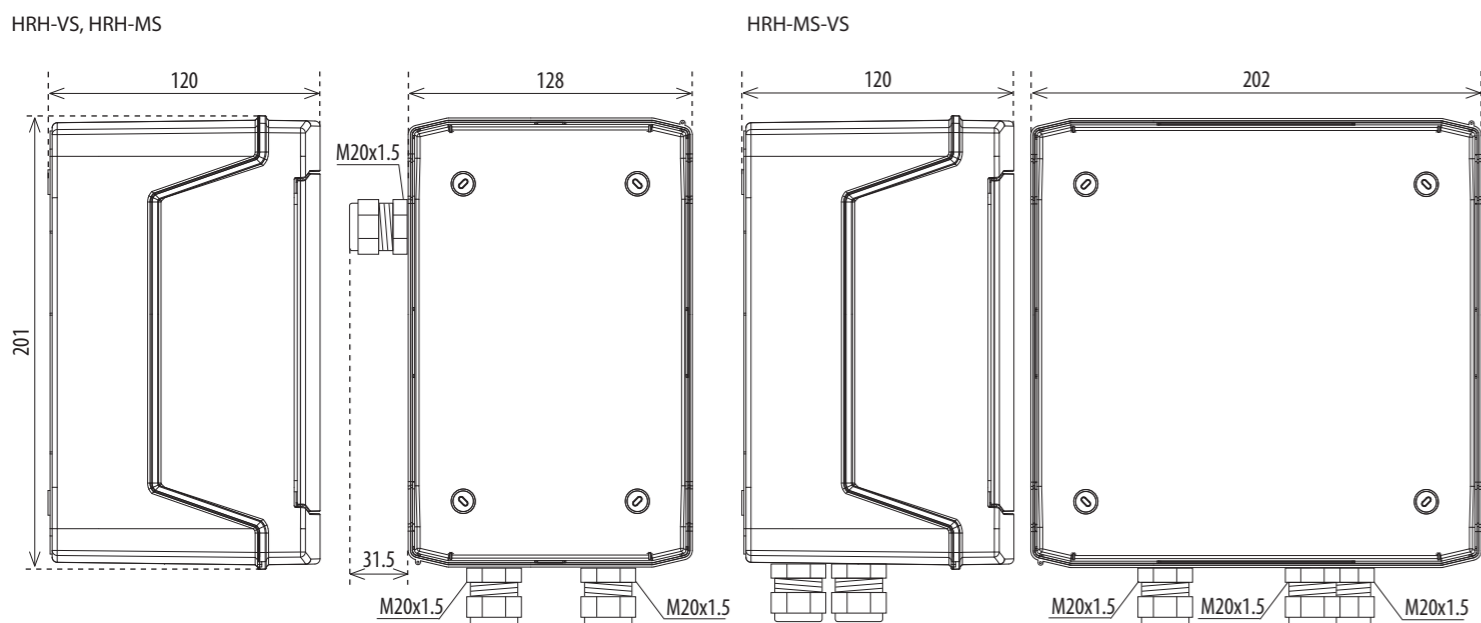
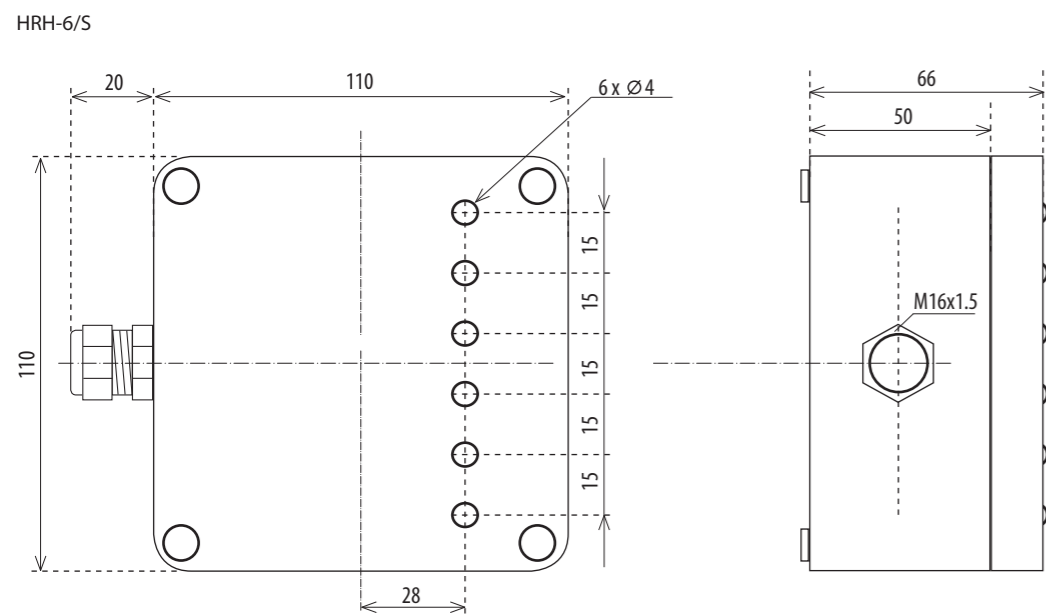
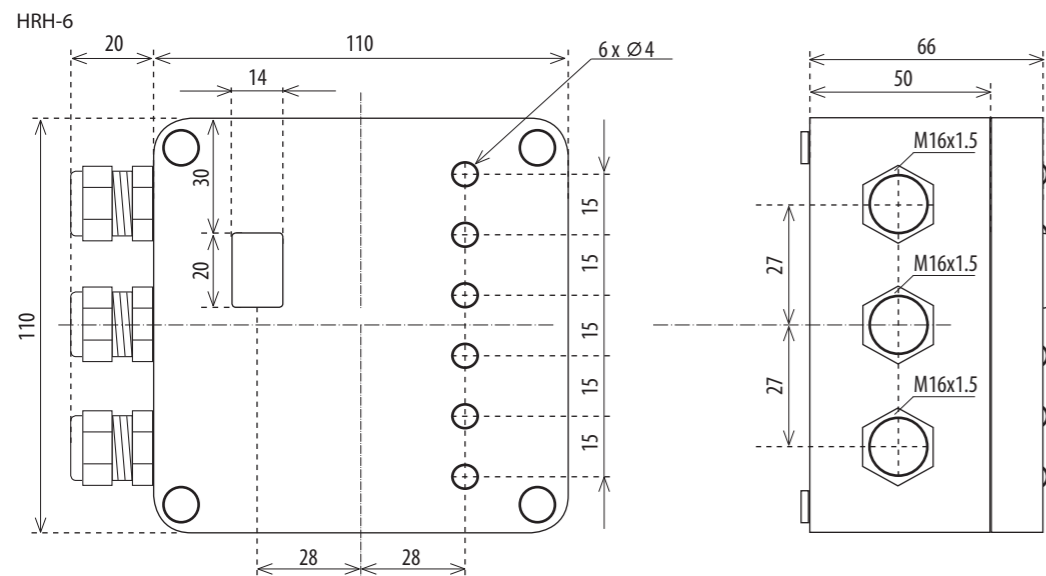

PRM-91H/11, PRM-91H/8, PRM-92H, PRM-2H

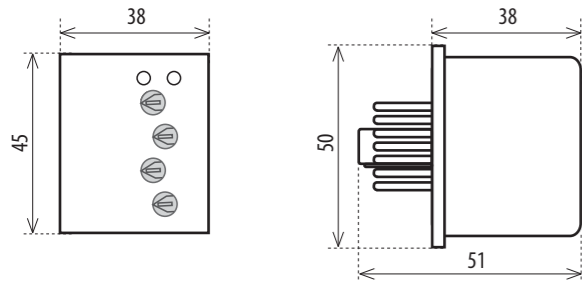

Level sensor SHR-3

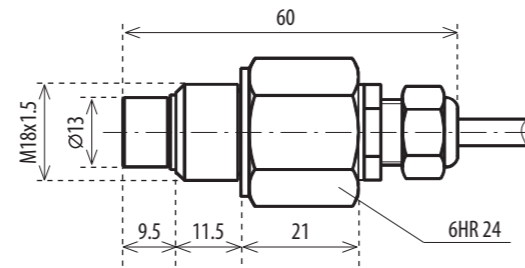

782L

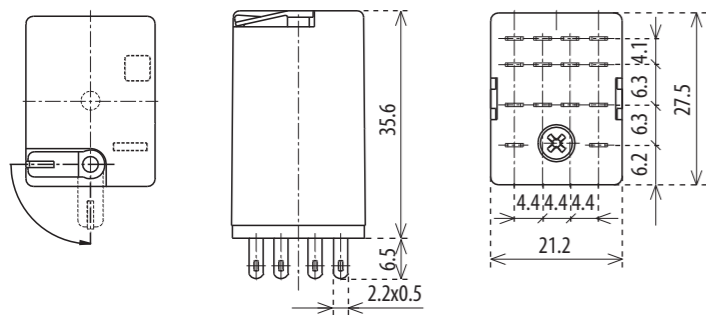

750L

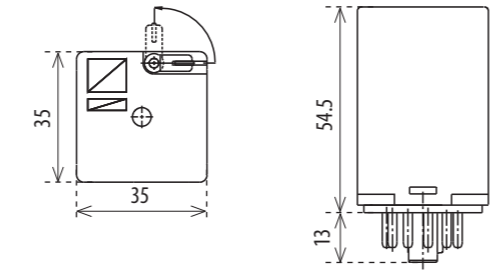

Socket for PRM-91H/11, PRM-92H, PRM-2H, 750L

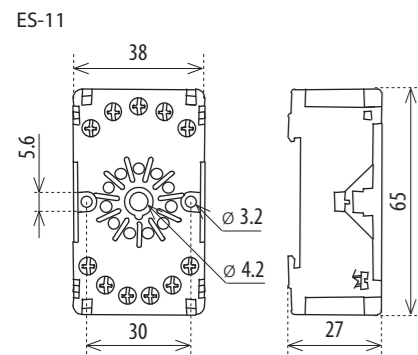

Socket for PRM-91/8

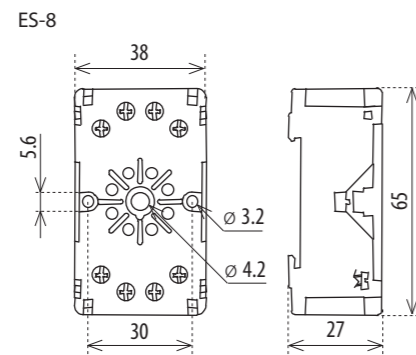

Socket for 782L

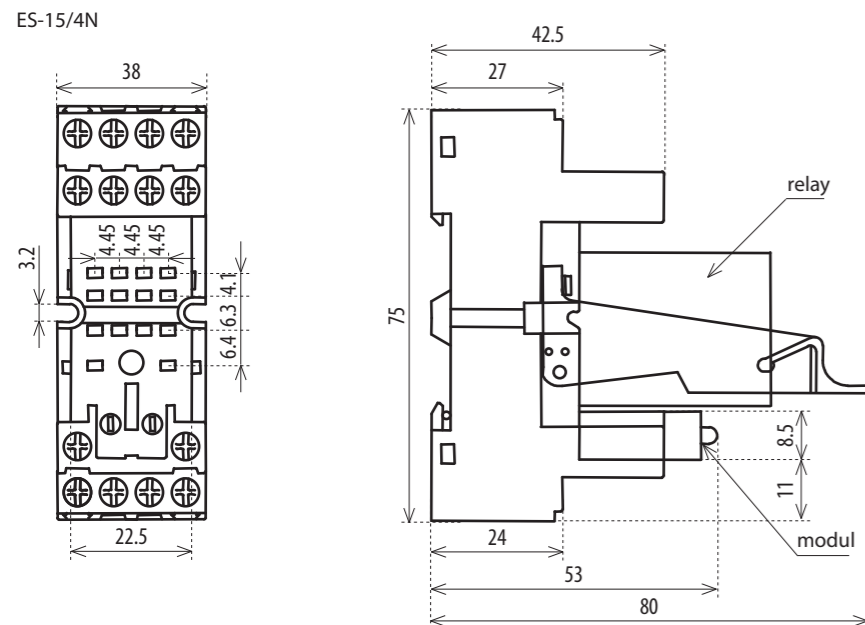

VS120
VS220
VSM220

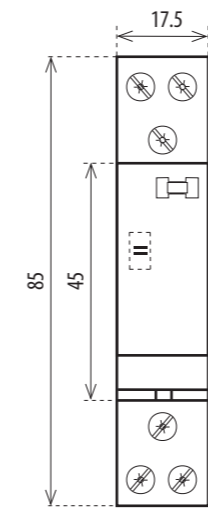

VS425
VSM425

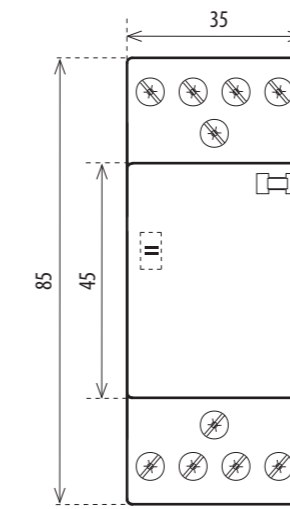

VS440
VS463

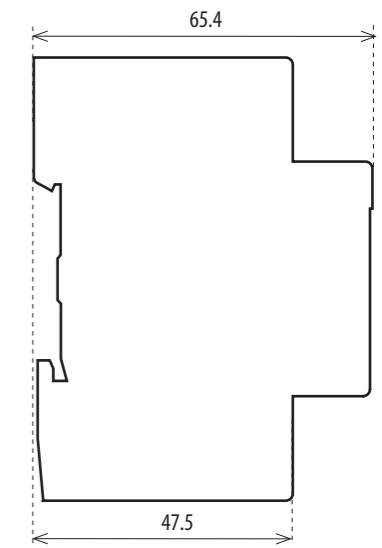
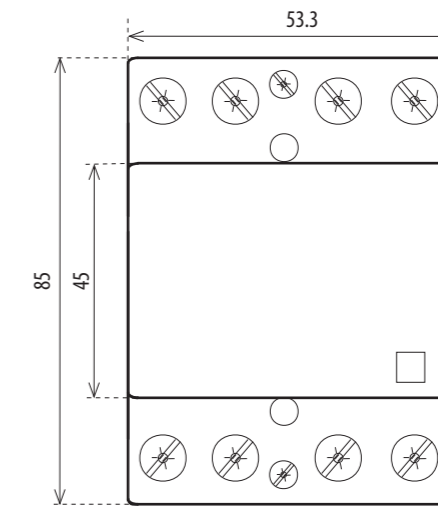

VS420

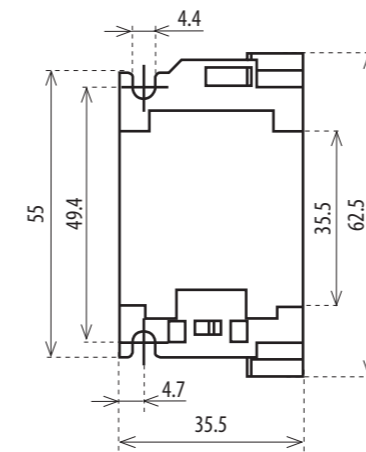

VSK-20

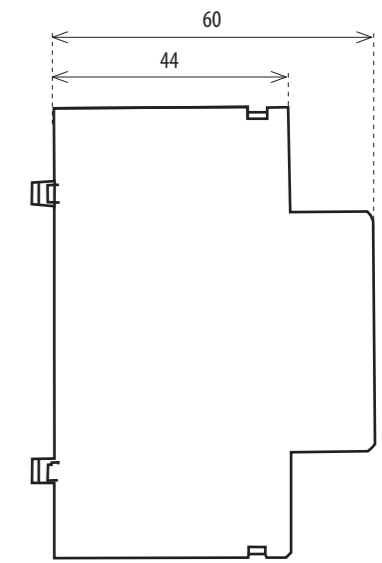
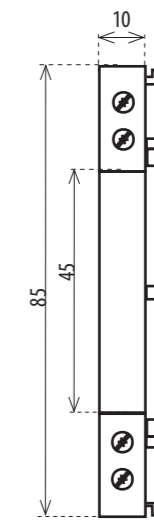

IKV

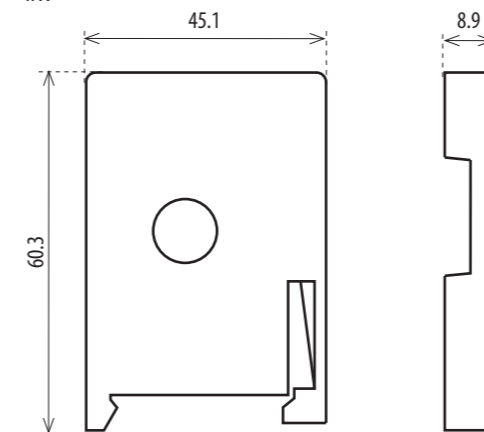

photosensor SKS

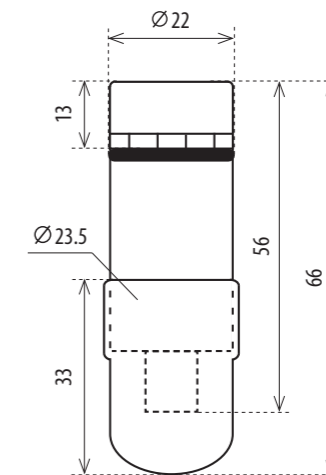

external potentiometer for CRM-2HE, CRM-91HE

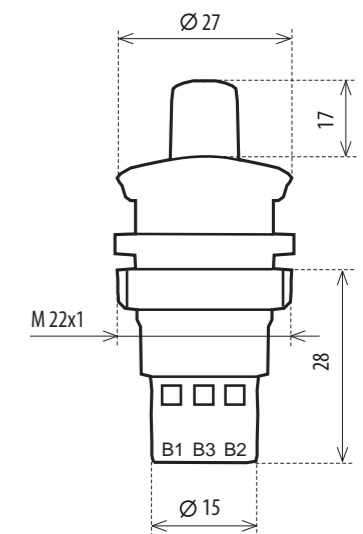

Multifunction time relay CRM-91H, CRM-93H

- for electric appliances, where is necessary to change the exact timing - controlling of the illumination, heating, motors, machines, ventilators, contactors...

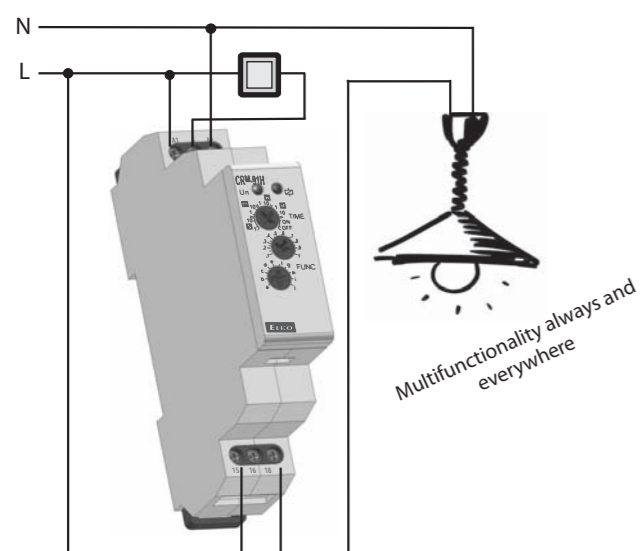

Multifunctionality always and everywhere

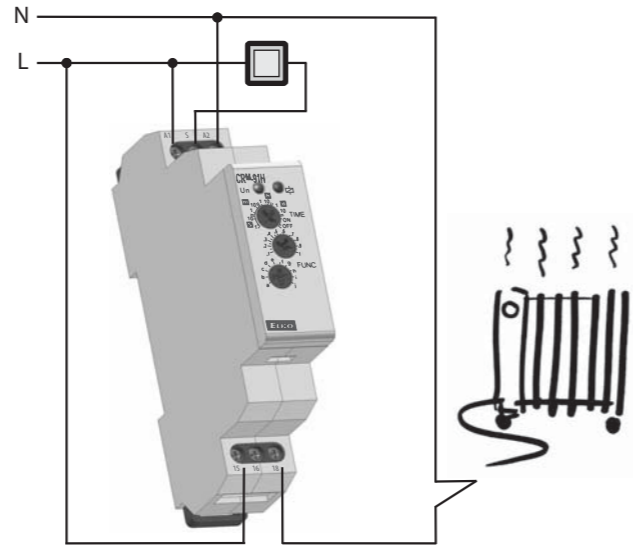

Multifunction time relay with contactless output CRM-9S

- using for warning illuminatin on the road, flashers, cyclers, often switched systems ...

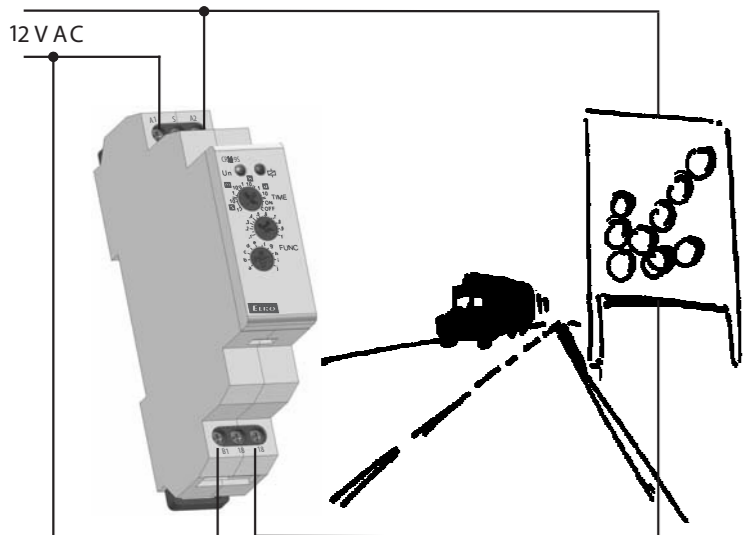

Singlefunction time relay CRM-81J

- time switch, using for run down the pump after switch off the heating, switching of ventilators ...

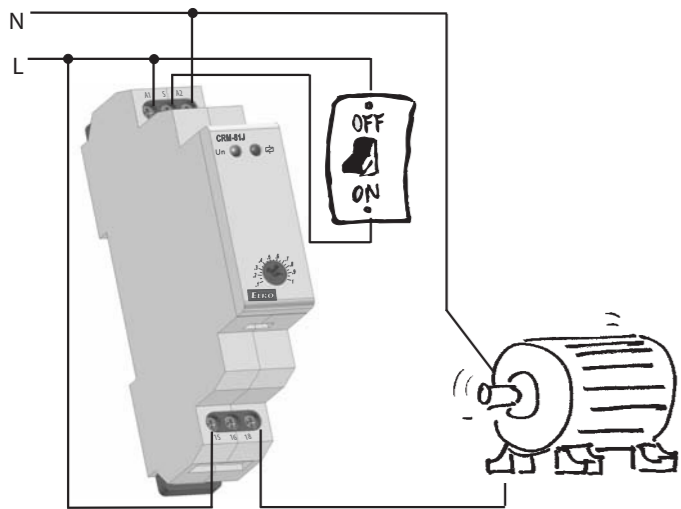

Multifunction time relay with external potentiometer CRM-91HE

- time adjusting via external operating unit, operating on panel, switchboard doors

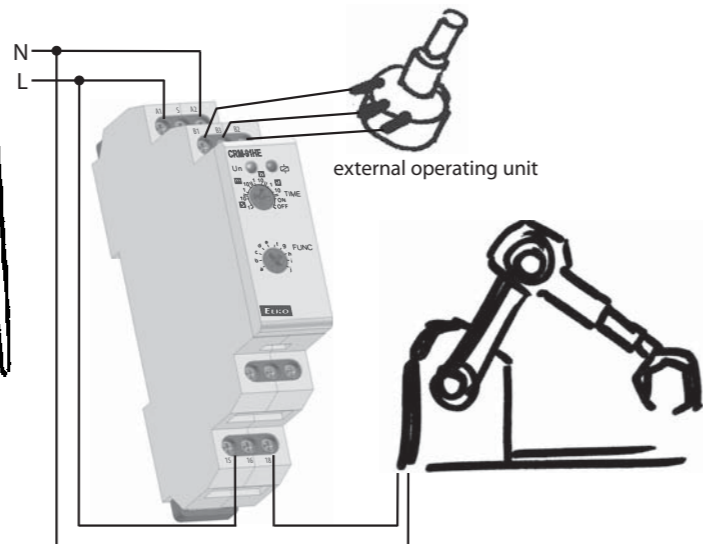

Multifunction time relay CRM-61

- for electronic appliances, light control, heating, motors, fans....

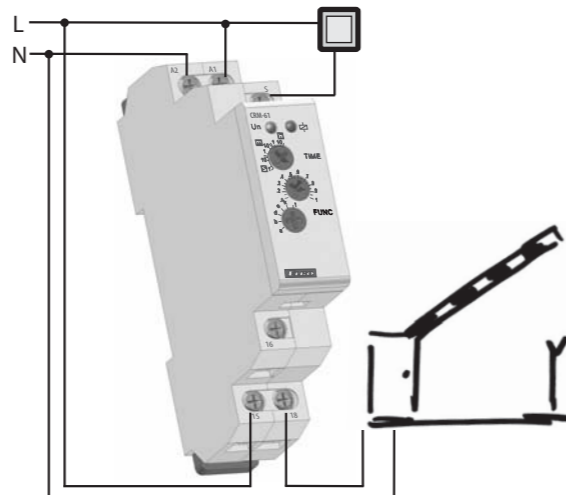

Time relay plug-in type PRM-91H, PRM-92H

- serves to control light signalization, heating, motor and fan control etc.

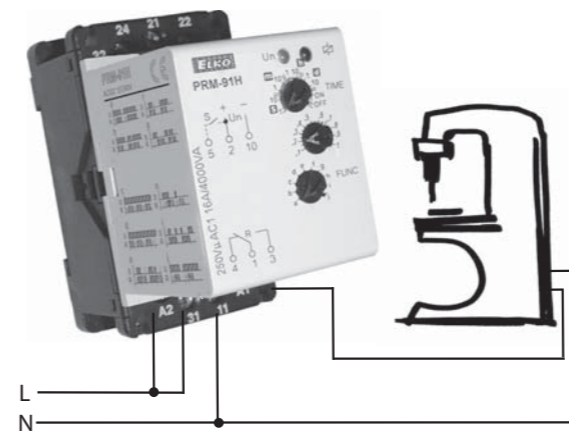

Doublestage delay unit SJR-2

- for sequential load switching, electric furnaces, heaters...

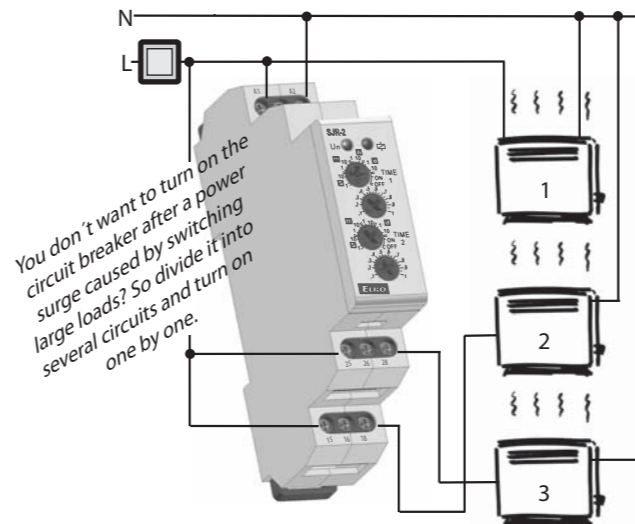

You don't want to turn on the circuit breaker after a power surge caused by switching large loads? So divide it into several circuits and turn on one by one.

Staircase switch CRM-4

- staircase automatic systems, ventilators switching, for multiplace operating illumination on the staircases and halls...

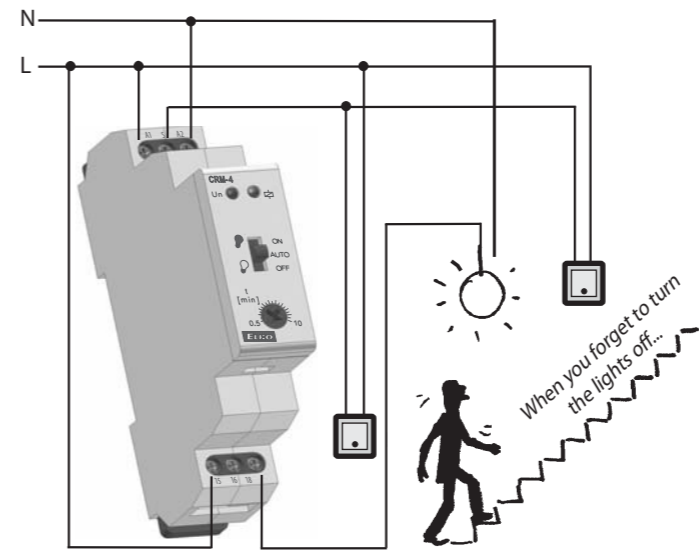

When you forget to turn the lights off...

Delay OFF without supply voltage CRM-82TO

- delayed back-up switch off at current failure (emergency illumination, emergency respirator)

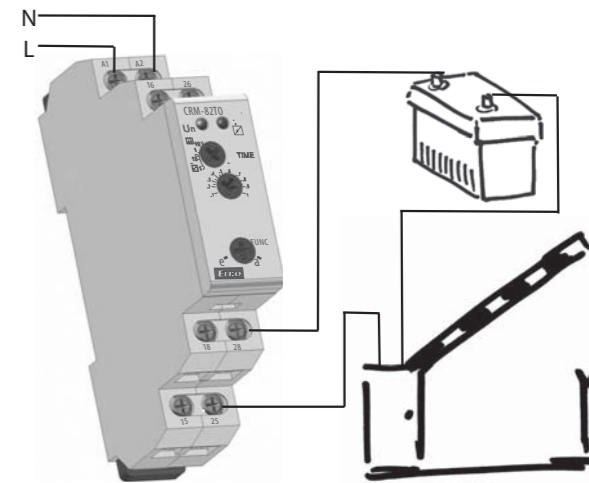

Asymmetric cycler CRM-2H - regular rooms ventilation, cyclic humidity

exhaustion, illumination controlling, circulation pump, flash, warning appliances, regular pump down, regular irrigation via electromagnetic valve

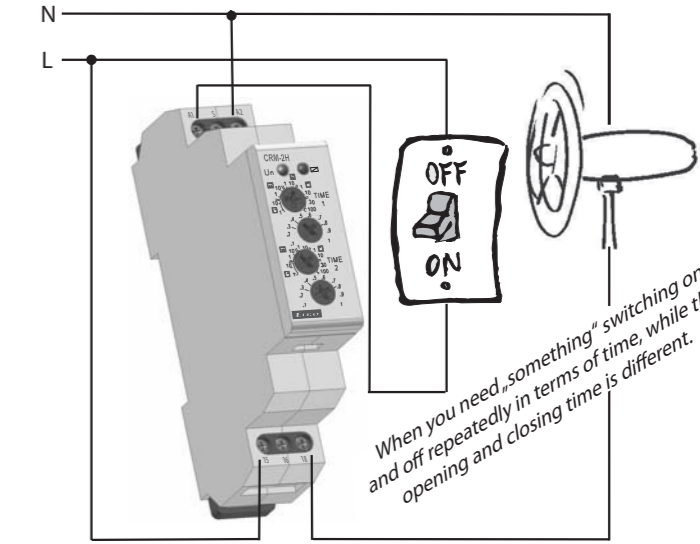

When you need „something“ switching on and off repeatedly in terms of time, while the opening and closing time is different.

Programmable staircase automat with signalling before switch off CRM-42

- staircase illumination operation - on-coming switch off signalling (flash = comfort + safety together)

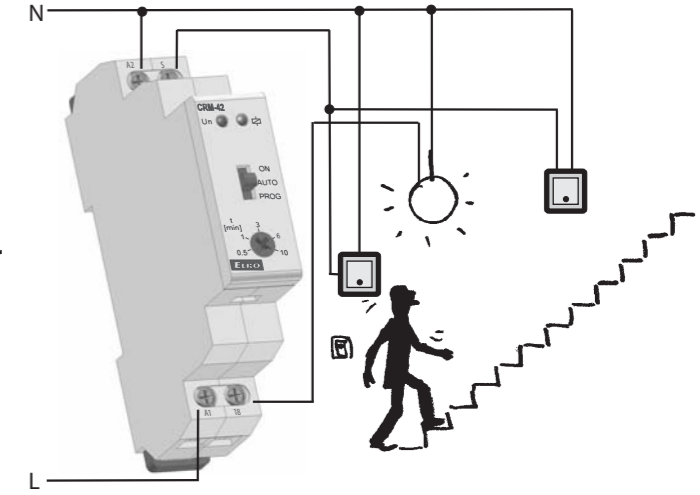

Digital time switch SHT-1/2

- for controlling of all appliances that depend on real time, appliances could be controlled in regular cycles, or according to adjusted program (blocking of main door out of working hours or night)
- in combination with other devices, controlling could be combined (rooms ventilation, irrigation controlling, bell at school or in church...)

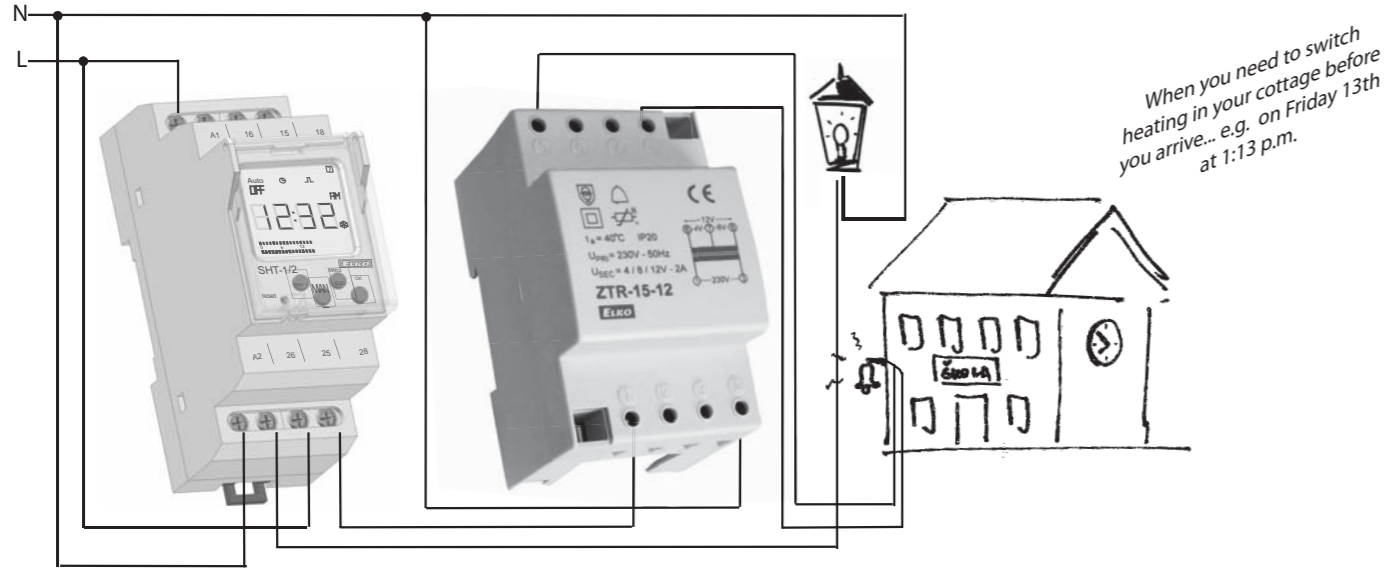

Programmable digital relay PDR-2

- illumination, ventilators, contactors controlling, controlling of interlocking plans, system of time abate and blocking (billiards, pin-balls...), away control via external buttons

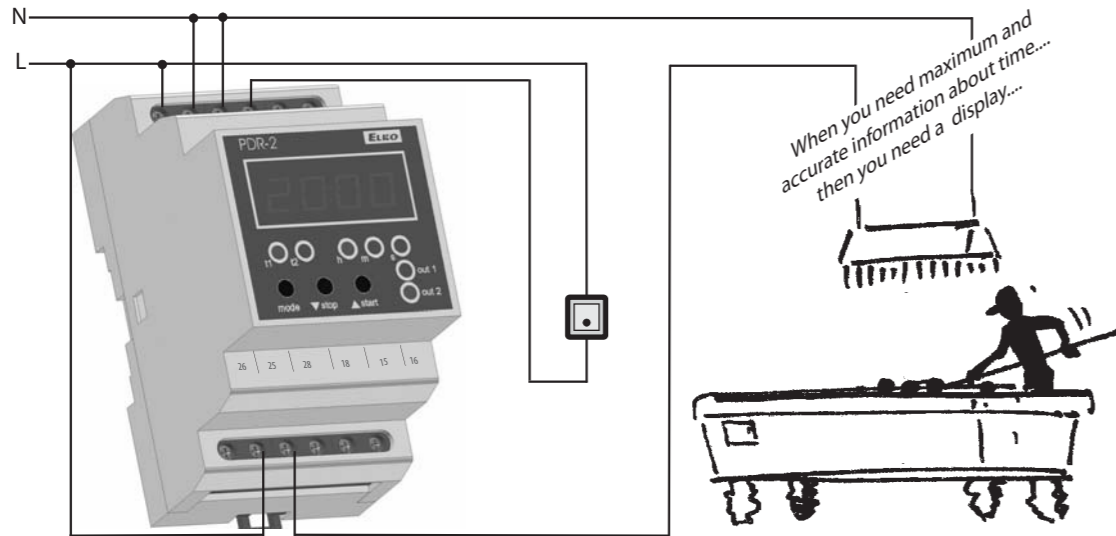

Twilight switch SOU-1

- outdoor illumination switching (garden illumination), flash, shop-window, hall and office illumination (switch off in desired light level, controlling of intensity)

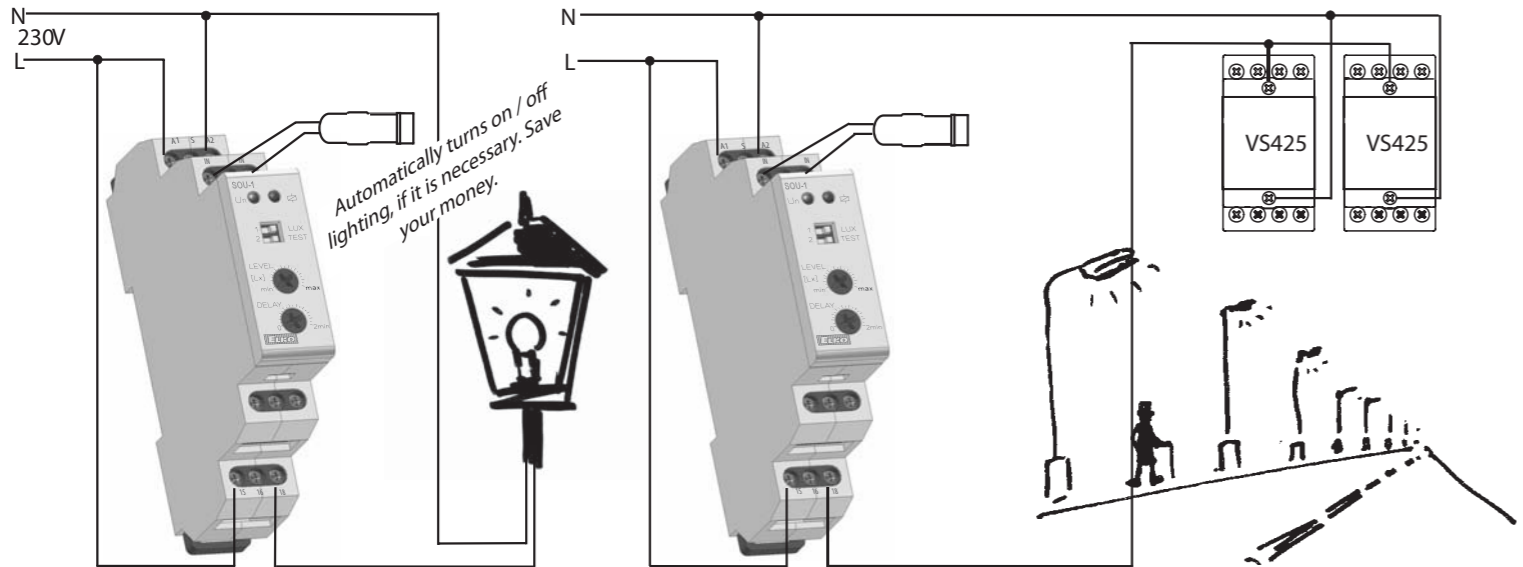

Delay on star/delta CRM-2T

- motor starting more than 3 kW, electronic switchover from mode start to mode operation with device CRM-2T, what assures exact timing

Mini contactor VS425

- switching of the higher loads, especially in other categories than AC1

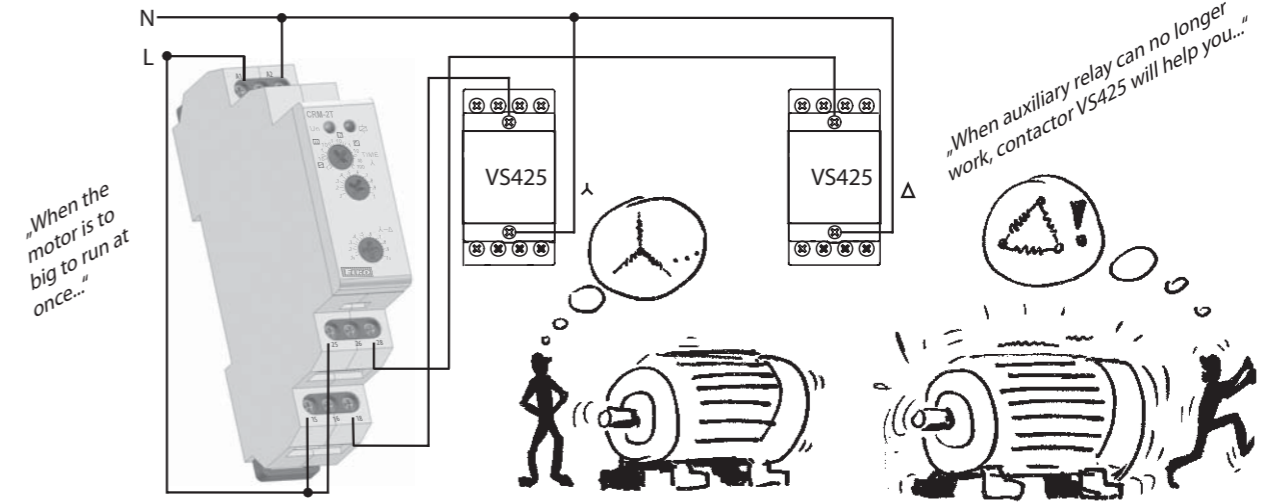

Modular contactor VS120, VS220, VS420, VS425

- to switch circuits for supply and control of heating, lights, air-conditioning and other el. devices.
- Switches loads AC-1, AC-3, AC-7a, AC-7b, AC-15.

Modular contactors VS440, VS463

- to switch supply and control circuits for heating, air-conditioning and other el. devices, switching 3-phase motors
- Switches loads A-1, AC-3, AC-7a, AC-7b, and AC-15

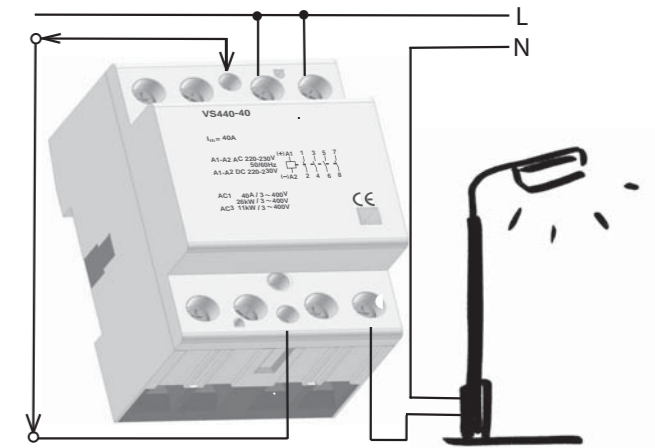
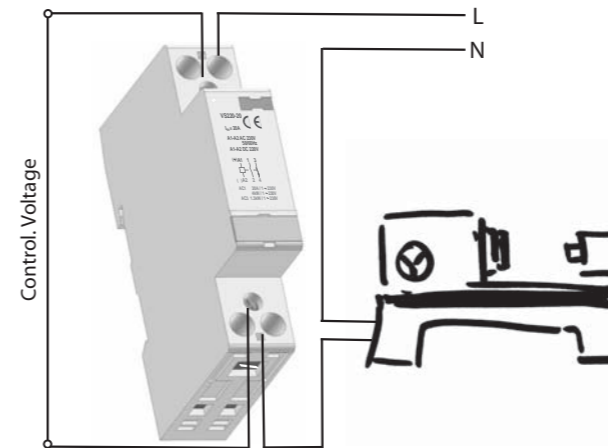

Auxiliary plug-in relays 750L, 782L

- to switch bigger output (load)

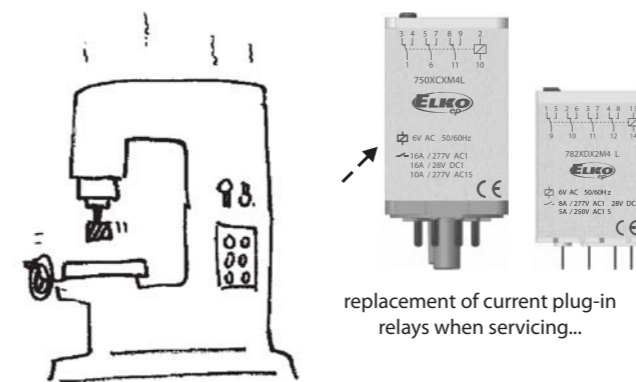

Digital time switch SHT-1, SHT-1/2

- for controlling of all appliances that depend on real time, in daily or weekly mode

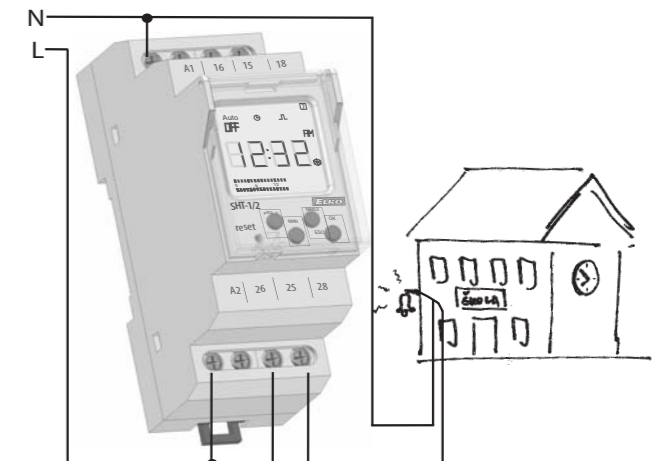

Staircase automat with dimming DIM-2

- step by step (fluent) dim up, adjusted time is ON and fluent dim down (e.g. possible to adjust permanent shine to min. brightness everlasting light)
- block of flats (entry, halls, staircases), garden lighting

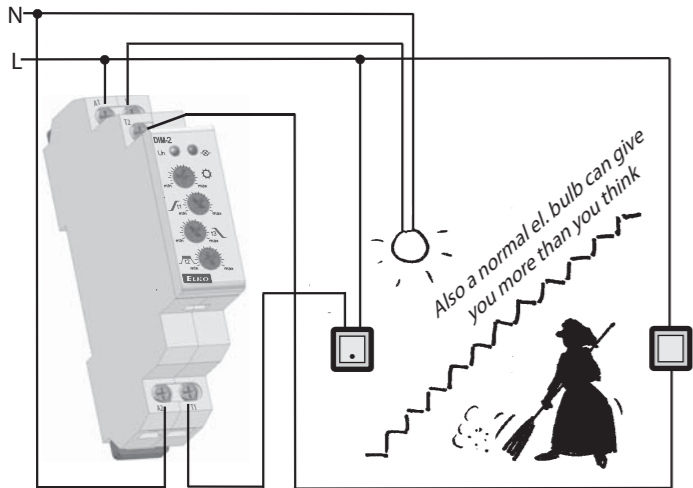

Memory relay MR-41, MR-42

- because of 2-wire parallel buttons connection save money, place and time during the installation
- light switching, hall, staircase, big rooms, controlling systems, automation

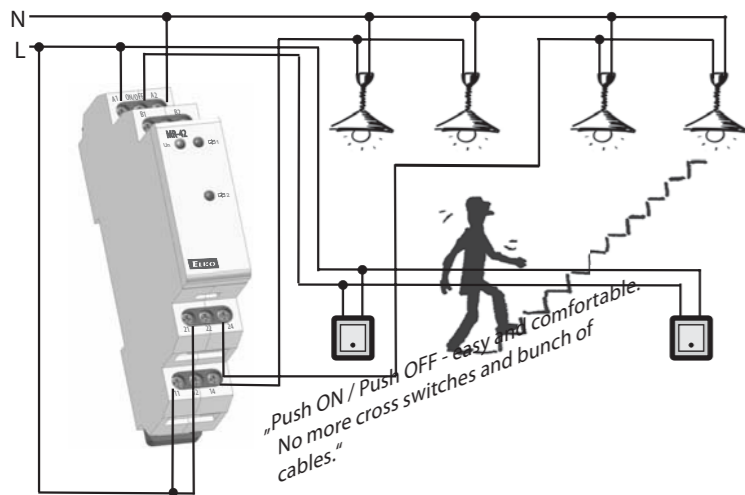

Switching power supply PS-R

- power supply of any devices and appliances via safe voltage with full galvanically separated from mains
- power supply of driving systems, interlocking plants and use in measurement and control

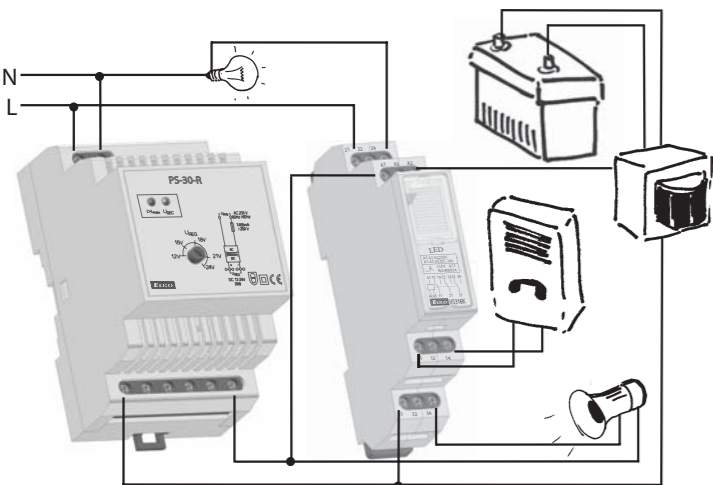

Controlled dimmer DIM-5

- short press ON/OFF, long press - brightness regulation, is in memory. Other presses activate memory
- switch on and dimming of hall, staircase ...

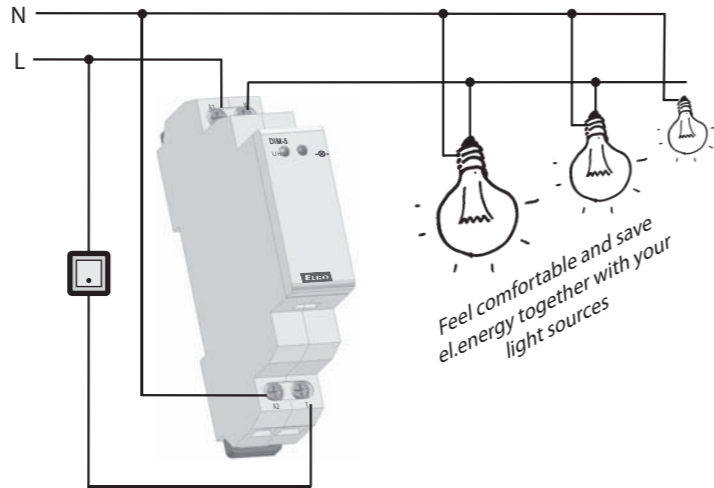

Power relays VS

- switching of higher load than is capacity of switched unit = repeater
- assistant light controlling, signalling, boilers, ...

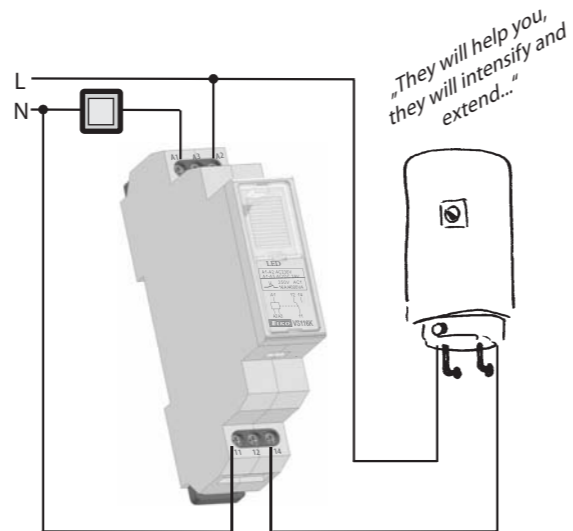

Controlling and signalling units USS

- compact dimensions, elegant design, wide range of use, configuration for request
- switching and signalling in switchboard, controlling centre, automation...

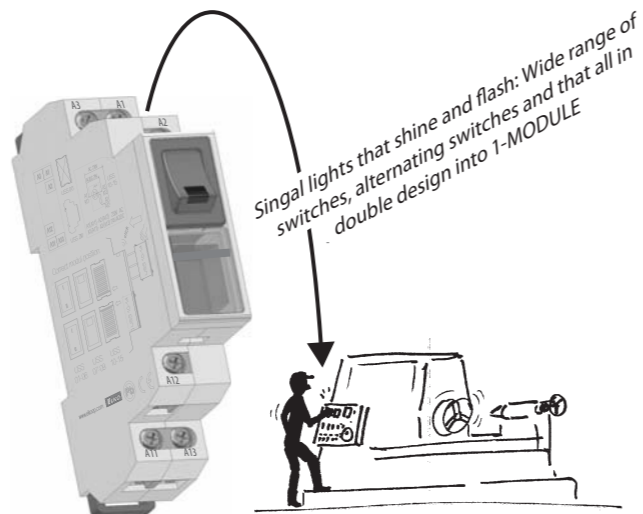

Monitoring voltage relay HRN-33 (35)

- monitoring of mains voltage for appliances inclinable to supply tolerance

Monitoring voltage relay HRN-33 (35)

- protection of appliances against under-/overvoltage

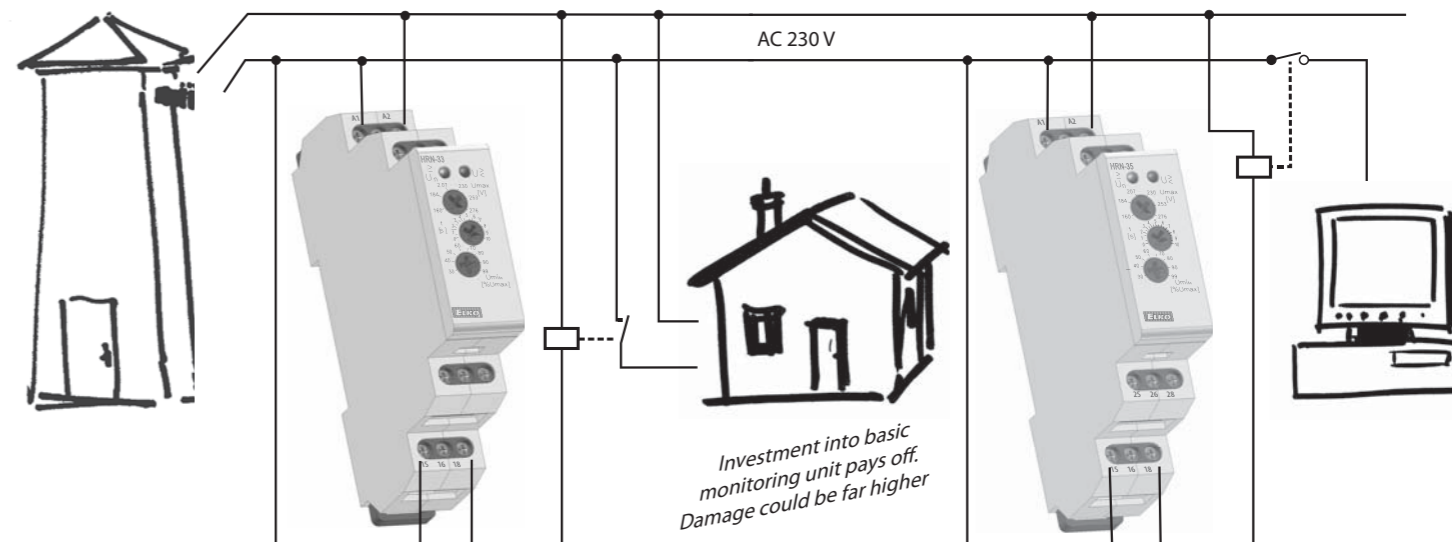

Monitoring voltage relay HRN-35

- start of back-up supply in case of failure

Monitoring voltage relay HRN-34

- load disconnected when voltage declines or battery is discharged

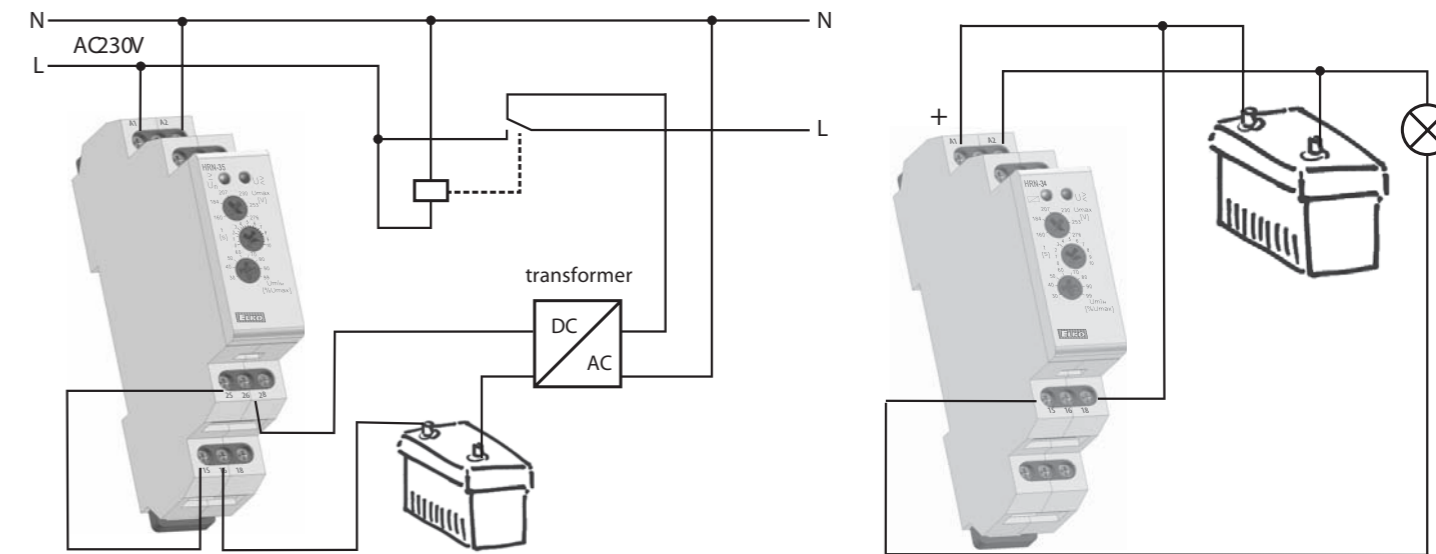

Monitoring current relay PRI-51, PRI-32

- current-limiting relay (on one branch two appliances, which never work together), controlling systems, motors, heating, current indication, controlling of 1-phase motor run down, during the installation of main housing switchboard could be controlled via eye, if the cooker is not switched
- in connection with current transformers, it is possible to extend current ranges up to 600A, which makes more things possible

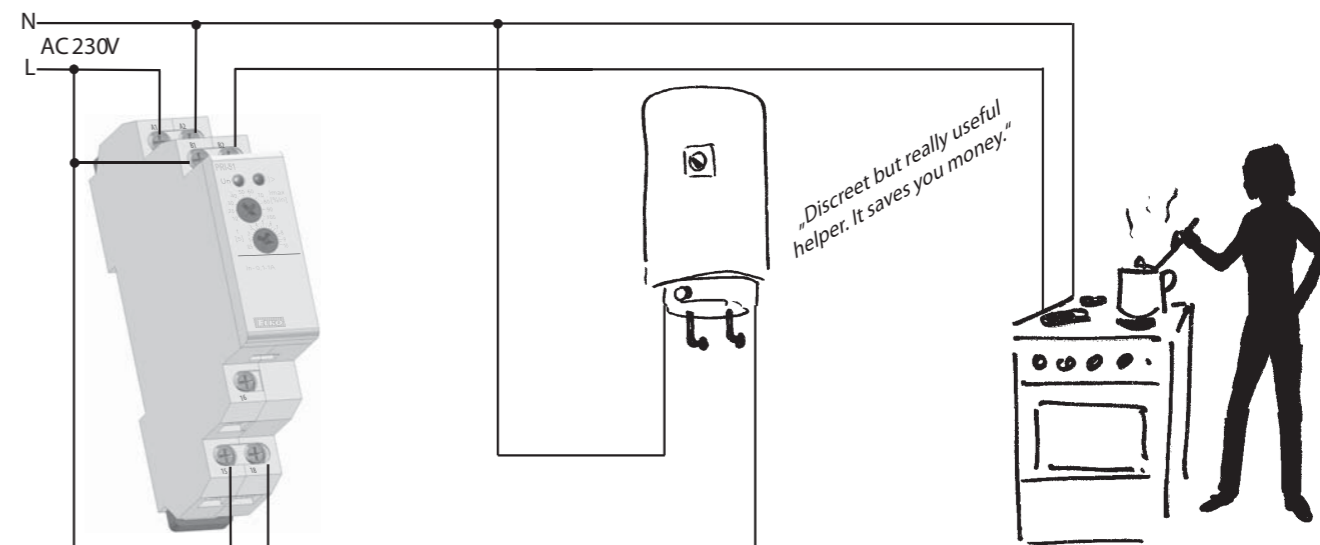

Relay monitoring power factor COS-1

- monitors power-factor in 3-phase mains / unloading of motors, pumps, lift systems

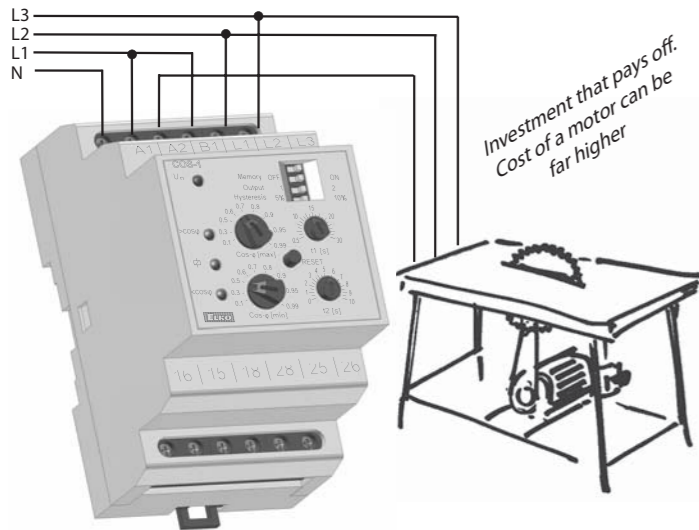

Relay monitoring sequence and failure of phases HRN-55, HRN-55N
- monitoring of proper motor rotation, electric drive, etc.

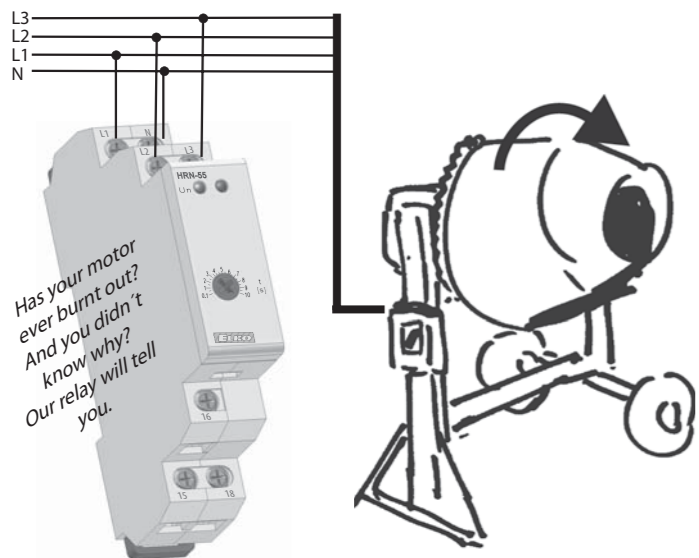

Monitoring voltage relay for under/voltage for 3-phase mains HRN-54
- comfortable monitoring of 3-phase mains

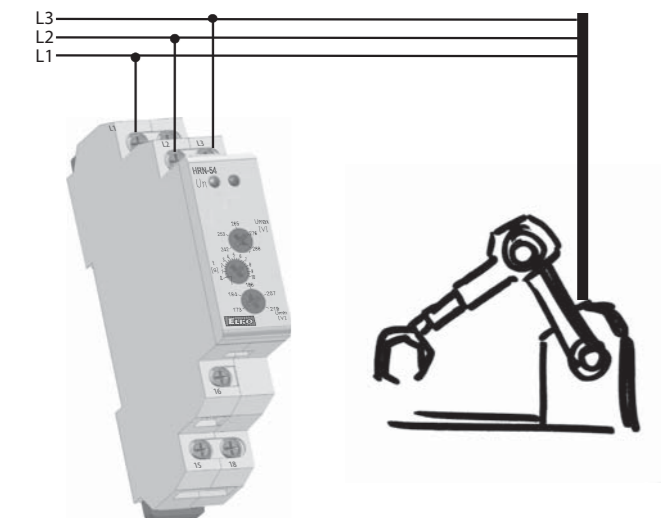

Monitoring voltage relay HRN-43

- regulation of voltage from generator, water el. plants, 3-phase control in the main
- monitors and protects main's quality

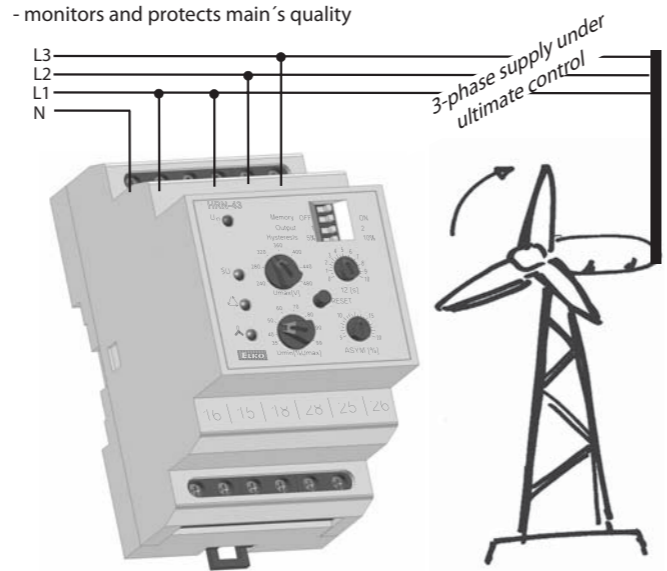

Relay monitoring over-/undervoltage in 3-phase mains HRN-54N
- monitoring voltage in switchboard, protection of appliances

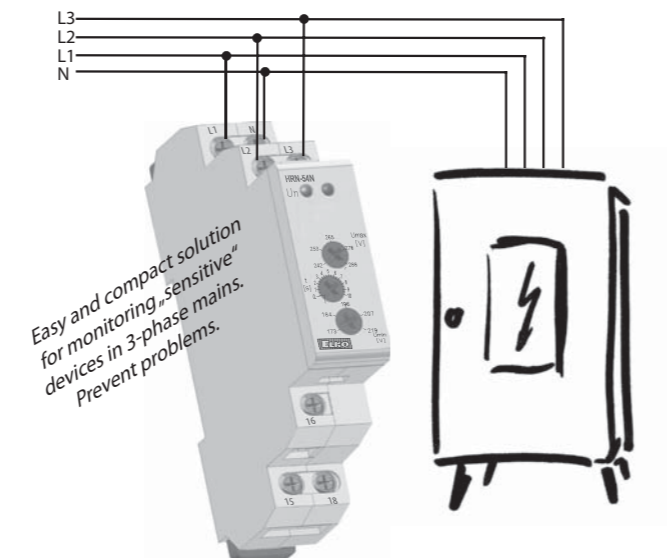

Monitoring current relay PRI-41 (PRI-42)

- monitoring over-/underload (machine, motor ...)
- monitoring consumption, diagnostics of distant appliance (short circuit, increased consump. ...)

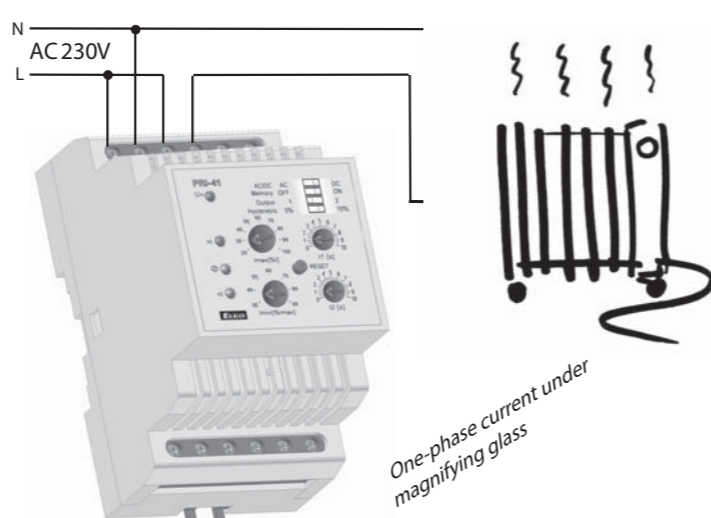

Level switch HRH-1

- monitoring level in wells, tanks, pools, etc.

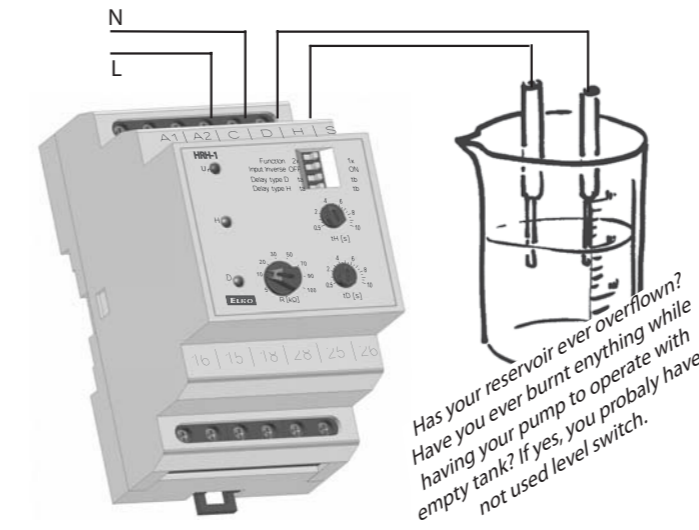

Thermostat TER-3 with external sensor
- control of temperature of floor heating

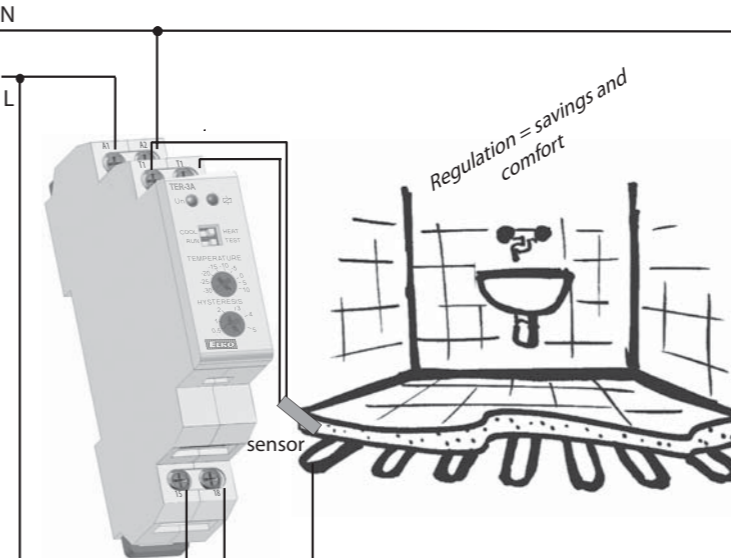

Thermostat for thermal protection of motors TER-7
- protection of motors against thermal overload

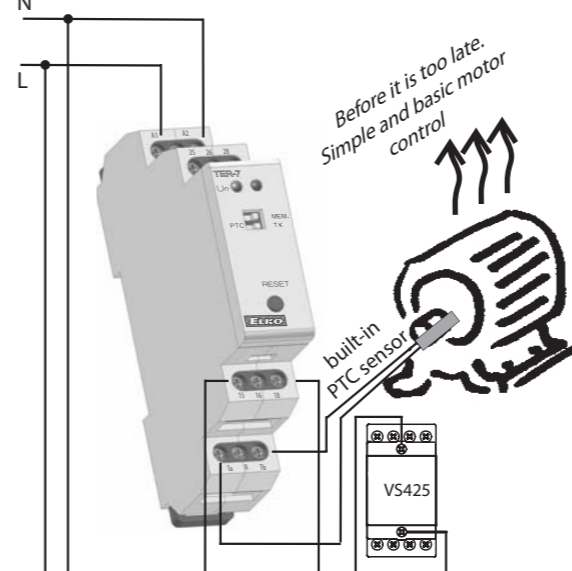

Level switch HRH-5

- monitoring level in well, sump, tanks, pool, silo...

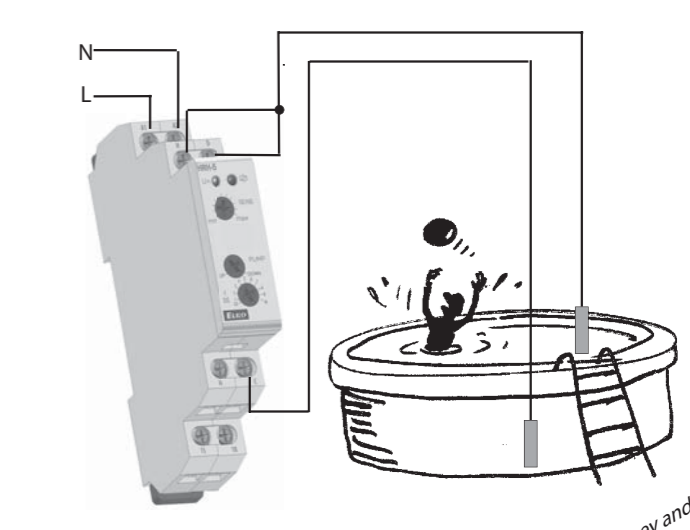

2 stage thermostat TER-4 with 2 external sensors
- control of temperature of e.g. gas/electric boiler

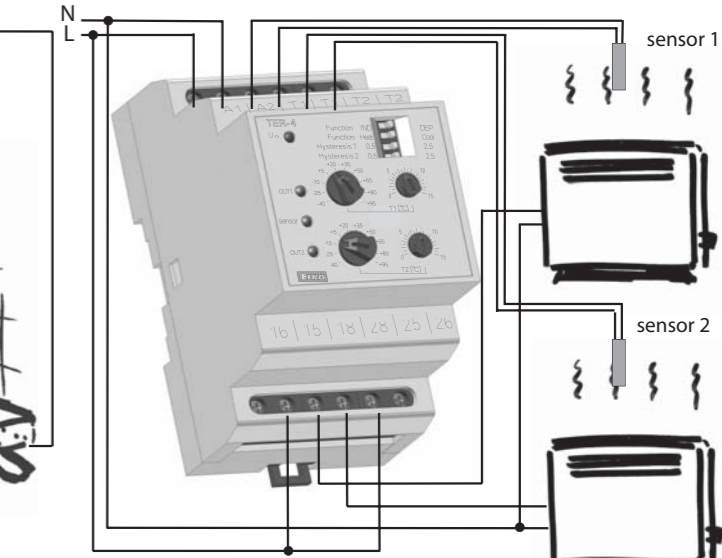

Multifunction digital thermostat TER-9
- complex control of heating and water heating in a house

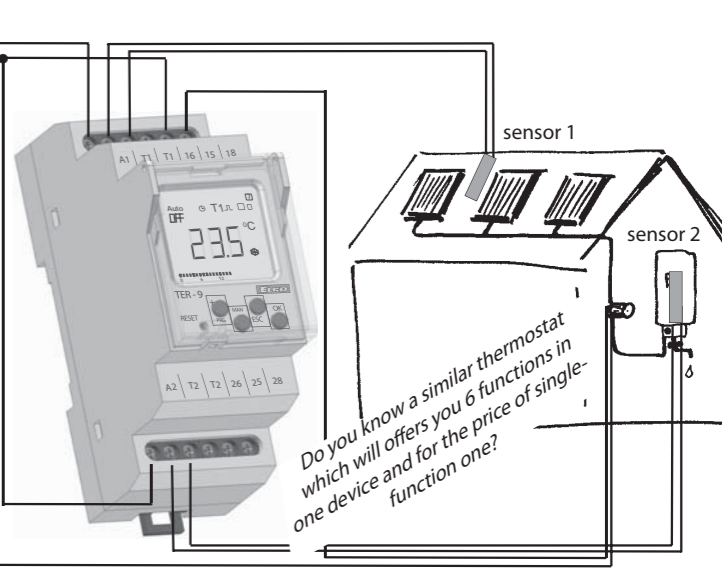

ENJOY THE COMPLETE HOUSEHOLD EQUIPMENT BY ELKO EP

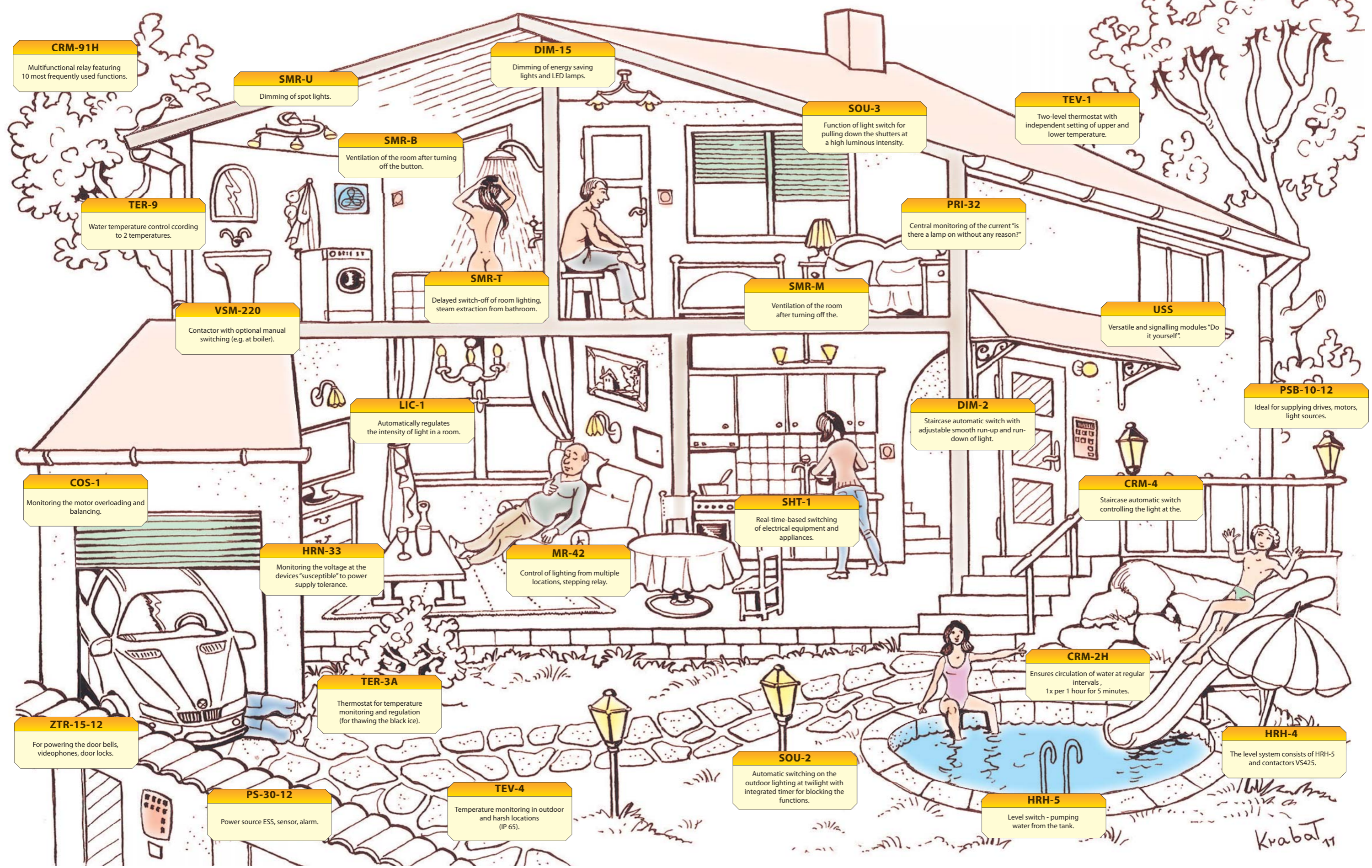

CRM-91H
Multifunctional relay featuring 10 most frequently used functions.

SMR-U
Dimming of spot lights.

DIM-15
Dimming of energy saving lights and LED lamps.

SMR-B
Ventilation of the room after turning off the button.

SOU-3
Function of light switch for pulling down the shutters at a high luminous intensity.

TEV-1
Two-level thermostat with independent setting of upper and lower temperature.

TER-9
Water temperature control according to 2 temperatures.

PRI-32
Central monitoring of the current "is there a lamp on without any reason?"

VSM-220
Contactor with optional manual switching (e.g. at boiler).

SMR-T
Delayed switch-off of room lighting, steam extraction from bathroom.

SMR-M
Ventilation of the room after turning off the.

USS
Versatile and signalling modules "Do it yourself".

LIC-1
Automatically regulates the intensity of light in a room.

DIM-2
Staircase automatic switch with adjustable smooth run-up and run-down of light.

PSB-10-12
Ideal for supplying drives, motors, light sources.

COS-1
Monitoring the motor overloading and balancing.

SHT-1
Real-time-based switching of electrical equipment and appliances.

CRM-4
Staircase automatic switch controlling the light at the.

HRN-33
Monitoring the voltage at the devices "susceptible" to power supply tolerance.

MR-42
Control of lighting from multiple locations, stepping relay.

CRM-2H
Ensures circulation of water at regular intervals, 1x per 1 hour for 5 minutes.

ZTR-15-12
For powering the door bells, videophones, door locks.

TER-3A
Thermostat for temperature monitoring and regulation (for thawing the black ice).

HRH-4
The level system consists of HRH-5 and contactors VS425.

PS-30-12
Power source ESS, sensor, alarm.

TEV-4
Temperature monitoring in outdoor and harsh locations (IP 65).

SOU-2
Automatic switching on the outdoor lighting at twilight with integrated timer for blocking the functions.

HRH-5
Level switch - pumping water from the tank.

KrabaT

INDUSTRIAL USE OF ELKO EP PRODUCTS

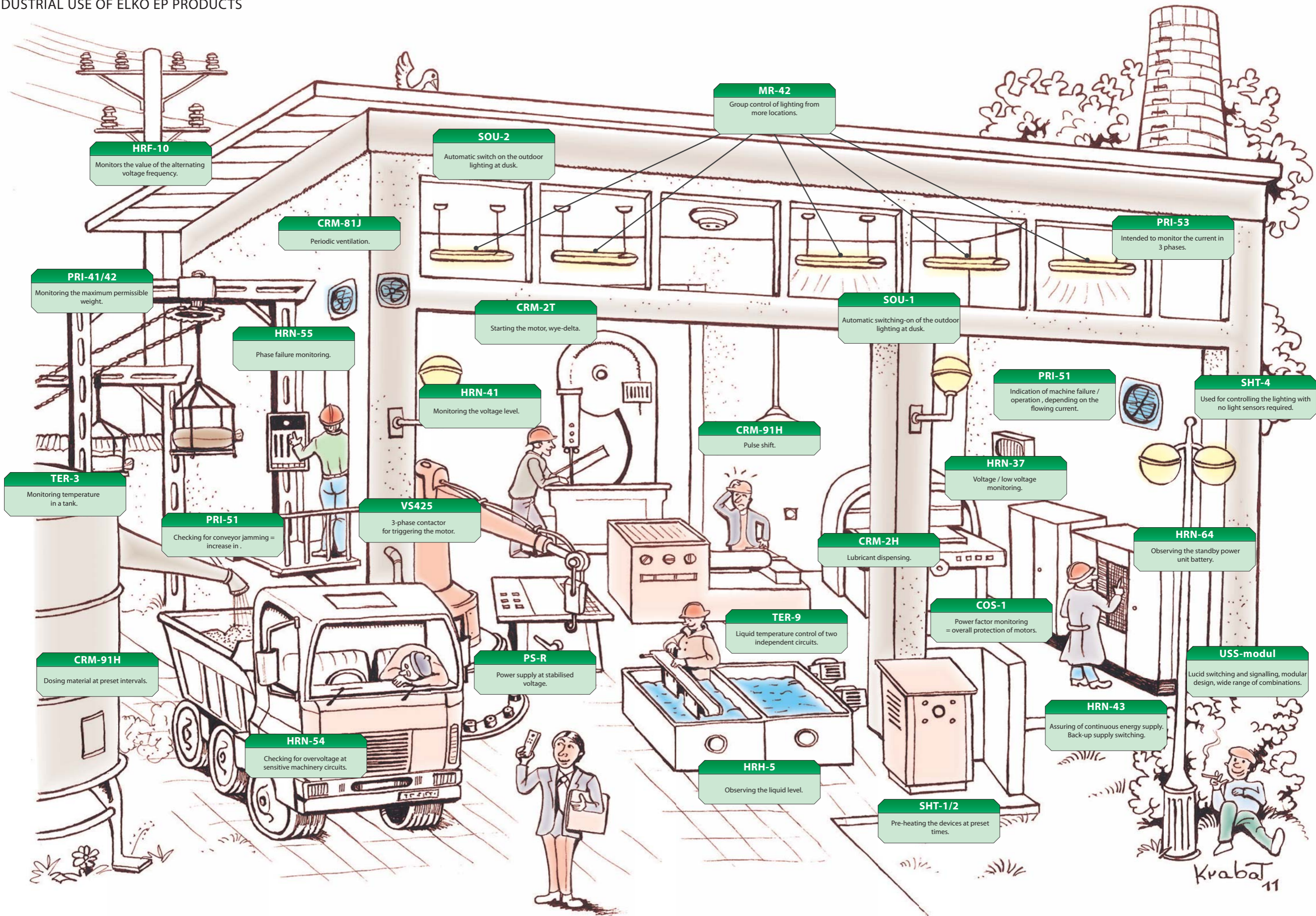

Others just resell

HOWEVER, WE DEVELOP AND MANUFACTURE PRODUCTS OURSELVES!

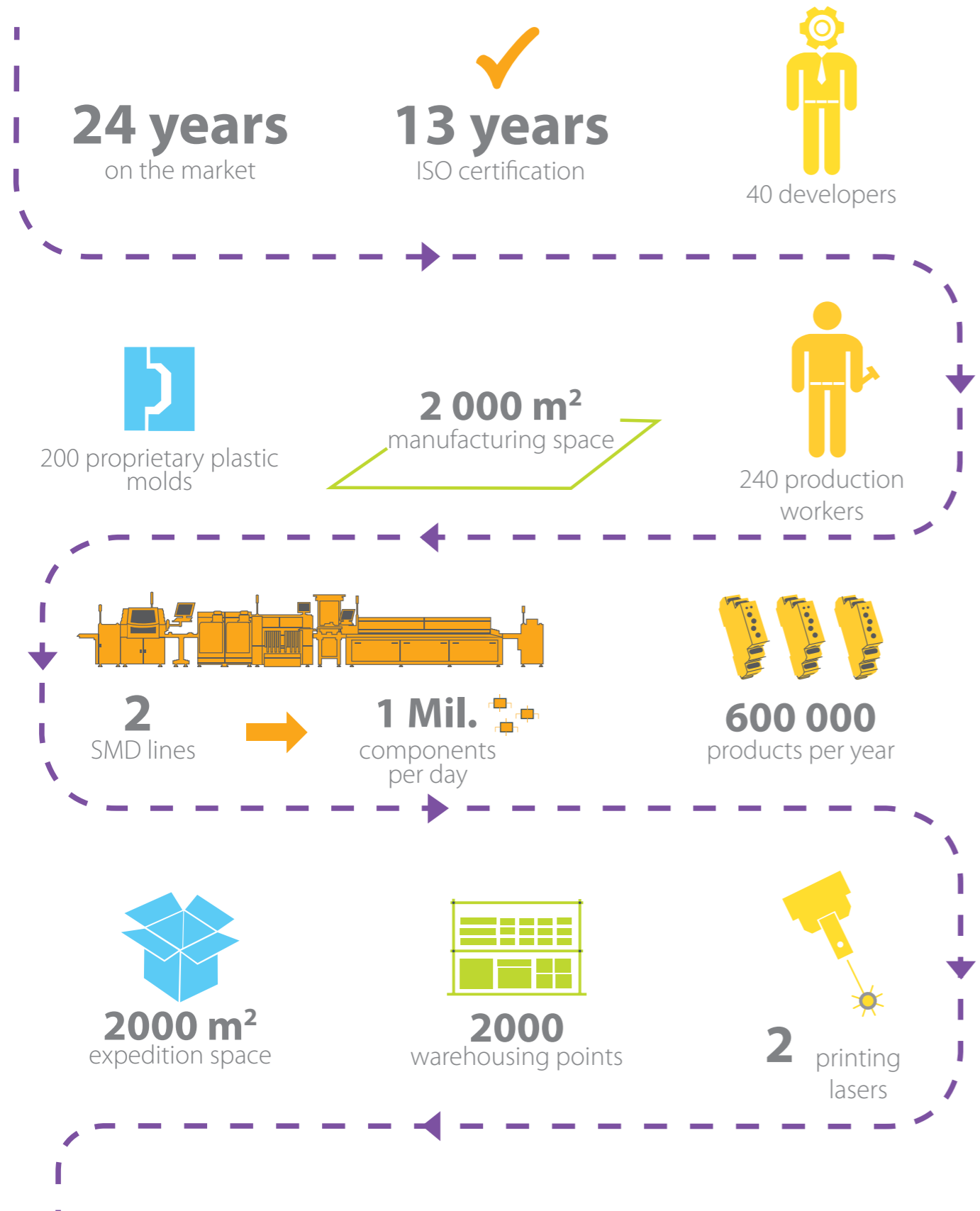

R&D overall view



Internal lab



SMD production line



Chip placing



Production hall



Testing



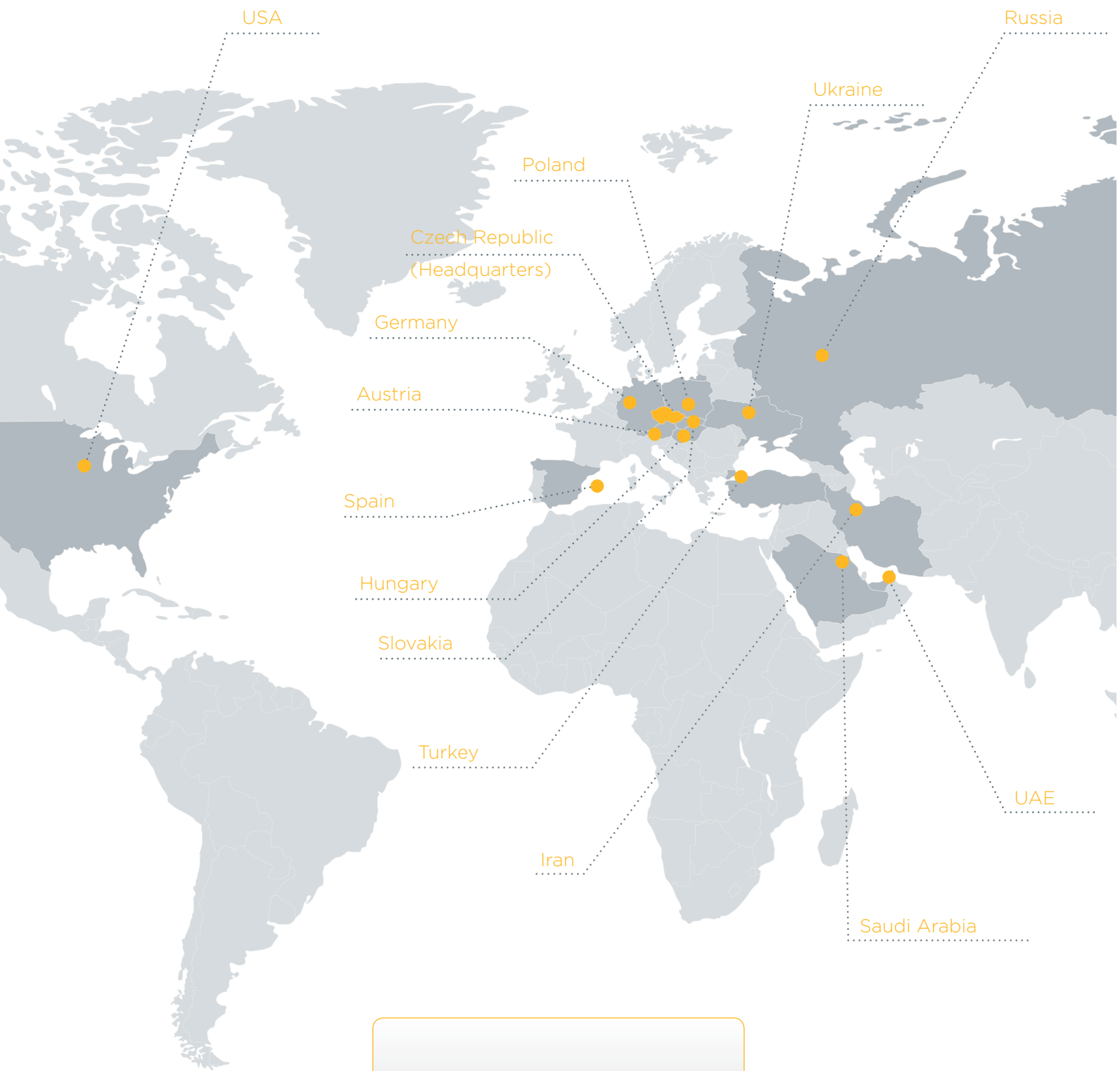

ELKO EP, s.r.o.

Palackeho 493 | 769 01 Holesov, Vsetuly | Czech Republic
phone: +420 573 514 221 | fax: +420 573 514 227 | elko@elkoep.com | www.elkoep.com

Published: 01/2017 | Modifications or amendments reserved | © Copyright ELKO EP, s.r.o. | 1st edition